

5

CLAAS

VARIANT 280 / RC

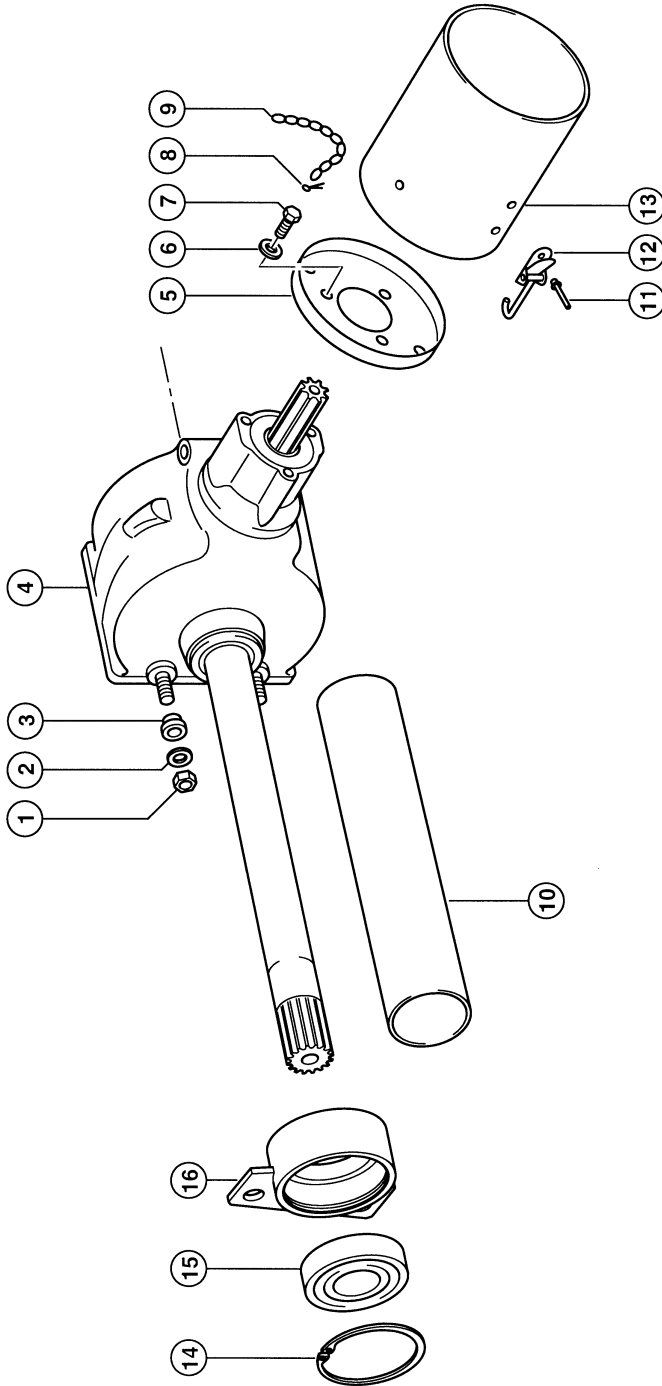

76004z01
VARIANT 280

130325/01

GEARBOX WIT INTERMEDIATE DRIVE ASSY 1)

Pos.	Part No.	Description	Dimension	Quantity	Conditions
1	00 0236 172 0	HEXAGONAL NUT	M12	1	
2	00 0239 389 0	CONTACT WASHER	A12	1	
3	00 0810 117 0	BUSHING	D30X20	1	
4	00 0827 168 1	ANGLE DRIVE	I=5,38	1	2)
4	00 0827 168 0	ANGLE DRIVE		1	3)
5	00 0822 995 1	GUARD CUP		1	
6	00 0239 387 0	CONTACT WASHER	A8-8,2X18X1,4	3	
7	00 0237 439 0	HEXAGON HEAD BOLT	M8X16	3	
8	00 0235 089 0	SPLIT PIN	4 X 22	1	
9	00 0608 099 0	ROUND STEEL CHAIN	G 3X16-17GL	1	
10	00 0821 067 1	PROTECTIVE TUBE	D 110 X 496LG	1	
11	00 0237 950 1	BLIND RIVET	4,8X12	1	
12	00 0822 998 1	LOCK		1	
13	00 0822 996 0	PROTECT.TUBE CPL.		1	
14	00 0243 065 0	CIRCLIP	130X4	1	
15	00 0215 768 0	GRVD.BALL BEARING	6312-2RS*	1	
16	00 0834 187 2	BEARING		1	

1) Remarks P 08 / 20 (1000 U/Min)

2) Remarks from No. 73002217

3) Remarks to No. 73002216

6

CLAAS

VARIANT 280 / RC

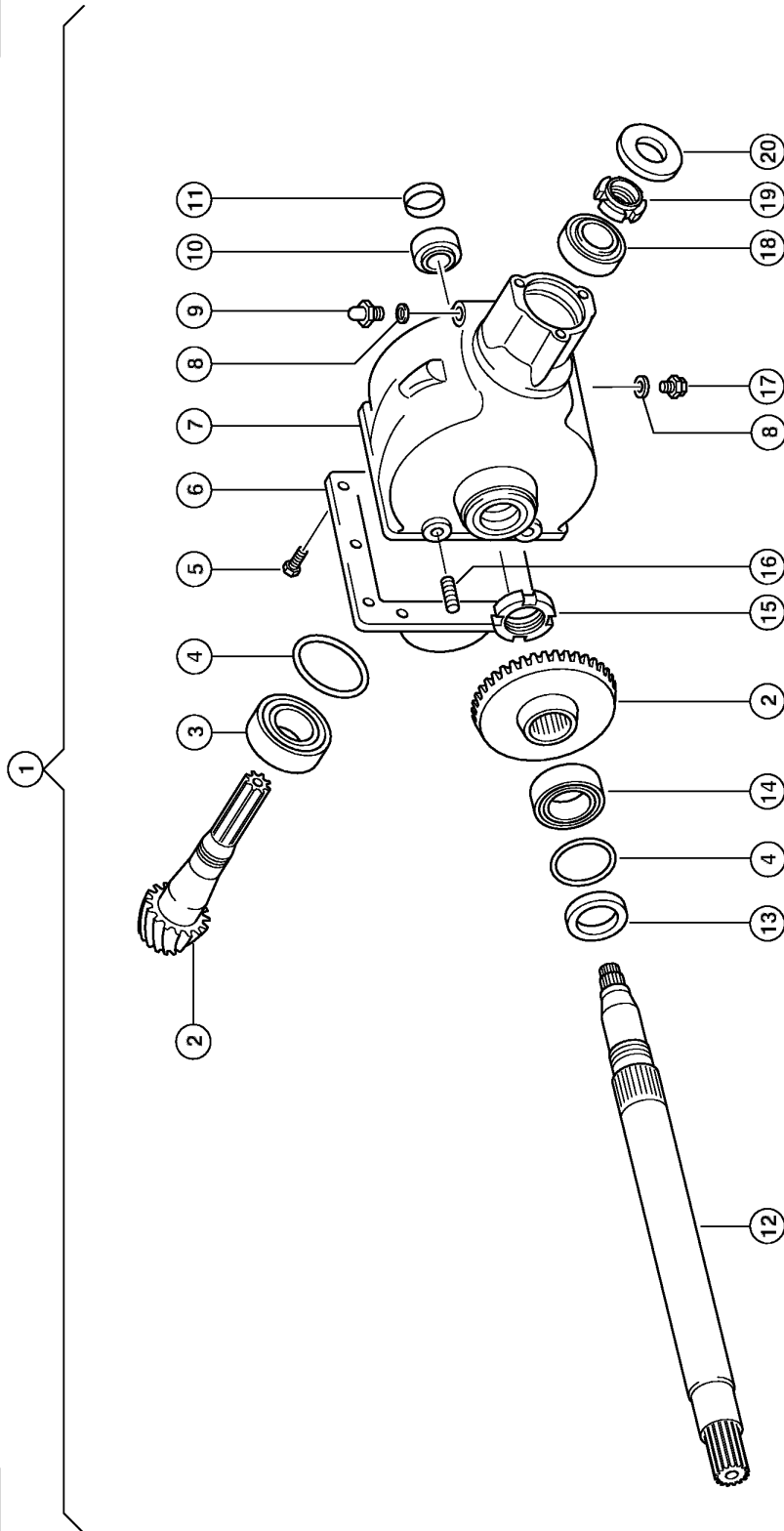

76005z02
VARIANT 280

130326/02

ANGLE DRIVE GEAR BOX 1)

Pos.	Part No.	Description	Dimension	Quantity	Conditions
1	00 0827 168 1	ANGLE DRIVE	I=5,38	1	2)
1	00 0827 168 0	ANGLE DRIVE		1	3)
2	00 0827 578 0	BEVEL GEAR SET		1	
3	00 0243 685 0	TA.ROLLER BEARING	30310 - 50X110X29,25	1	
4	00 0211 966 0	SHIM	100X110X1	2	4)
4	00 0211 965 0	SHIM	100X110X0,5	2	5)
4	00 0211 964 0	SHIM	100X110X0,3	2	6)
4	00 0211 963 0	SHIM	100X110X0,1	4	7)
5	00 0237 442 0	HEXAGON HEAD BOLT	M8X25	12	
6	00 0827 580 0	COVER		1	
7	00 0827 577 1	HOUSING		1	2)
7	00 0843 709 0	HOUSING	WAR 827 577.0	1	3)
8	00 0238 183 0	SEALING RING	A16 X20	4	
9	00 0827 581 0	BREATHER VALVE	1021-04-401-00	1	
10	00 0234 829 0	TA.ROLLER BEARING	30209 J2/Q	1	2)
10	00 0235 988 0	TA.ROLLER BEARING	30208- 40X80X19,75	1	3)
11	00 0213 961 0	SHAFT SEAL	AS 30X 55X10	1	2)
11	00 0211 133 0	SHAFT SEAL	BASL 30X 55X10	1	3)
12	00 0851 341 0	SHAFT		1	2)
12	00 0827 579 0	SHAFT		1	3)
13	00 0211 034 0	ROTARY SHAFT SEAL	AS 60X 85X 8	1	
14	00 0243 661 0	TA.ROLLER BEARING	30212A	1	
15	00 0823 993 0	SLOTTED NUT	M55X1,5	1	
16	00 0244 014 1	STUD BOLT	M12X 45	2	2)
16	00 0213 769 0	STUD BOLT	M12X35	2	3)
17	00 0244 351 0	SCREW PLUG	ERS.D.213769.1 M16X1,5	3	2)
17	00 0090 121 0	SCREW PLUG	M16X1,5	1	3)
18	00 0234 829 0	TA.ROLLER BEARING	30209 J2/Q	1	
19	00 0823 994 0	SLOTTED NUT	M45X1,5	1	
20	00 0213 766 0	SHAFT SEAL	AS 40X 90X12	1	

1)	Remarks	P 08 / 20 (1000 U/Min)
2)	Remarks	from No. 73002217
3)	Remarks	to No. 73002216
4)	Remarks	1.0 mm
5)	Remarks	0.5 mm
6)	Remarks	0.3 mm
7)	Remarks	0.1 mm

7

CLAAS

VARIANT 280 / RC

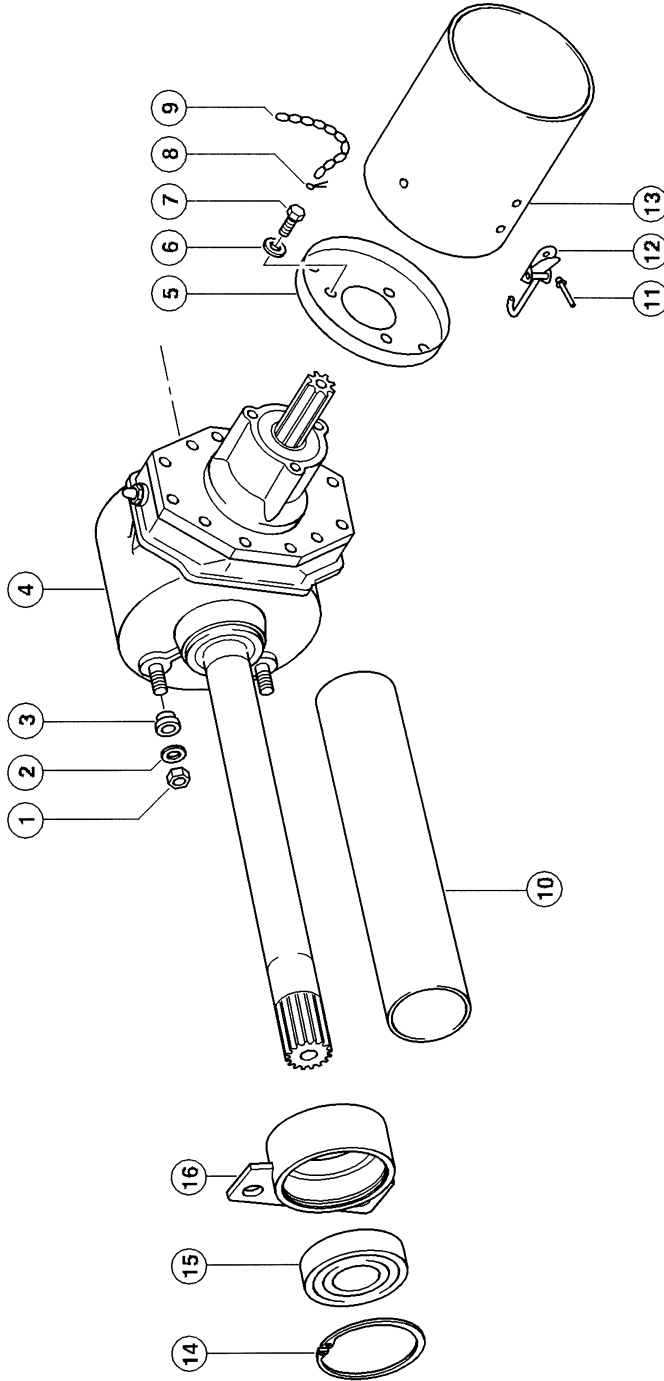

76006z01
VARIANT 280

130327/01

GEARBOX WIT INTERMEDIATE DRIVE ASSY 1)

Pos.	Part No.	Description	Dimension	Quantity	Conditions
1	00 0236 172 0	HEXAGONAL NUT	M12	2	
2	00 0239 389 0	CONTACT WASHER	A12	2	
3	00 0810 117 0	BUSHING	D30X20	2	
4	00 0827 167 2	ANGLE DRIVE	I=2,89	1	2)
4	00 0827 167 1	ANGLE DRIVE	I=2,88	1	3)
4	00 0827 167 0	ANGLE DRIVE		1	4)
5	00 0822 995 1	GUARD CUP		1	
6	00 0239 387 0	CONTACT WASHER	A8-8,2X18X1,4	3	
7	00 0237 439 0	HEXAGON HEAD BOLT	M8X16	3	
8	00 0235 089 0	SPLIT PIN	4 X 22	1	
9	00 0608 099 0	ROUND STEEL CHAIN	G 3X16-17GL	1	
10	00 0821 067 1	PROTECTIVE TUBE	D 110 X 496LG	1	
11	00 0237 950 1	BLIND RIVET	4,8X12	4	
12	00 0822 998 1	LOCK		2	
13	00 0822 996 0	PROTECT.TUBE CPL.		1	5)
14	00 0243 065 0	CIRCLIP	130X4	1	
15	00 0215 768 0	GRVD.BALL BEARING	6312-2RS*	1	
16	00 0834 187 2	BEARING		1	

1) Remarks P 08 / 10 (540 U/Min.)

2) Remarks from no. 73003626

3) Remarks from 73002217-73003625

4) Remarks to No. 73002216

5) Remarks with Item 9, 11, 12

8

CLAAS

VARIANT 280 / RC

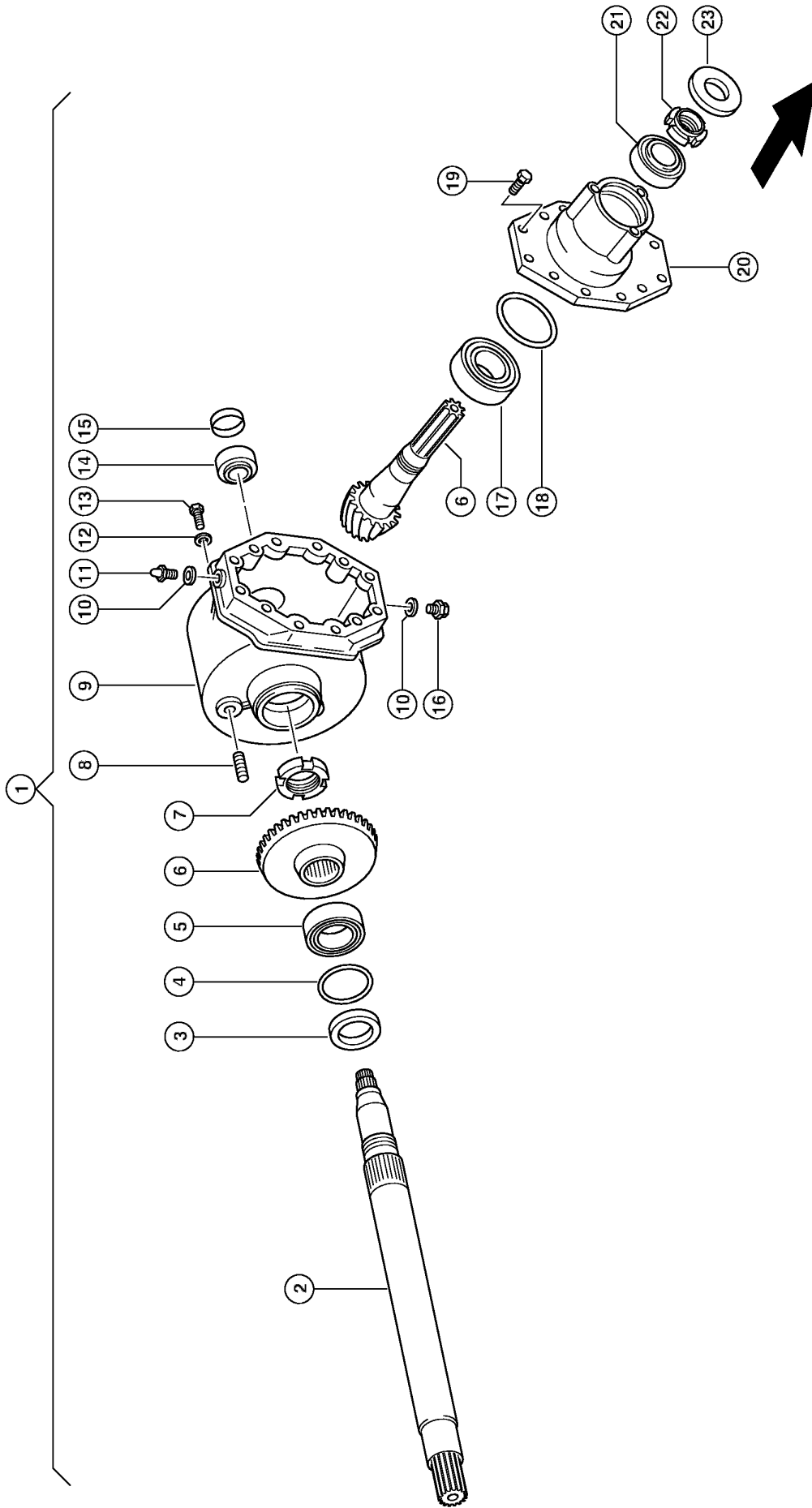

76007z02
VARIANT 280

130328/02

ANGLE DRIVE, 1)

Pos.	Part No.	Description	Dimension	Quantity	Conditions
1	00 0827 167 2	ANGLE DRIVE	I=2,89	1	2)
1	00 0827 167 1	ANGLE DRIVE	I=2,88	1	3)
1	00 0827 167 0	ANGLE DRIVE		1	4)
2	00 0851 341 0	SHAFT		1	5)
2	00 0827 576 0	SHAFT		1	4)
3	00 0211 034 0	ROTARY SHAFT SEAL	AS 60X 85X 8	1	
4	00 0213 765 0	SHIM	85X 95X0,5	1	6)
4	00 0213 764 0	SHIM	85X 95X0,3	1	7)
4	00 0213 962 0	SHIM	85X 95X0,1	1	8)
5	00 0212 210 0	TA.ROLLER BEARING	330 12	1	
6	00 0823 942 0	BEVEL GEAR SET	I=2,88	1	
7	00 0823 993 0	SLOTTED NUT	M55X1,5	1	
8	00 0244 014 1	STUD BOLT	M12X 45	2	2)
8	00 0213 769 0	STUD BOLT	M12X35 ERS.D.213769.1	2	9)
9	00 0844 564 0	HOUSING		1	2)
9	00 0823 941 1	HOUSING		1	3)
9	00 0843 707 0	HOUSING	WAR 823 941.0	1	4)
10	00 0238 183 0	SEALING RING	A16 X20	4	
11	00 0940 866 0	BREATHER VALVE	M 16X1,5 M. SPRITZROHR	1	
12	00 0238 183 0	SEALING RING	A16 X20	2	5)
12	00 0244 842 0	SEALING RING	A10 X14	2	4)
13	00 0244 351 0	SCREW PLUG	M16X1,5	2	5)
13	00 0237 570 0	HEXAGON HEAD BOLT	M10X16	2	4)
14	00 0234 829 0	TA.ROLLER BEARING	30209 J2/Q	1	5)
14	00 0235 986 0	TA.ROLLER BEARING	302 06	1	4)
15	00 0213 961 0	SHAFT SEAL	AS 30X 55X10	1	
16	00 0244 351 0	SCREW PLUG	M16X1,5	1	
17	00 0243 686 0	TA.ROLLER BEARING	30311A - 55X120X31,5	1	5)
17	00 0213 768 0	TA.ROLLER BEARING	313 11	1	4)
18	00 0214 181 0	SHIM	110X120X0,5 ERS.D. 21418	1	5)
18	00 0214 179 0	SHIM	110X120X0,1 ERS.D. 21417	1	5)
18	00 0214 180 0	SHIM	110X120X0,3 ERS.D. 21418	1	5)
18	00 0211 873 0	SHIM	100X119,5X0,2	1	4)
18	00 0239 174 0	SHIM	100X120X0,3	1	4)
18	00 0233 010 0	SHIM	100X120X0,5	1	4)
19	00 0237 572 0	HEXAGON HEAD BOLT	M12X35	8	10)
20	00 0844 565 0	BEARING HOUSING		1	2)
20	00 0823 944 0	BEARING HOUSING		1	9)
21	00 0234 829 0	TA.ROLLER BEARING	30209 J2/Q	1	
22	00 0823 994 0	SLOTTED NUT	M45X1,5	1	
23	00 0213 766 0	SHAFT SEAL	AS 40X 90X12	1	
23	00 0836 429 0	SHAFT GUARD	EP 190/W24	1	

1)	Remarks	P 08 / 10 (540 U/Min.)
2)	Remarks	from no. 73003626
3)	Remarks	from 73002217-73003625
4)	Remarks	to No. 73002216
5)	Remarks	from No. 73002217
6)	Remarks	0.5 mm

ANGLE DRIVE, 1)

7) Remarks	0.3 mm
8) Remarks	0.1 mm
9) Remarks	up to no. 73003625
10) Remarks	(12)

CLAAS

1

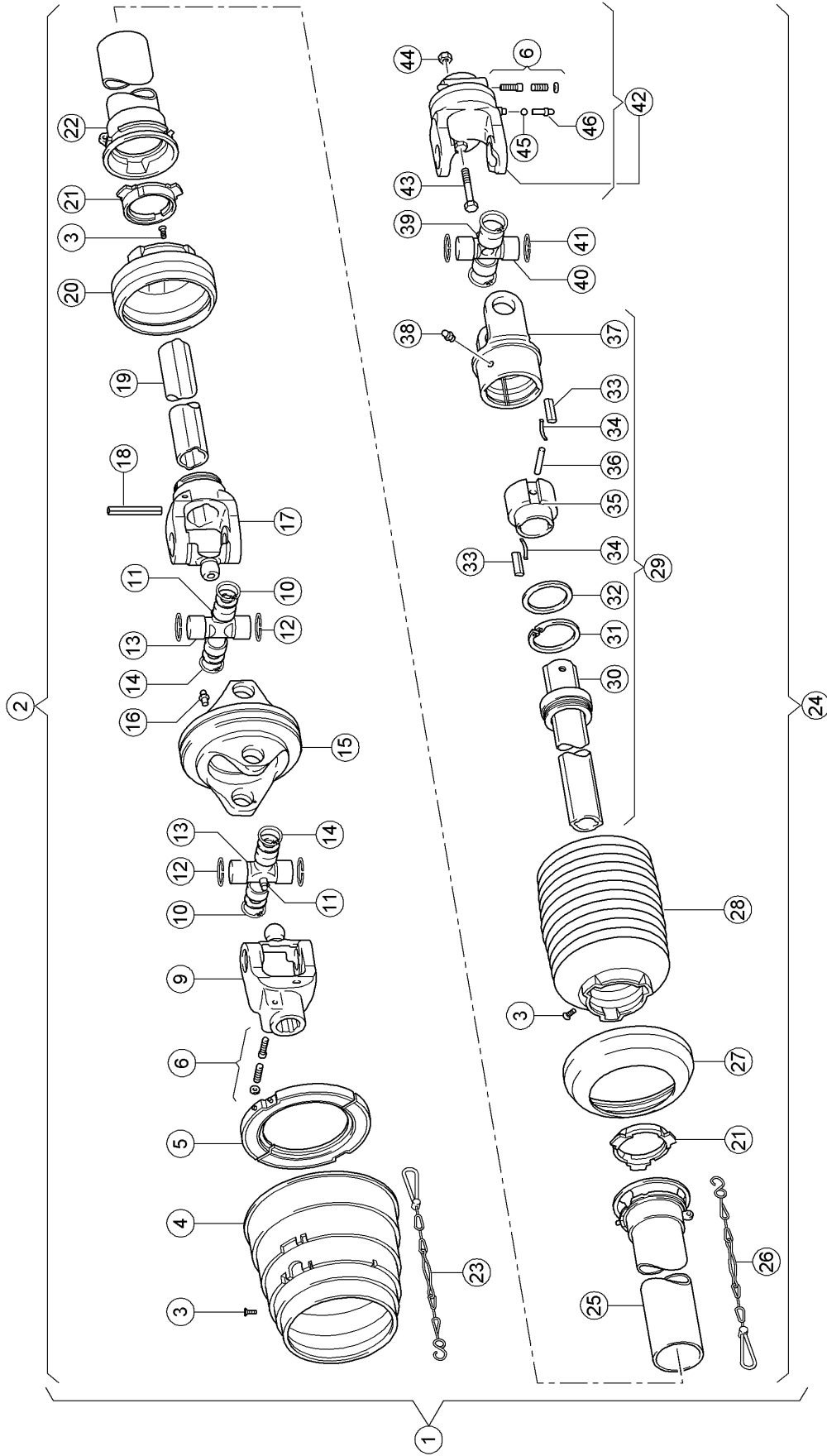

76000z02
VARIANT 280

130320/02

UNIVERSAL DRIVE SHAFT WITH SHEAR BOLT CL 1)

Pos.	Part No.	Description	Dimension	Quantity	Conditions
1	00 0822 960 1	DRIVE SHAFT ASSY.		1	2)
1	00 0827 730 0	DRIVE SHAFT ASSY.		1	3)
2	00 0822 961 0	DRIVE SHAFT HALF		1	4)
2	00 0822 966 0	DRIVE SHAFT HALF		1	5)
3	00 0242 793 0	CYCL. PLATE SCREW	C4,2X 9,5	8	
4	00 0821 097 0	PROTECT.FUNNEL		1	
5	00 0821 098 0	GLIDE RING		1	
6	00 0941 062 0	SLIDING PIN SET		2	
9	00 0941 475 0	EXTENSION FORKE		1	2)
9	00 0834 032 0	CLAMPING CONE	CC 1 3/8"	1	3)
10	00 0972 503 0	CIRCLIP		4	
11	00 0244 946 0	GREASE NIPPLE	B M8X1	2	
12	00 0242 908 0	CIRCLIP	32X1,2	4	
13	00 0820 421 0	CENTRE CROSS ASS.		2	
14	00 0921 267 0	WASHER		4	
15	00 0921 268 0	DOUBLE FORK		1	
16	00 0179 838 0	GREASE NIPPLE	A M8X1	1	
17	00 0941 486 0	FORK		1	
18	00 0244 581 2	SPRING PIN	10X 80	1	
19	00 0838 042 0	PROFILE TUBE		1	6)
20	00 0821 103 0	PROTECT.FUNNEL		1	
21	00 0920 671 0	GLIDE RING		2	
22	00 0824 446 0	PROTECTIVE TUBE		1	7)
23	00 0821 104 0	SUPPORTING CHAIN		1	
24	00 0827 051 0	DRIVE SHAFT HALF		1	8)
25	00 0823 180 0	GUARD HALF		1	7)
26	00 0972 297 0	SUPPORTING CHAIN		1	
27	00 0917 283 0	BACK-UP RING		1	
28	00 0813 018 1	PROTECT.FUNNEL		1	
29	00 0824 457 0	KEYOVERRUN CLUTCH		1	9)
30	00 0824 458 0	PROFILE TUBE		1	
31	00 0235 186 0	CIRCLIP	72X2,5	1	
32	00 0234 388 0	BACK-UP WASHER	S 56X 72	1	
33	00 0814 228 0	STOP KEY		2	
34	00 0814 229 0	FLAT SPRING		2	
35	00 0813 015 0	HUB		1	
36	00 0213 698 1	SPRING PIN	10 X 55 N-ST	1	
37	00 0823 186 0	CLUTCH HOUSING		1	2)
37	00 0824 477 0	CLUTCH HOUSING		1	3)
38	00 0179 838 0	GREASE NIPPLE	A M8X1	1	
39	00 0244 946 0	GREASE NIPPLE	B M8X1	1	
40	00 0941 651 0	CENTRE CROSS ASS.		1	
41	00 0242 908 0	CIRCLIP	32X1,2	4	
42	00 0827 077 0	SHEAR BOLT CLUTCH		1	10)
43	00 0235 521 0	HEXAGON HEAD BOLT	M8-60	1	
43	00 0233 406 0	HEXAGON HEAD BOLT	M 8X65	1	11)
44	00 0238 132 0	LOCK NUT	M8	1	
45	00 0238 635 0	STEEL BALL	7,938 G28	24	
46	00 0941 090 0	GREASE NIPPLE		1	

1) Remarks

Walterscheid
m 04 / 10 = 6tlg Anschluss
m 04 / 20 = 8tlg Anschluss

2) Remarks

6-pitch connection

UNIVERSAL DRIVE SHAFT WITH SHEAR BOLT CL 1)

3) Remarks	8-pitch connection
4) Remarks	tractor side 6-pitch connection
5) Remarks	tractor side 8-pitch connection
6) Remarks	1045 long
7) Remarks	1000 long
8) Remarks	machine side
9) Remarks	with Item 30 - 37
10) Remarks	with Item 6 - 8, 43 - 46
11) Remarks	alternative

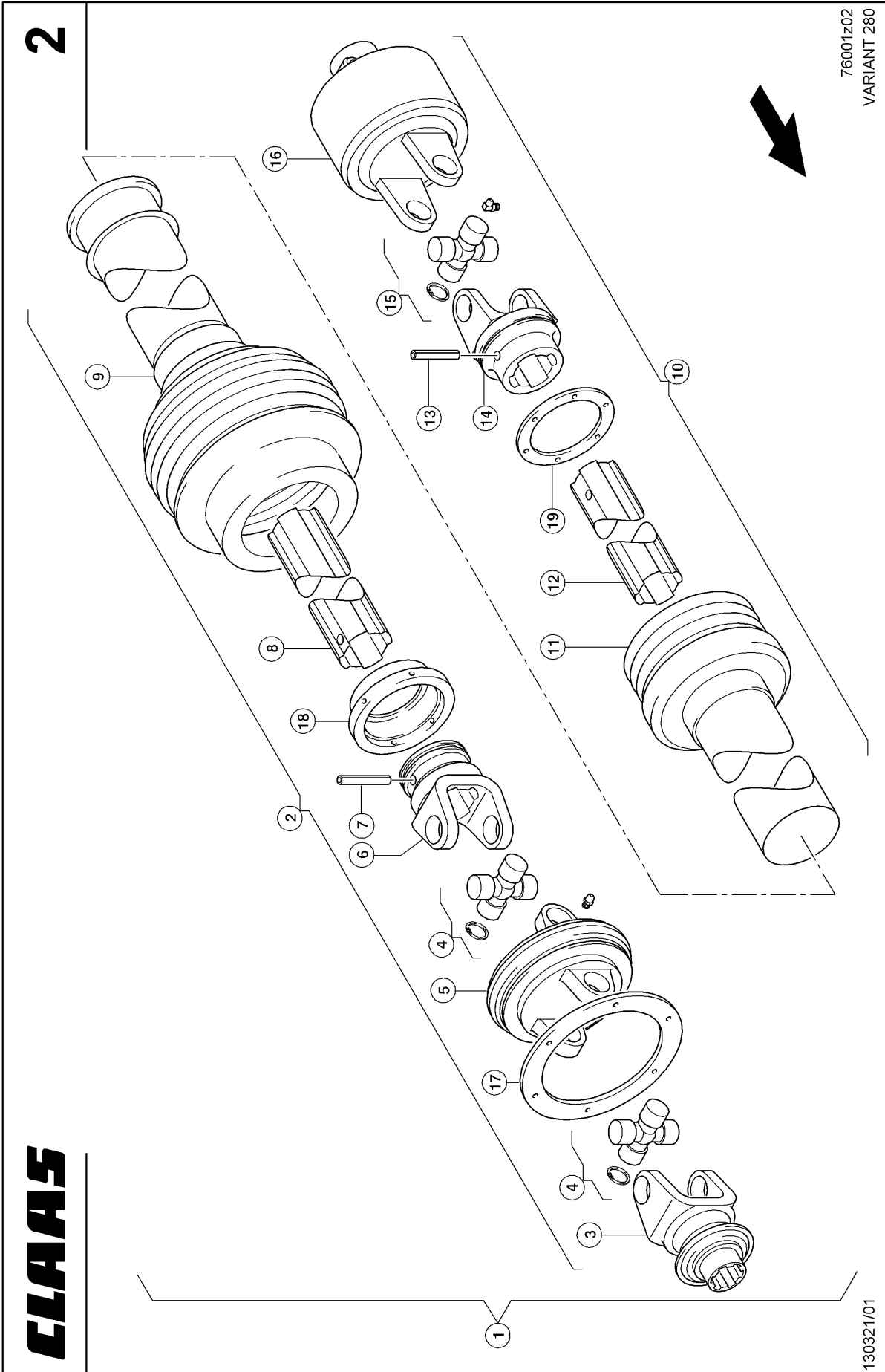

UNIVERSAL DRIVE SHAFT WITH CUT - OUT CLU 1)

Pos.	Part No.	Description	Dimension	Quantity	Conditions
1	00 0834 831 0	DRIVE SHAFT		1	
2	00 0834 835 0	DRIVE SHAFT HALF		1	
3	00 0836 402 0	FORK		1	2)
3	00 0836 403 0	FORK		1	3)
4	00 0836 404 0	CENTRE CROSS ASS.		2	
5	00 0836 406 0	FORK		1	
6	00 0836 405 0	INNER FORK		1	4)
6	00 0843 292 0	INNER FORK		1	5)
7	00 0244 580 0	SPRING PIN	10 X 75	1	
8	00 0836 407 0	PROFILE TUBE		1	4)
8	00 0843 290 0	PROFILE TUBE	2250X1067	1	5)
9	00 0836 400 0	GUARD HALF		1	
10	00 0834 837 0	DRIVE SHAFT HALF		1	
11	00 0836 401 1	GUARD HALF		1	
12	00 0836 408 0	PROFILE TUBE		1	4)
12	00 0843 291 0	PROFILE TUBE	2451X1075	1	5)
13	00 0237 614 2	SPRING PIN	10X 70 -ST	1	
14	00 0836 409 0	INNER FORK		1	4)
14	00 0843 293 0	FORK		1	5)
15	00 0836 410 0	CENTRE CROSS ASS.		1	
16	00 0836 412 0	CLUTCH		1	6)
17	00 0836 344 0	RING		1	
18	00 0836 347 0	RING		1	
19	00 0836 346 0	RING		1	

1)	Remarks	m 04 / 30 = 6-Tlg Anschluss Bondioli
2)	Remarks	6 piece
3)	Remarks	21 piece
4)	Remarks	from No. 73001545
5)	Remarks	to No. 73001544
6)	Remarks	see illustration plate 4

2A

CLAAS

BGZ 09010

76145Z00
VARIANT 280

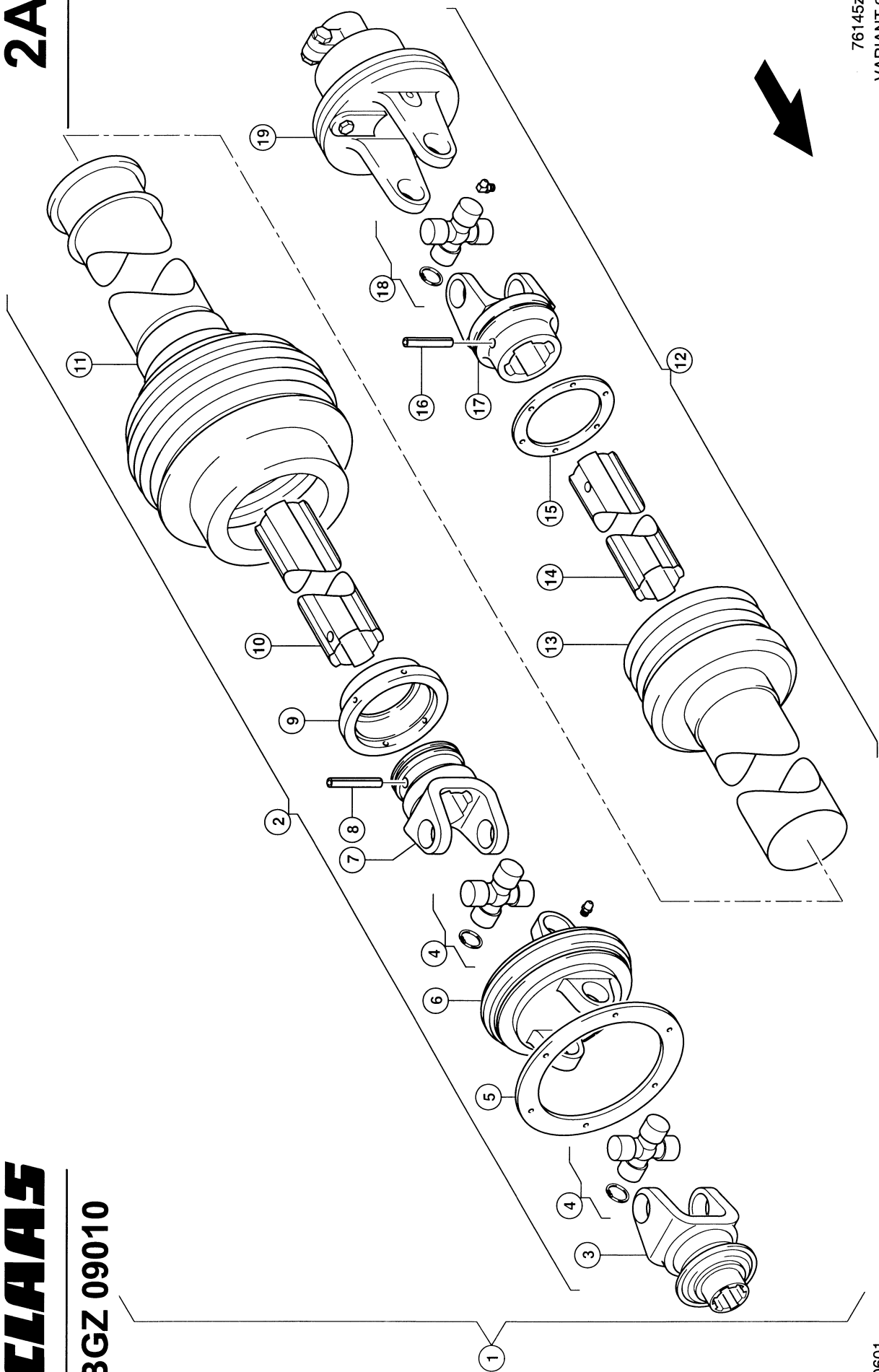

130601

Thank you so much for reading.
Please click the “Buy Now!”
button below to download the
complete manual.



After you pay.

You can download the most
perfect and complete manual in
the world immediately.

Our support email:

ebooklibonline@outlook.com