

500 MAIN GEARBOX 1)

Pos.	Part No.	Description	Dimension	Quantity	Conditions
1	00 0236 172 0	HEXAGONAL NUT	M12	1	
2	00 0239 389 0	CONTACT WASHER	A12	1	
3	00 0810 117 0	BUSHING	D30X20	1	
4	00 0843 463 0	GUARD CUP	D206X1.5	1	
5	00 0239 387 0	CONTACT WASHER	A8-8,2X18X1,4	3	
6	00 0237 439 0	HEXAGON HEAD BOLT	M8X16	3	
7	00 0235 089 0	SPLIT PIN	4 X 22	1	2)
8	00 0608 099 0	ROUND STEEL CHAIN	G 3X16-17GL	1	2)
9	00 0233 918 0	HEXAGON HEAD BOLT	M 5X16	1	2)
9	00 0236 910 2	FLAT WASHER	5 -5,3X10X1	1	2)
9	00 0237 216 0	HEXAGONAL NUT	M05	1	2)
10	00 0868 298 0	PROTECTIVE TUBE	D 110 X 488LG	1	3)
10	00 0821 067 2	PROTECTIVE TUBE	D 110 X 493LG	1	4)
11	00 0237 922 1	BLIND RIVET	A 4X12	4	
12	00 0822 998 1	LOCK		2	
13	00 0822 996 0	PROTECT.TUBE CPL.		1	
14	00 0243 065 0	CIRCLIP	130X4	1	
15	00 0215 768 0	GRVD.BALL BEARING	6312-2RS*	1	
16	00 0843 465 0	BEARING		1	
17	00 0836 261 1	PIN	D25X48	1	
18	00 0234 238 0	WASHER	26X42X1	1	
19	00 0237 033 0	SPLIT PIN	6,3X 40	1	

1) Equipment

PR_P08_0020

Input gearbox 1,000 rpm

2) machine no.

+ up to 77100484

3) machine no.

+ from 77100965

4) machine no.

+ up to 77100964

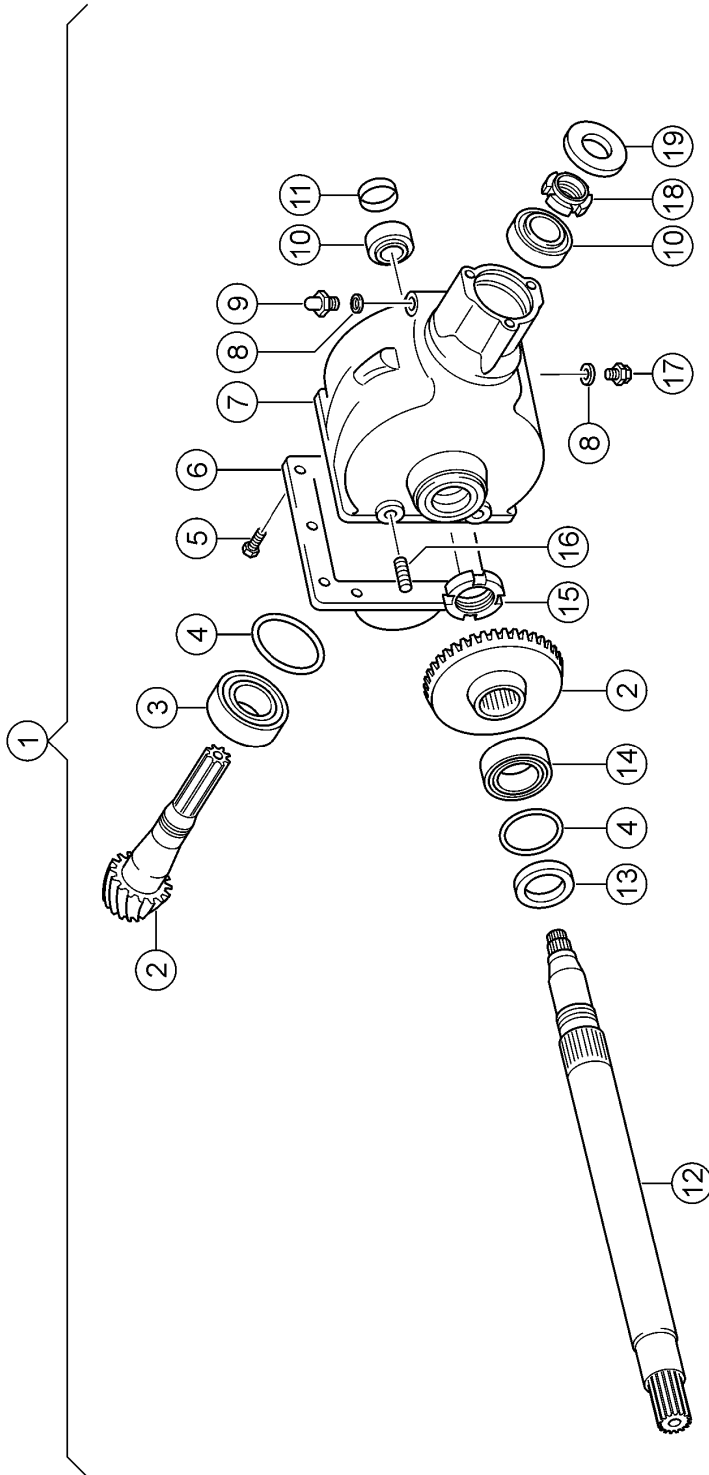

500 MAIN GEARBOX 1)

Pos.	Part No.	Description	Dimension	Quantity	Conditions
1	00 0844 729 0	GEARBOX	I=5,38	1	
2	00 0827 578 0	BEVEL GEAR SET		1	
3	00 0243 685 0	TA.ROLLER BEARING	30310 - 50X110X29,25	1	
4	00 0211 966 0	SHIM	100X110X1	2	
4	00 0211 964 0	SHIM	100X110X0,3	1	
4	00 0211 963 0	SHIM	100X110X0,1	2	
5	00 0237 442 0	HEXAGON HEAD BOLT	M8X25	12	
6	00 0827 580 0	COVER		1	
7	00 0827 577 1	HOUSING		1	
8	00 0238 183 0	SEALING RING	A16 X20	4	
9	00 0827 581 0	BREATHER VALVE	1021-04-401-00	1	
10	00 0234 829 0	TA.ROLLER BEARING	30209 J2/Q	2	
11	00 0213 961 0	SHAFT SEAL	AS 30X 55X10	1	
12	00 0851 341 0	SHAFT		1	
13	00 0211 034 0	ROTARY SHAFT SEAL	AS 60X 85X 8	1	
14	00 0243 661 0	TA.ROLLER BEARING	30212A	1	
15	00 0823 993 0	SLOTTED NUT	M55X1,5	1	
16	00 0244 014 1	STUD BOLT	M12X 45	2	
17	00 0244 351 0	SCREW PLUG	M16X1,5	3	
18	00 0823 994 0	SLOTTED NUT	M45X1,5	1	
19	00 0213 766 0	SHAFT SEAL	AS 40X 90X12	1	

1) Equipment

PR_P08_0020

Input gearbox 1,000 rpm

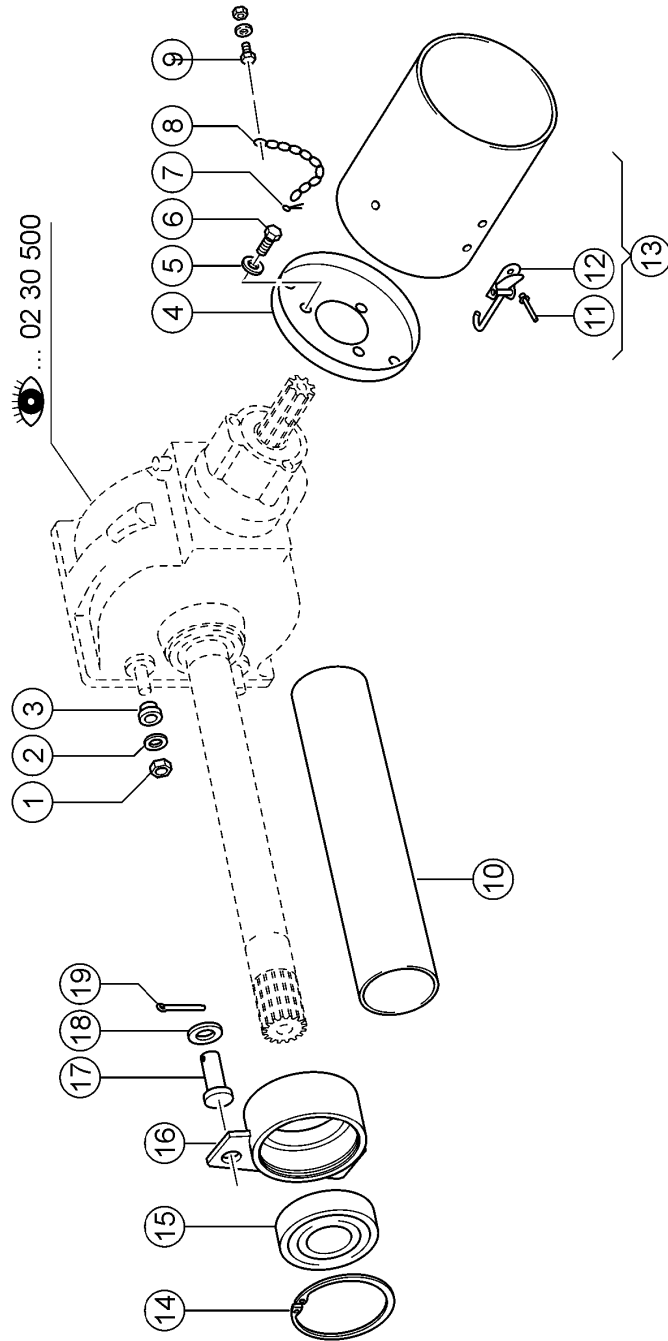

500 MAIN GEARBOX 1)

Pos.	Part No.	Description	Dimension	Quantity	Conditions
1	00 0236 172 0	HEXAGONAL NUT	M12	1	
2	00 0239 389 0	CONTACT WASHER	A12	1	
3	00 0810 117 0	BUSHING	D30X20	1	
4	00 0843 463 0	GUARD CUP	D206X1.5	1	
5	00 0239 387 0	CONTACT WASHER	A8-8,2X18X1,4	3	
6	00 0237 439 0	HEXAGON HEAD BOLT	M8X16	3	
7	00 0235 089 0	SPLIT PIN	4 X 22	1	2)
8	00 0608 099 0	ROUND STEEL CHAIN	G 3X16-17GL	1	2)
9	00 0233 918 0	HEXAGON HEAD BOLT	M 5X16	1	2)
9	00 0236 910 2	FLAT WASHER	5 -5,3X10X1	1	2)
9	00 0237 216 0	HEXAGONAL NUT	M05	1	2)
10	00 0868 298 0	PROTECTIVE TUBE	D 110 X 488LG	1	3)
10	00 0821 067 2	PROTECTIVE TUBE	D 110 X 493LG	1	4)
11	00 0237 922 1	BLIND RIVET	A 4X12	4	
12	00 0822 998 1	LOCK		2	
13	00 0822 996 0	PROTECT.TUBE CPL.		1	
14	00 0243 065 0	CIRCLIP	130X4	1	
15	00 0215 768 0	GRVD.BALL BEARING	6312-2RS*	1	
16	00 0843 465 0	BEARING		1	
17	00 0836 261 1	PIN	D25X48	1	
18	00 0234 238 0	WASHER	26X42X1	1	
19	00 0237 033 0	SPLIT PIN	6,3X 40	1	

1) Equipment

PR_P08_0010

Input gearbox 540 rpm

2) machine no.

+ up to 77100484

3) machine no.

+ from 77100965

4) machine no.

+ up to 77100964

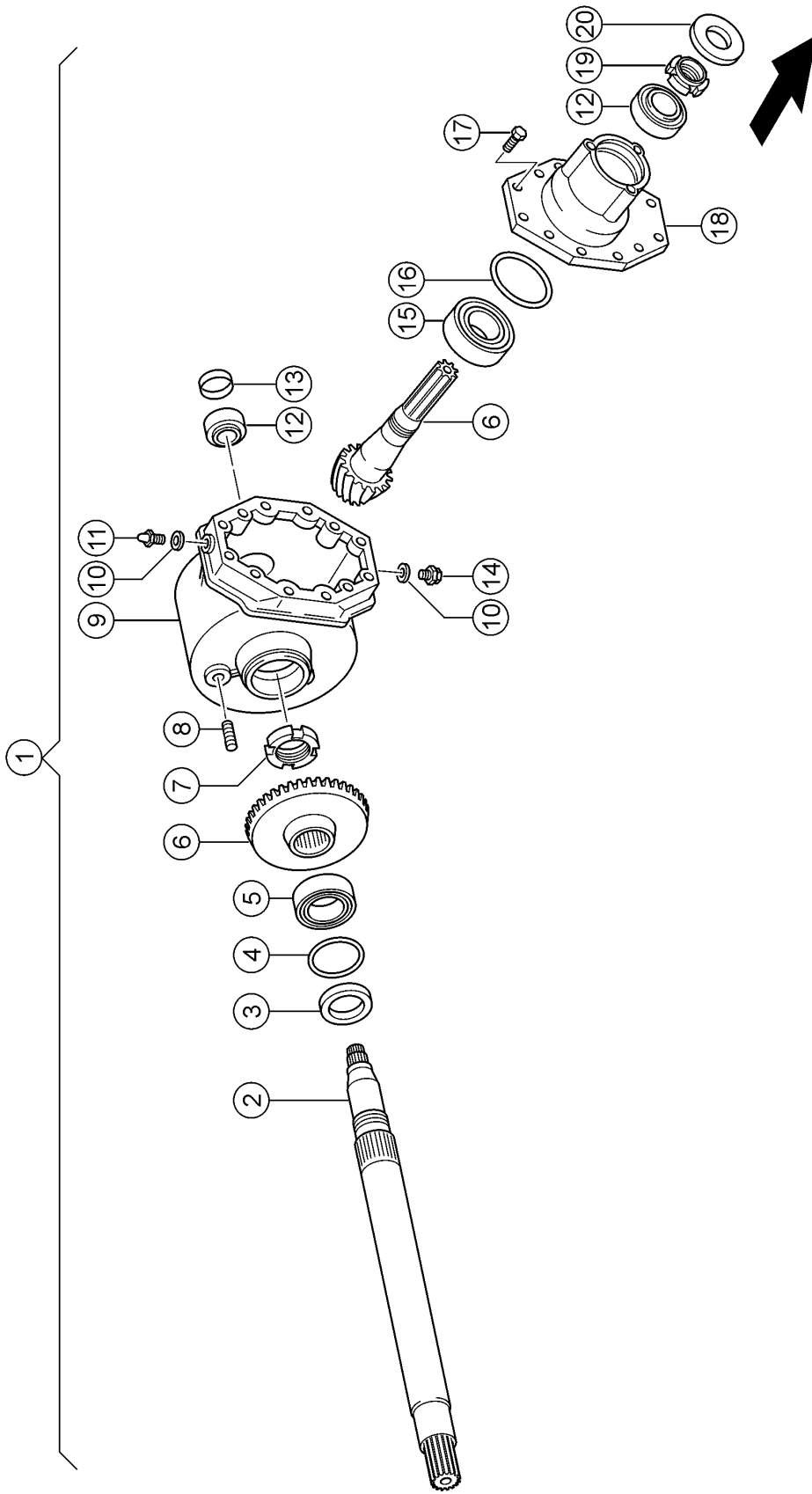

E0517 0230A500B 2

500 MAIN GEARBOX 1)

Pos.	Part No.	Description	Dimension	Quantity	Conditions
1	00 0843 460 1	GEARBOX	I=2,89	1	
2	00 0851 341 0	SHAFT		1	
3	00 0211 034 0	ROTARY SHAFT SEAL	AS 60X 85X 8	1	
4	00 0213 765 0	SHIM	85X 95X0,5	2	
4	00 0213 764 0	SHIM	85X 95X0,3	1	
4	00 0213 962 0	SHIM	85X 95X0,1	2	
5	00 0212 210 0	TA.ROLLER BEARING	330 12	1	
6	00 0823 942 0	BEVEL GEAR SET	I=2,88	1	
7	00 0823 993 0	SLOTTED NUT	M55X1,5	1	
8	00 0244 014 1	STUD BOLT	M12X 45	2	
9	00 0844 564 0	HOUSING		1	
10	00 0238 183 0	SEALING RING	A16 X20	4	
11	00 0940 866 0	BREATHER VALVE	M 16X1,5 M. SPRITZROHR	1	
12	00 0234 829 0	TA.ROLLER BEARING	30209 J2/Q	2	
13	00 0213 961 0	SHAFT SEAL	AS 30X 55X10	1	
14	00 0244 351 0	SCREW PLUG	M16X1,5	3	
15	00 0243 686 0	TA.ROLLER BEARING	30311A - 55X120X31,5	1	
16	00 0214 179 0	SHIM	110X120X0,1 ERS.D. 21417	2	
16	00 0214 180 0	SHIM	110X120X0,3 ERS.D. 21418	1	
16	00 0214 181 0	SHIM	110X120X0,5 ERS.D. 21418	1	
17	00 0237 572 0	HEXAGON HEAD BOLT	M12X35	8	
18	00 0844 565 0	BEARING HOUSING		1	
19	00 0823 994 0	SLOTTED NUT	M45X1,5	1	
20	00 0213 766 0	SHAFT SEAL	AS 40X 90X12	1	

1) Equipment

PR_P08_0010

Input gearbox 540 rpm

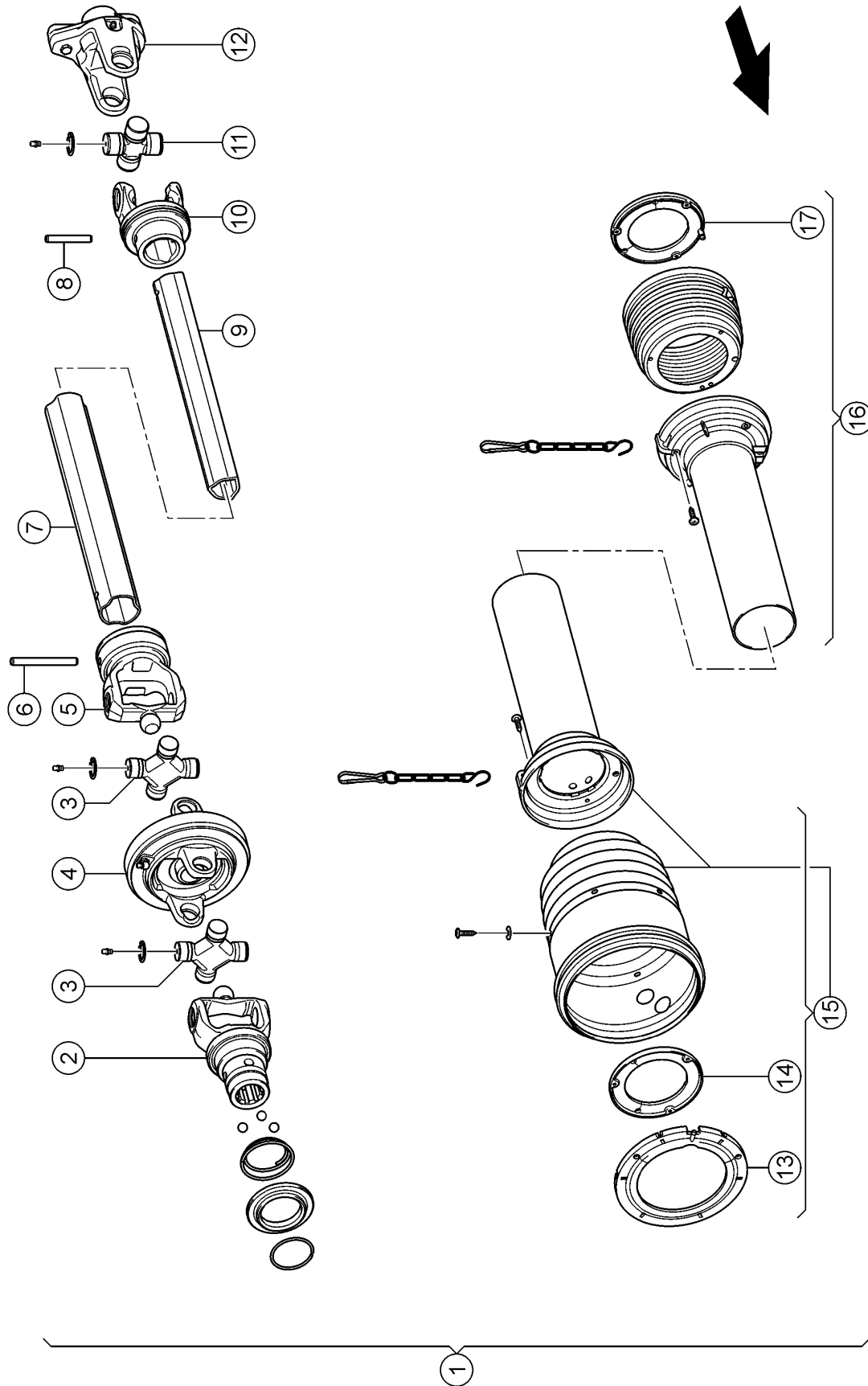

100 DRIVE SHAFT, MAIN DRIVE 1)

Pos.	Part No.	Description	Dimension	Quantity	Conditions
1	00 0836 975 0	DRIVE SHAFT		1	
2	00 0836 980 0	FORK		1	
3	00 0836 981 0	CENTRE CROSS ASS.		2	
4	00 0836 983 0	FORK		1	
5	00 0836 982 0	INNER FORK		1	
6	00 0234 862 0	SPRING PIN	10 X100	1	
7	00 0836 984 0	PROFILE TUBE EXT.		1	
8	00 0244 579 0	SPRING PIN	10X65	1	
9	00 0836 989 0	PROFILE TUBE INT.		1	
10	00 0941 903 0	FORK		1	
11	00 0138 307 0	CENTRE CROSS ASS.		1	
12	00 0836 985 0	SHEAR BOLT CLUTCH		1	
13	00 0844 557 0	RING		1	
14	00 0844 558 0	RING		1	
15	00 0836 978 0	GUARD HALF		1	
16	00 0836 979 0	GUARD HALF		1	
17	00 0836 346 0	RING		1	

1) Equipment

PR_M04_0010

Single wide-angle PTO drive shaft with shearbolt, 6 splines

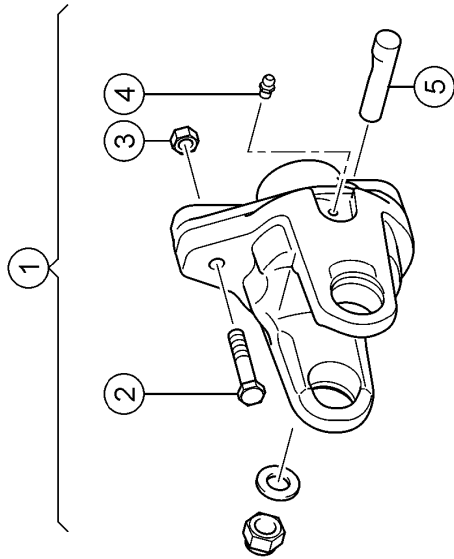

100 DRIVE SHAFT, MAIN DRIVE 1)

Pos.	Part No.	Description	Dimension	Quantity	Conditions
1	00 0836 985 0	SHEAR BOLT CLUTCH		1	
2	00 0235 534 1	HEXAGON HEAD BOLT	M10X50X29	1	
3	00 0237 947 0	HEX. NUT WITH CLAMP. PART	M10	1	
4	00 0236 942 0	GREASE NIPPLE	A S6X1	1	
5	00 0836 986 0	SLIDING PIN		1	
<hr/>					
1)	Equipment	PR_M04_0010	Single wide-angle PTO drive shaft with shearbolt, 6 splines		

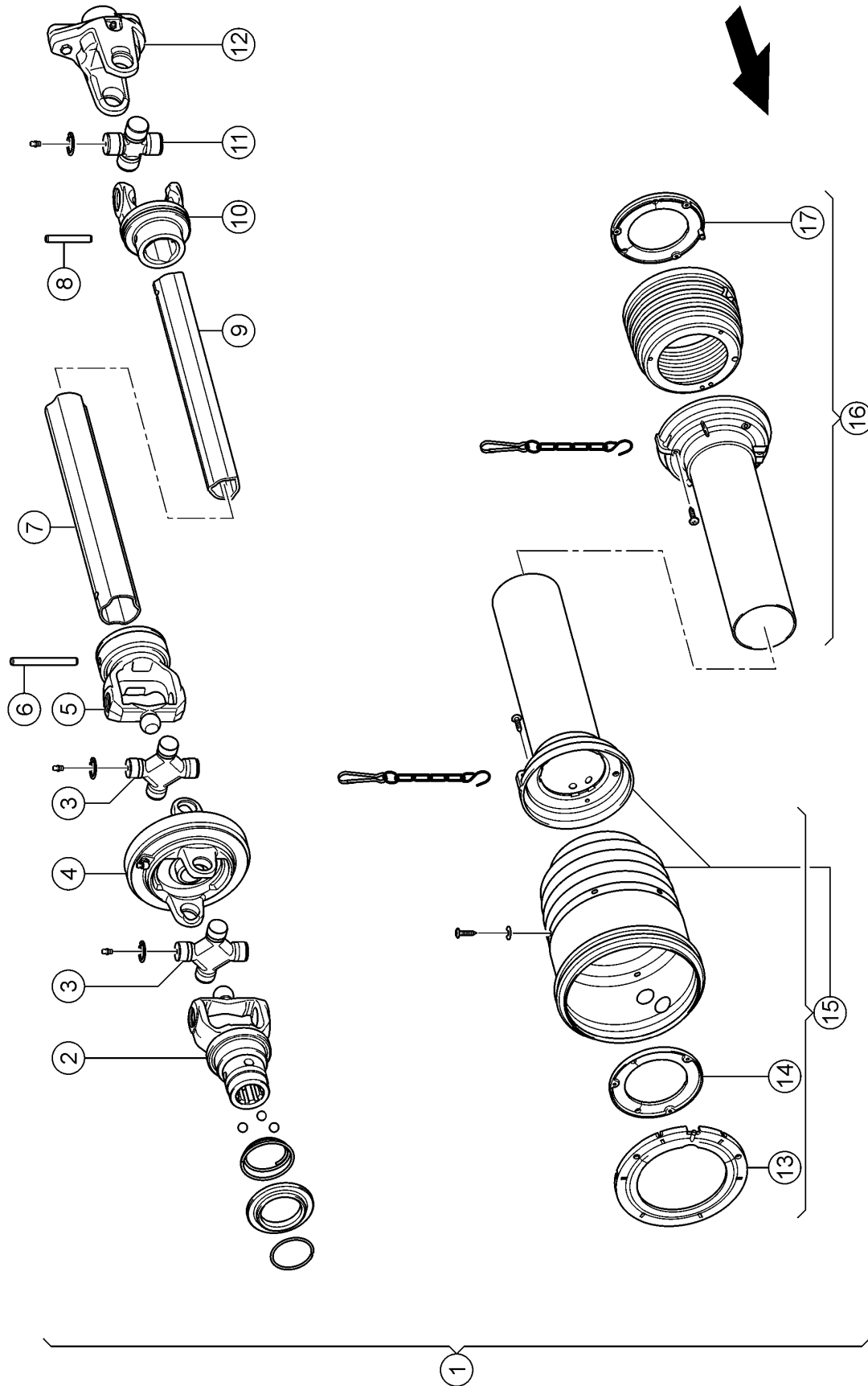

100 DRIVE SHAFT, MAIN DRIVE 1)

Pos.	Part No.	Description	Dimension	Quantity	Conditions
1	00 0843 751 0	DRIVE SHAFT ASSY.		1	
2	00 0843 775 0	FORK		1	
3	00 0843 765 0	CENTRE CROSS ASS.		2	
4	00 0843 767 0	FORK		1	
5	00 0843 766 0	INNER FORK		1	
6	00 0234 862 0	SPRING PIN	10 X100	1	
7	00 0843 768 0	TUBE		1	
8	00 0244 579 0	SPRING PIN	10X65	1	
9	00 0843 773 0	TUBE		1	
10	00 0843 772 0	FORK		1	
11	00 0843 771 0	CENTRE CROSS ASS.		1	
12	00 0843 769 0	SHEAR BOLT CLUTCH		1	
13	00 0844 557 0	RING		1	
14	00 0844 558 0	RING		1	
15	00 0843 762 0	GUARD HALF		1	
16	00 0866 429 0	GUARD		1	
17	00 0836 346 0	RING		1	

1) Equipment

PR_M04_0020

Single wide-angle universal drive shaft with shearbolt

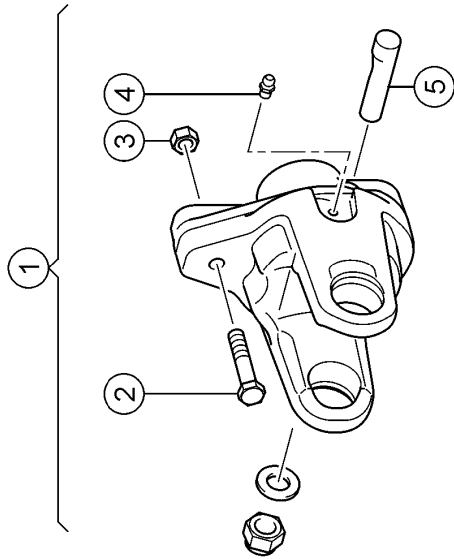

Thank you so much for reading.
Please click the “Buy Now!”
button below to download the
complete manual.



After you pay.

You can download the most
perfect and complete manual in
the world immediately.

Our support email:

ebooklibonline@outlook.com