



Service Repair Manual

Models

12M 2 MOTOR GRADER

Product: MOTOR GRADER

Model: 12M 2 MOTOR GRADER R9P

Configuration: 12M Series 2 Motor Grader - All Wheel Drive R9P00001-UP (MACHINE) POWERED BY C9.3 Engine

Disassembly and Assembly

12M Series 2, 140M Series 2 and 160M Series 2 Motor Graders Power Train

Media Number -KENR8899-03

Publication Date -01/05/2017

Date Updated -18/05/2017

i07077362

Transmission - Disassemble

SMCS - 3030-015; 3159-015; 3176-015

Disassembly Procedure

Table 1

Required Tools			
Tool	Part Number	Part Description	Qty
A	439-3940	Link Bracket	3
B	422-8733	Jack Stand Gp	3
C	1U-9202	Lever Puller Hoist	1
D	1P-1863	Retaining Ring Pliers	1
E	308-3470	Jack Stand Gp	2
F	140-7742	Sleeve	1
G	154-6181	Forcing Bolt	2
H	FT-2769	Table	1
J	4C-8156	Lifting Fixture	1
K	1U-6410	Three Jaw Puller	1
	1P-0510	Driver Gp	1
L	9U-7480	Compressing Tube	1
	5P-7970	Nut	1
	8T-4224	Hard Washer	1
	-		1

		Bolt M8 - 1.25 by 460mm	
M	8B-7548	Push-Puller Tool Gp	1
N	2P-8312	Retaining Ring Pliers	1
P	1P-2321	Combination Puller	1
	1P-0510	Driver Gp	1
R	189-0408	Shackle As	1
	3E-3882	Eyebolt	1
S	126-7175	Push-Puller Tool Gp	1
	4C-5653	Threaded Adapter	1
	1P-0510	Driver Gp	1

Start By:

- a. Remove the transmission.

NOTICE

Care must be taken to ensure that fluids are contained during performance of inspection, maintenance, testing, adjusting, and repair of the product. Be prepared to collect the fluid with suitable containers before opening any compartment or disassembling any component containing fluids.

Refer to Special Publication, NENG2500, "Dealer Service Tool Catalog" for tools and supplies suitable to collect and contain fluids on Cat[®] products.

Dispose of all fluids according to local regulations and mandates.

NOTICE

Keep all parts clean from contaminants.

Contaminants may cause rapid wear and shortened component life.

Note: Put identification marks on all harness assemblies for installation purposes.

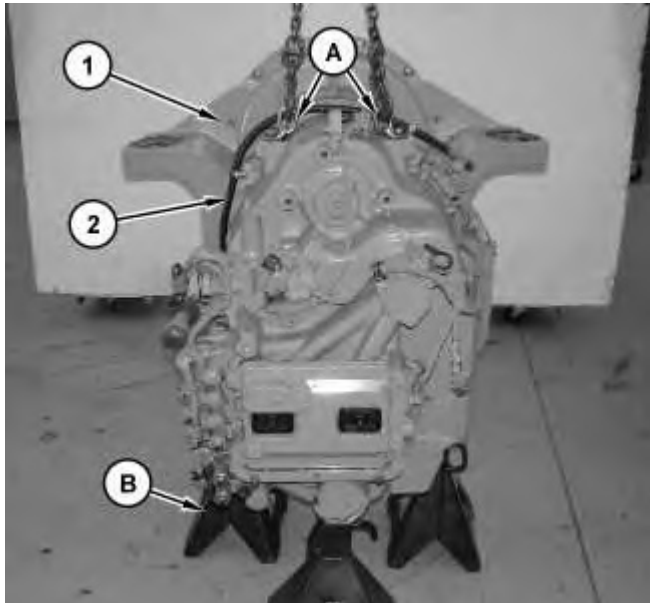

Illustration 1

g01386565

1. Attach Tooling (A) and a suitable lifting device to transmission (1). The weight of transmission (1) is approximately 862 kg (1900 lb). Use Tooling (A) and the suitable lifting device to position transmission (1) onto Tooling (B). Remove hose assembly (2).



Illustration 2

g01386568

2. Remove bolts (3) to remove control module (4) and spacers (5).

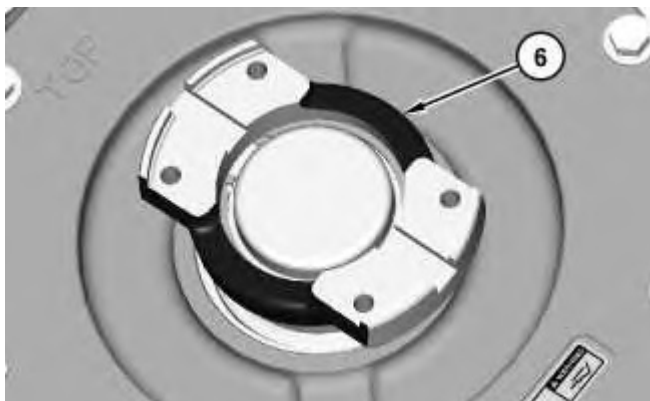

3. Remove yoke assembly (6).



4. Remove retaining ring (7).
5. Remove cup (8). Remove O-ring seal (9).

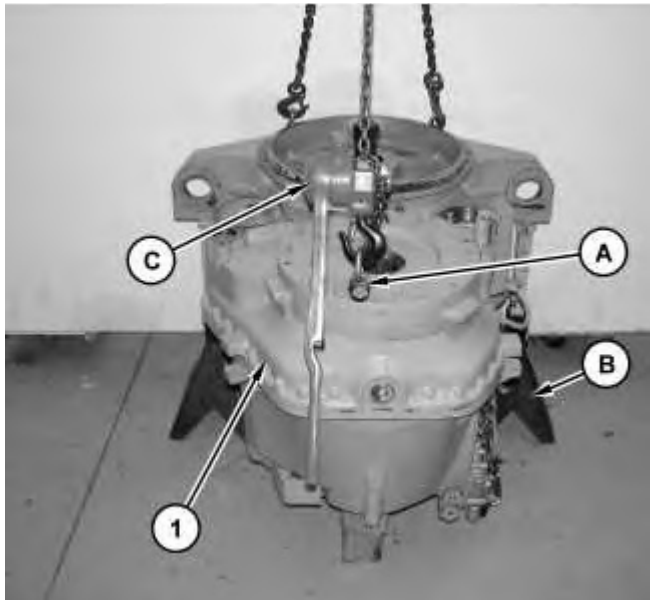

6. Attach Tooling (A), Tooling (C), and a suitable lifting device to transmission (1). Use Tooling (A), Tooling (C), and the suitable lifting device to position transmission (1) onto Tooling (B) and suitable cribbing. Position transmission (1) with the output shaft upward.

Thank you so much for reading.
Please click the “Buy Now!”
button below to download the
complete manual.



After you pay.

You can download the most
perfect and complete manual in
the world immediately.

Our support email:

ebooklibonline@outlook.com