



Service Repair Manual

Models

16M Motor Grader

Product: MOTOR GRADER

Model: 16M MOTOR GRADER B9H

Configuration: 16M Motor Grader B9H00001-UP (MACHINE) POWERED BY C13 Engine

Disassembly and Assembly 16M Motor Grader Power Train

Media Number -KENR6019-08

Publication Date -01/08/2018

Date Updated -14/08/2018

i06791672

Rear Axle, Differential and Final Drive - Disassemble

SMCS - 3258-015; 3278-015; 3282-015-RE; 4050-015; 4068-015

Disassembly Procedure

Table 1

Required Tools			
Tool	Part Number	Part Description	Qty
A	138-7575	Link Bracket	4
B	140-7742	Sleeve	2
C	1U-9200	Lever Puller Hoist	1
D	154-6182	Forcing Bolt	3
	154-6360	Forcing Bolt ⁽¹⁾	3
		Reaction Plate 1/4 in. Steel	3
E	1D-4601	Bolt	2
	4K-0367	Full Nut	2
	150-1782	Crossblock	1
	5F-7351	Nut	1
	5F-7366	Forcing Screw	1
	1P-0520	Driver Gp	1
	3H-0465	Push-Puller Plate	2
F	138-7574	Link Bracket	2

G	8B-7551	Bearing Puller Gp	1
	1P-5546	Crossarm	1
	3H-0465	Push-Puller Plate	2
	5F-7366	Forcing Screw	1
H	1U-6692	Socket Wrench As	1
J	154-6183	Forcing Bolt	3
K	1U-6405	Three Jaw Puller	1

⁽¹⁾ **154-6360** Forcing Bolt is used for the latest ring gear.

Start By:

- a. Remove the rear axle, differential, and final drive. Refer to Disassembly and Assembly, "Rear Axle, Differential, and Final Drive - Remove".

NOTICE

Keep all parts clean from contaminants.

Contaminants may cause rapid wear and shortened component life.

Note: Inspect the O-ring seals. Replace the O-ring seals that are worn or damaged.

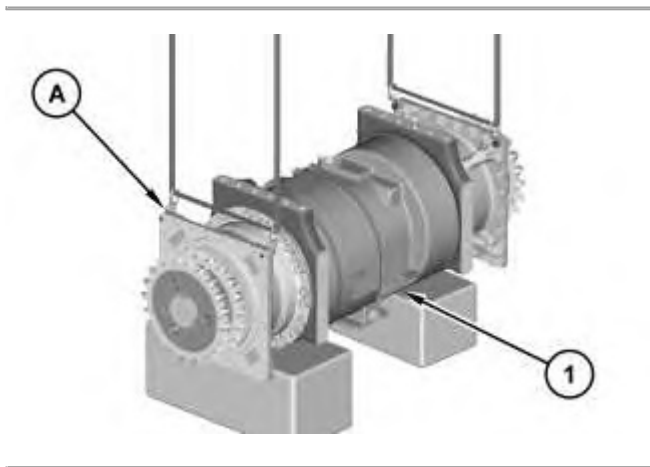

Illustration 1

g01351806

1. Use Tooling (A) and two suitable lifting devices to position rear axle, differential, and final drive (1) onto suitable blocking. The weight of rear axle, differential, and final drive (1) is approximately 1588 kg (3500 lb).
-

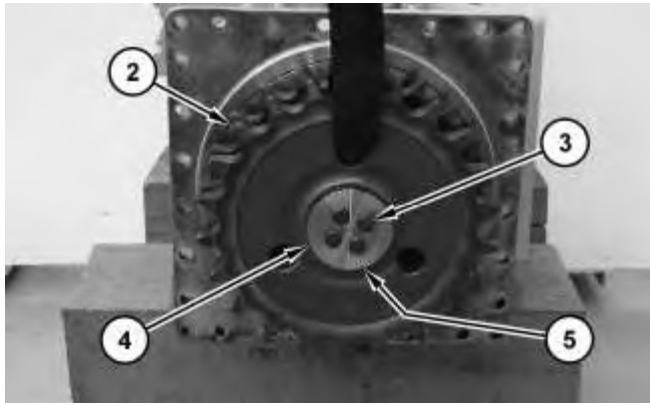

Illustration 2

g01351767

2. Attach Tooling (B) and a suitable lifting device onto sprocket (2). The weight of sprocket (2) is approximately 23 kg (51 lb).
3. Remove bolts (3), retainer (4), shims (5), and sprocket (2).

Note: Note the quantity and the order of shims (5).



Illustration 3

g01351809

4. Attach Tooling (B) and a suitable lifting device onto sprocket (6). The weight of sprocket (6) is approximately 23 kg (51 lb).
 5. Remove sprocket (6).
-



Illustration 4

g01351900

6. Remove bearing cone (7).

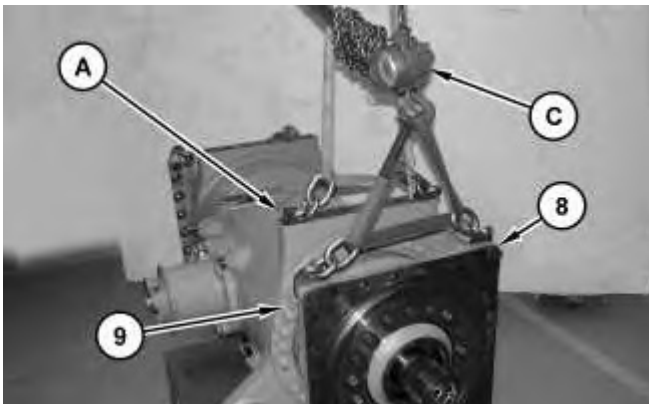

Illustration 5

g01351906

7. Attach Tooling (A), Tooling (C), and two suitable lifting devices onto final drive housing (8). The weight of final drive housing (8) is approximately 254 kg (560 lb). Remove nuts (9).

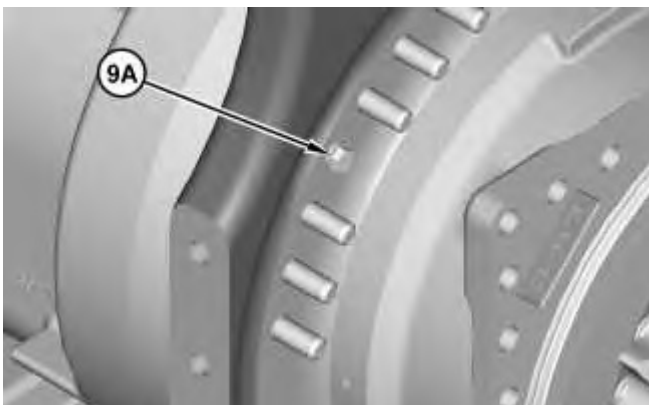

Illustration 6

g01425110

Thank you so much for reading.
Please click the “Buy Now!”
button below to download the
complete manual.



After you pay.

You can download the most
perfect and complete manual in
the world immediately.

Our support email:

ebooklibonline@outlook.com