



Service Repair Manual

Models

323F L Excavator

Product: EXCAVATOR

Model: 323F L EXCAVATOR PLB

Configuration: 323F L Excavators PLB00001-UP (MACHINE) POWERED BY C7.1 Engine

Disassembly and Assembly

C7.1 Engines for Caterpillar Built Machines

Media Number -UENR4468-15

Publication Date -01/06/2015

Date Updated -30/10/2018

i07167344

Front Cover - Remove and Install

SMCS - 1166-010

Removal Procedure

Start By:

- a. Remove the crankshaft pulley. Refer to Disassembly and Assembly, "Vibration Damper and Pulley - Remove" for the correct procedure.
 - b. If the engine is equipped with a fan, remove the fan. Refer to Disassembly and Assembly, "Fan - Remove and Install" for the correct procedure.
-

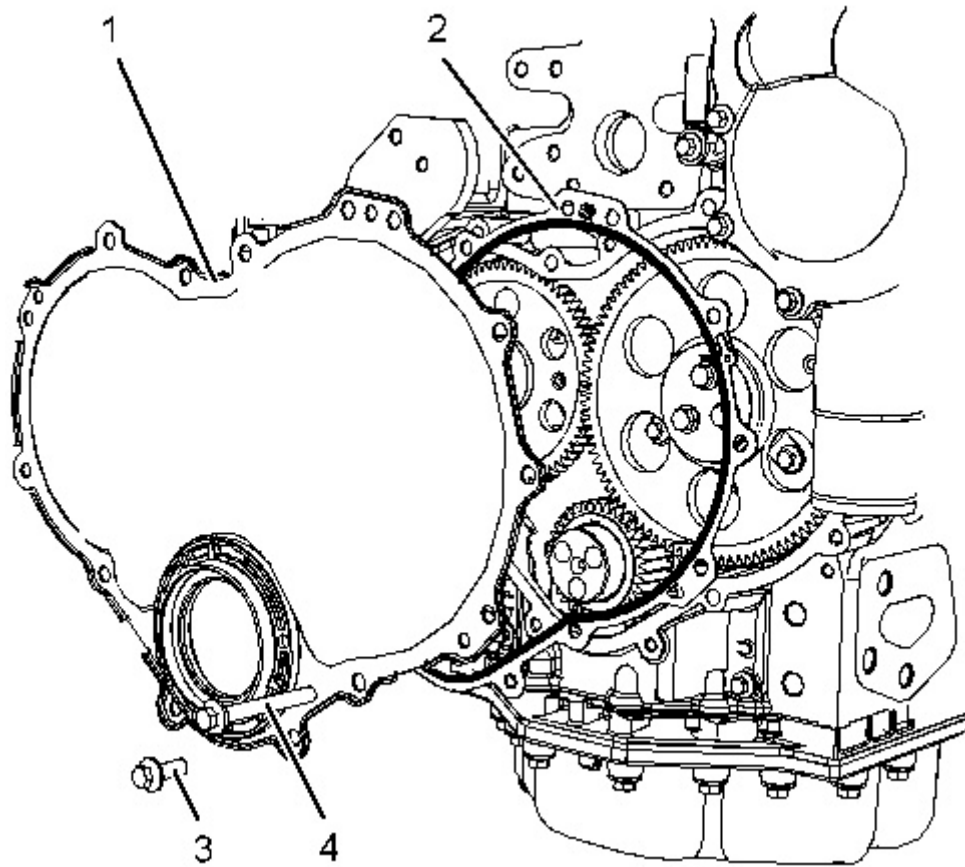

Illustration 1

g01992013

1. Remove the front seal from the front cover. Refer to Disassembly and Assembly, "Crankshaft Front Seal - Remove and Install" for the correct procedure.
2. Remove bolts (3) and bolts (4). Identify the positions of bolts of different length.
3. Remove front cover (1) from the front housing.
4. Remove gasket (2) from front cover (1).

Installation Procedure

Table 1

Required Tools			
Tool	Part Number	Part Description	Qty
A	-	Guide Stud M8 by 70 mm	2
B	367-3535	Front Cover Alignment Tool	1

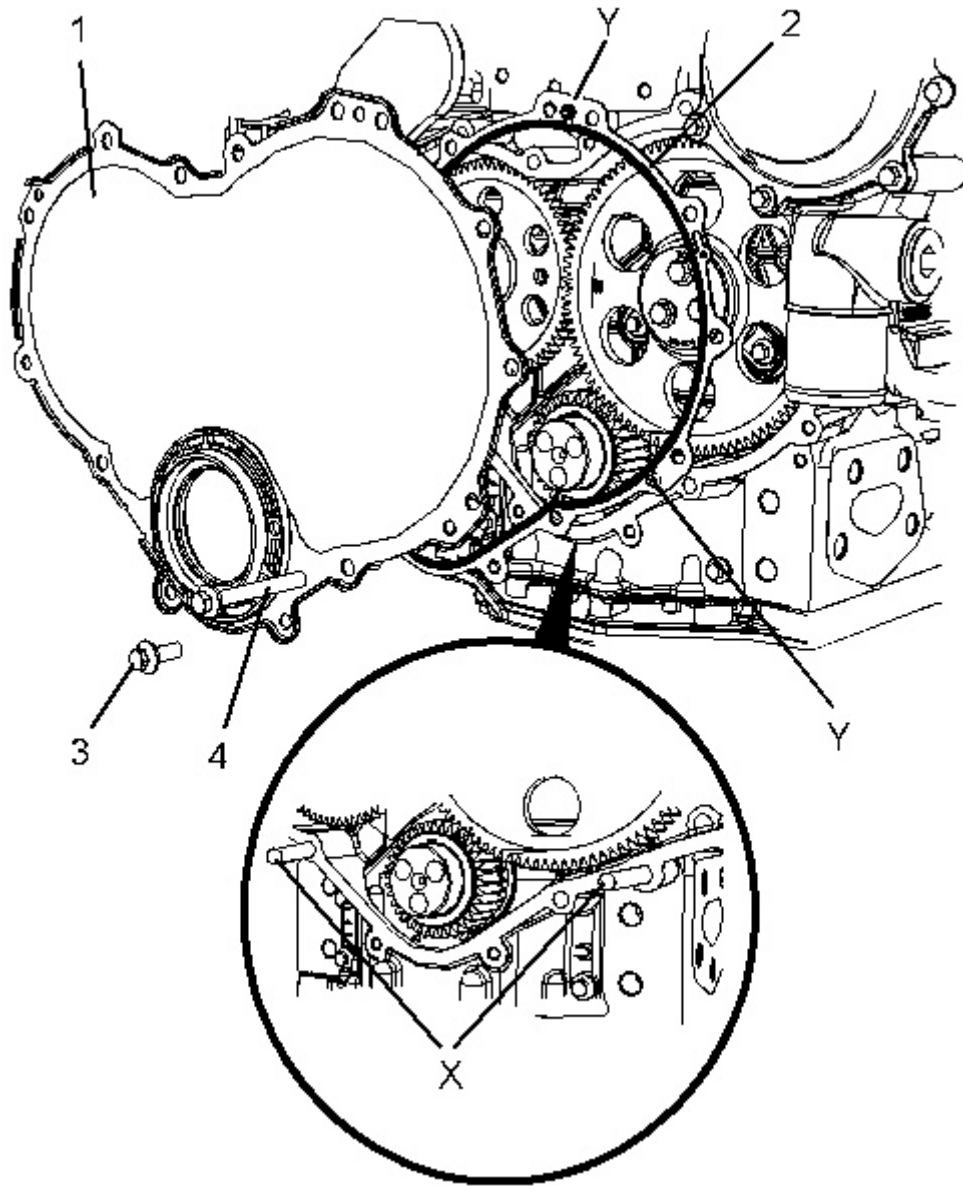

Illustration 2

g02190133

1. Thoroughly clean the gasket surface of the front housing.
2. If the original front cover is installed, follow Step 2.a through Step 2.b.
 - a. Thoroughly clean front cover (1).
 - b. Install a new gasket (2) to front cover (1). Engage Locators (Y) into the holes in the front cover.
3. Install Tooling (A) into Holes (X) in the front housing.
4. Use Tooling (A) to position the front cover assembly onto the front housing.
5. Install bolts (3) and bolts (4) finger tight. Ensure that the bolts of different length are installed in the correct positions.

6. Install a new front seal to the front cover. Refer to Disassembly and Assembly, "Crankshaft Front Seal - Remove and Install" for the correct procedure.
7. Use Tooling (B) to align the front cover.
8. Remove Tooling (A) and install remaining bolts (4).
9. Tighten bolts (3) and bolts (4) to a torque of 22 N·m (195 lb in).
10. Remove Tooling (B) from the front cover.

End By:

- a. Install the crankshaft pulley. Refer to Disassembly and Assembly, "Vibration Damper and Pulley - Install" for the correct procedure.
- b. If the engine was equipped with a fan, install the fan. Refer to Disassembly and Assembly, "Fan - Remove and Install" for the correct procedure.

Thank you so much for reading.
Please click the “Buy Now!”
button below to download the
complete manual.



After you pay.

You can download the most
perfect and complete manual in
the world immediately.

Our support email:

ebooklibonline@outlook.com