



Service Repair Manual

Models

330D and 330D L Excavator

Product: EXCAVATOR

Model: 330D EXCAVATOR EAH

Configuration: 330D & 330D L Excavators EAH00001-UP (MACHINE) POWERED BY C9 Engine

Disassembly and Assembly

330D, 336D, 336D2, 340D and 340D2 Excavators and 336D MHPU Mobile Hydraulic Power Unit Machine Systems

Media Number -REN8648-30

Publication Date -01/03/2015

Date Updated -15/08/2018

i06560081

Swing Drive - Disassemble

SMCS - 5459-015

Disassembly Procedure

Table 1

Required Tools			
Tool	Part Number	Part Description	Qty
A	138-7573	Link Bracket	2
B	1U-8221	Nylon Sling	1
C	5P-5197	Pliers	1

Start By:

- a. Remove the swing drive. Refer to Disassembly and Assembly, "Swing Drive - Remove"

NOTICE

Care must be taken to ensure that fluids are contained during performance of inspection, maintenance, testing, adjusting, and repair of the product. Be prepared to collect the fluid with suitable containers before opening any compartment or disassembling any component containing fluids.

Refer to Special Publication, NENG2500, "Dealer Service Tool Catalog" for tools and supplies suitable to collect and contain fluids on Cat[®] products.

Dispose of all fluids according to local regulations and mandates.

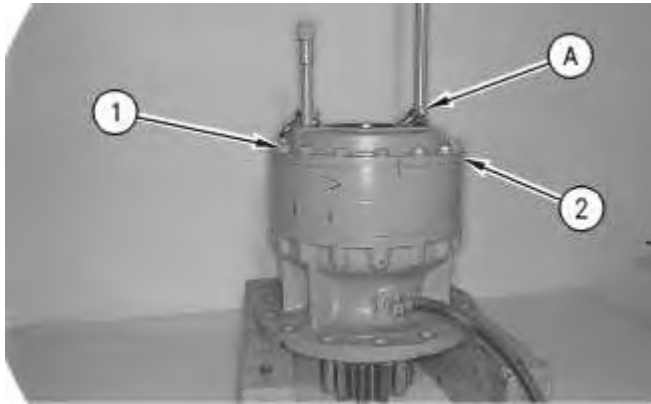

Illustration 1

g00518369

1. Position the swing drive on suitable cribbing, as shown. The weight of the swing drive is approximately 281 kg (620 lb).
2. Put an alignment mark on the cover and the housing of the swing drive for assembly purposes.
3. Remove bolts (1) and cover (2).
4. Install Tooling (A) to cover (2).

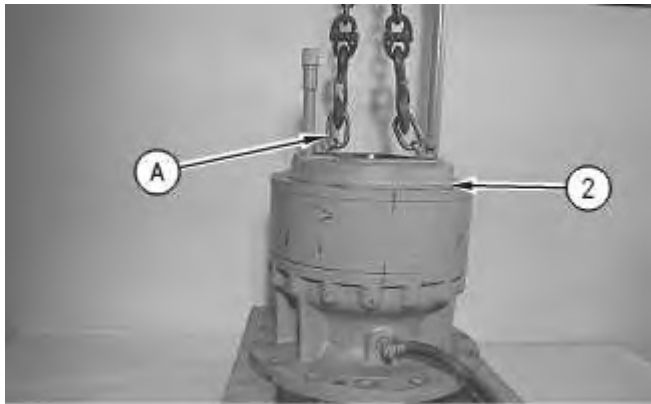

Illustration 2

g00518372

5. Use a suitable lifting device and Tooling (A) to remove cover (2) from the ring gear of the swing drive.
-

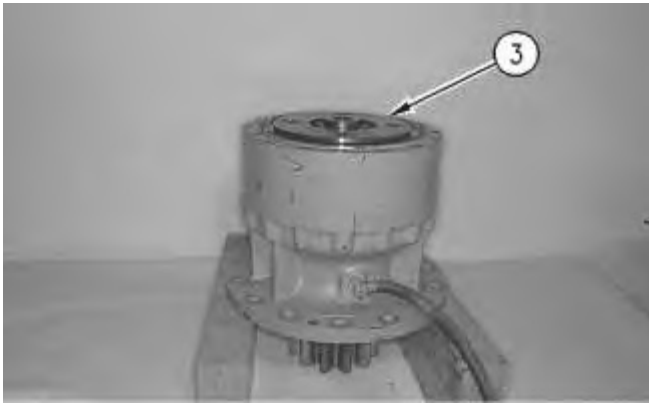

Illustration 3

g00518397

6. Use two people to remove carrier assembly (3). The weight of the carrier assembly is approximately 23 kg (50 lb).
7. Use the following procedure to disassemble carrier assembly (3).

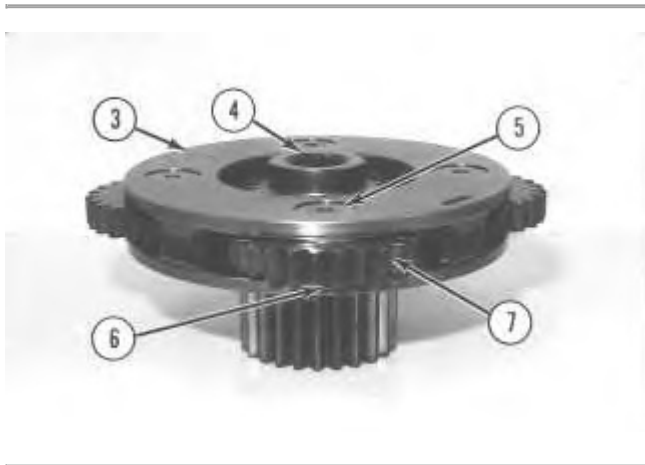

Illustration 4

g00518398

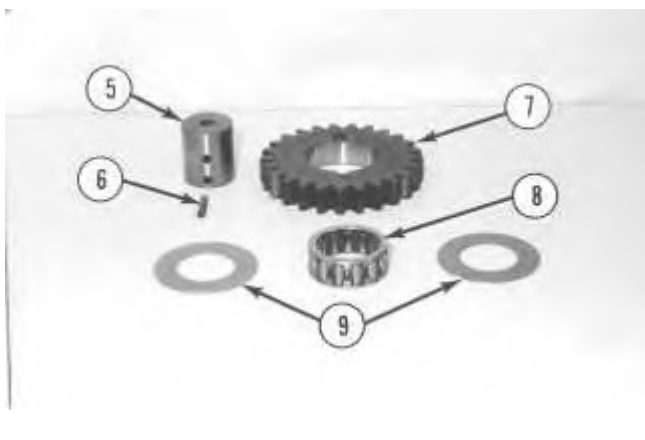

Illustration 5

g00518400

- a. Remove sun gear (4) from carrier assembly (3).
- b. Drive spring pin (6) into planetary shaft (5) with a hammer and a punch.

- c. Remove planetary shaft (5), thrust washers (9), and planetary gear (7) from the carrier assembly.
- d. Remove bearing (8) from planetary gear (7).
- e. Remove spring pin (6) from planetary shaft (5) with a hammer and a punch.
- f. Repeat Steps 7.a through 7.e to remove the other three planetary gears from the carrier assembly.

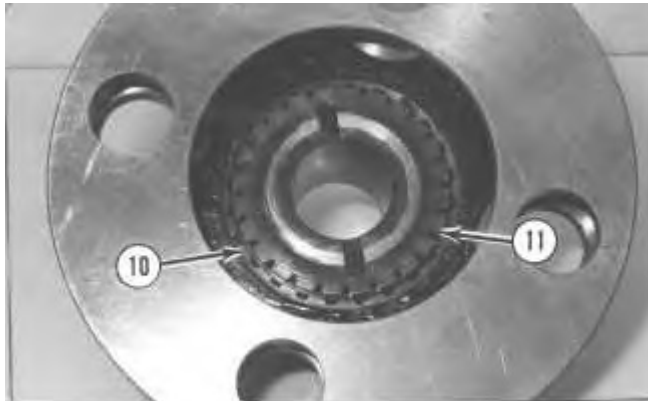

Illustration 6

g00518543

- g. Remove retaining ring (10) with a screwdriver. Remove gear (11) from carrier (3).

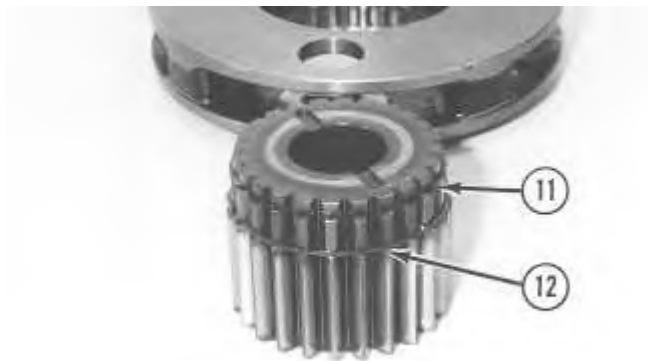

Illustration 7

g00518549

- h. Remove retaining ring (12) from gear (11).
-

Thank you so much for reading.
Please click the “Buy Now!”
button below to download the
complete manual.



After you pay.

You can download the most
perfect and complete manual in
the world immediately.

Our support email:

ebooklibonline@outlook.com