



Service Repair Manual

Models

349D2 L Excavator

Product: EXCAVATOR

Model: 349D2 L EXCAVATOR YAE

Configuration: 349D2 L Excavators YAE00001-UP (MACHINE) POWERED BY C13 Engine

Disassembly and Assembly 345D, 349D and 349D2 Excavators and 345D MHPU and 349D MHPU Mobile Hydraulic Power Units Machine Systems

Media Number -REN9574-10

Publication Date -01/08/2014

Date Updated -18/09/2018

i03778971

Travel Motor - Assemble

SMCS - 4351-016

Assembly Procedure

Table 1

Required Tools			
Tool	Part Number	Part Description	Qty
A	3E-3879	Eyebolt	1
D	4C-8359	Eyebolt	1
F	1P-1862	Pliers	1
G	1P-0510	Driver Group	1
J	4C-4030	Thread Lock Compound	1
K	180-6533	Seal Driver	1
L	6V-7030	Micrometer Depth Gauge	1
M	8T-0447	Calipers	1
N	1U-6396	O-Ring Assembly Compound	1

NOTICE

Keep all parts clean from contaminants.

Contamination of the hydraulic system with foreign material will reduce the service life of the hydraulic system components.

To prevent contaminants from entering the hydraulic system, always plug or cap the lines, fittings, or hoses as they are disconnected. Cover any disassembled components and clean them properly before assembly.

Clean the hydraulic system properly after any major component exchange or especially after a component failure, to remove any contamination.

Note: If a failure occurs, an accurate diagnosis of the cause can prevent a recurrence. Information is available to analyze failures for piston pumps and motors. Refer to Special Publication, SEBD0641, "Analyzing Axial Piston Pump and Motor Failures".

Note: Inspect all parts. If any parts are worn or damaged use new parts for replacement. The installation of used parts during reconditioning is acceptable. Reuse and salvage information is available on piston pumps. Refer to Guideline For Reusable Parts and Salvage Operations, SEBF8032, "Piston Pumps and Motors". During reconditioning, correct any conditions that might have caused the original failure.

Note: O-ring seals, gaskets, and seals should always be replaced. A used O-ring seal may not have the same sealing properties as a new O-ring seal. Use Tooling (H) during the assembly procedure.

Note: Apply a light film of "10W" oil to all components before assembly.

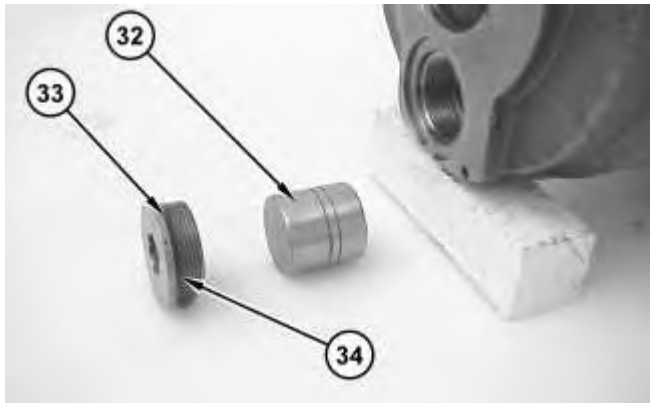

Illustration 1

g01204890

1. Install O-ring seal (34) on plug (33).
 2. Install piston (32) and the plug in the travel motor body. Tighten the plug to a torque of $430 \pm 40 \text{ N}\cdot\text{m}$ ($317 \pm 30 \text{ lb ft}$).
-

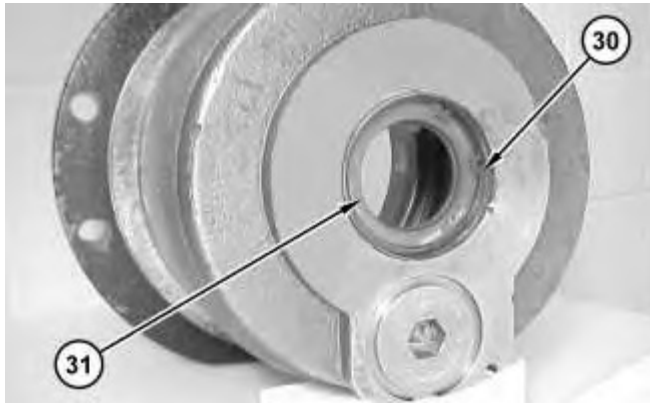

Illustration 2

g01204916



Illustration 3

g01204919

3. Apply a thin coat of Tooling (J) on the outer surfaces of lip seal (31).
4. Use Tooling (K) and a suitable hammer to drive the lip seal into the travel motor body. Drive the seal downward until Tooling (K) makes contact with the travel motor housing.
5. Use Tooling (F) to install retaining ring (30) to the shaft end of the travel motor body.



Illustration 4

g01204923

6. Install keys (29) inside the travel motor body.

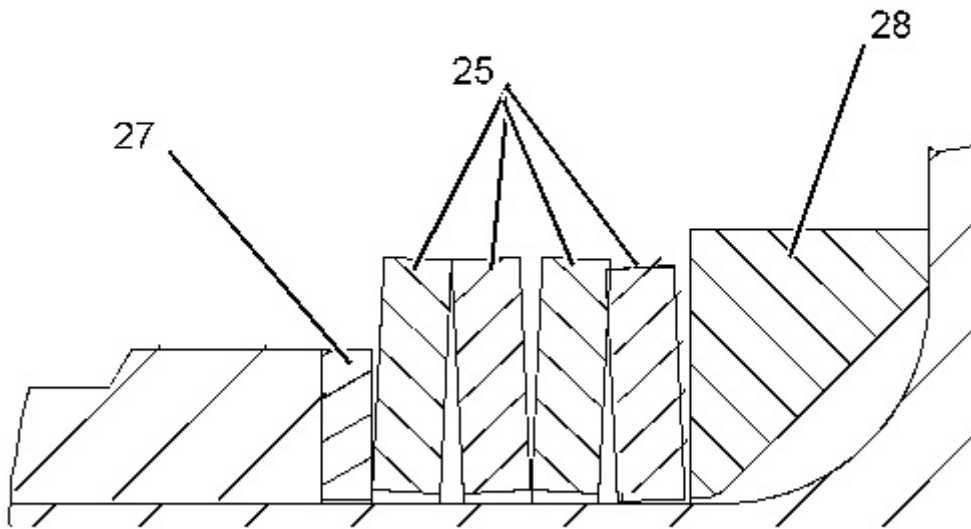

Illustration 5

g01204924

7. Assemble washers (25), inner spacer (28) and outer spacer (27) in the proper orientation, as shown.



Illustration 6

g01204931

8. Use Tooling (L) to measure the distance from the outer spacer to the surface of the table. The distance should be 22.1 ± 0.6 mm (0.87 ± 0.02 inch). If this measurement is off, check orientation of the washers. If orientation is correct, replace washers and spacers with new parts.
-

Thank you so much for reading.
Please click the “Buy Now!”
button below to download the
complete manual.



After you pay.

You can download the most
perfect and complete manual in
the world immediately.

Our support email:

ebooklibonline@outlook.com