



Service Repair Manual

Models

390F and 390F L Excavator

Product: EXCAVATOR

Model: 390F EXCAVATOR HNG

Configuration: 390F L Excavator HNG00001-UP (MACHINE) POWERED BY C18 Engine

Disassembly and Assembly C15 and C18 Engines for Caterpillar Built Machines

Media Number -UENR0132-11

Publication Date -01/08/2015

Date Updated -03/04/2018

i05949761

Gear Group (Front) - Remove and Install

SMCS - 1206-010

Removal Procedure

Table 1

Required Tools			
Tool	Part Number	Part Description	Qty
A	1P-0510	Driver Gp	1
B	8T-2998	Lubricant	-
C	8T-9022	Silicone Gasket	-
D	9S-3263	Thread Lock Compound	-

Start By:

- a. Remove the front housing.
- b. Remove the air compressor, if necessary.
- c. Remove the water pump, if necessary.

NOTICE

Keep all parts clean from contaminants.

Contaminants may cause rapid wear and shortened component life.

NOTICE

Do not turn the crankshaft or the camshaft while the camshaft gear is removed. If the front gear group is not correctly timed during installation, interference can occur between the pistons and the valves, resulting in damage to the engine.

Note: Be sure to mark the orientation of each of the gears for installation purposes.

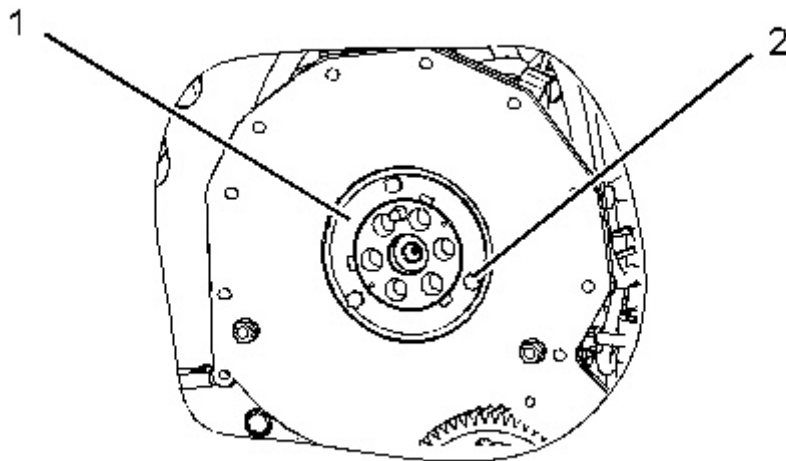
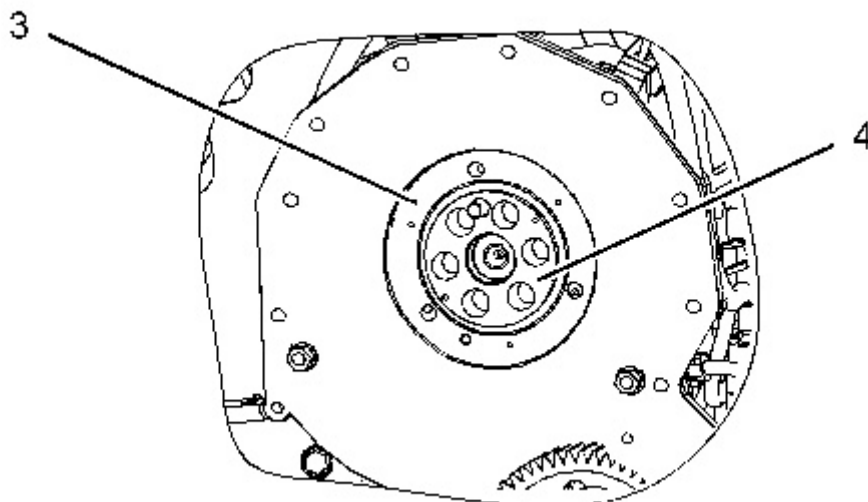

Illustration 1

g01008429

1. Remove bolts (2) and thrust plate (1).
-



2. Remove sealing plate (3) and adapter (4).

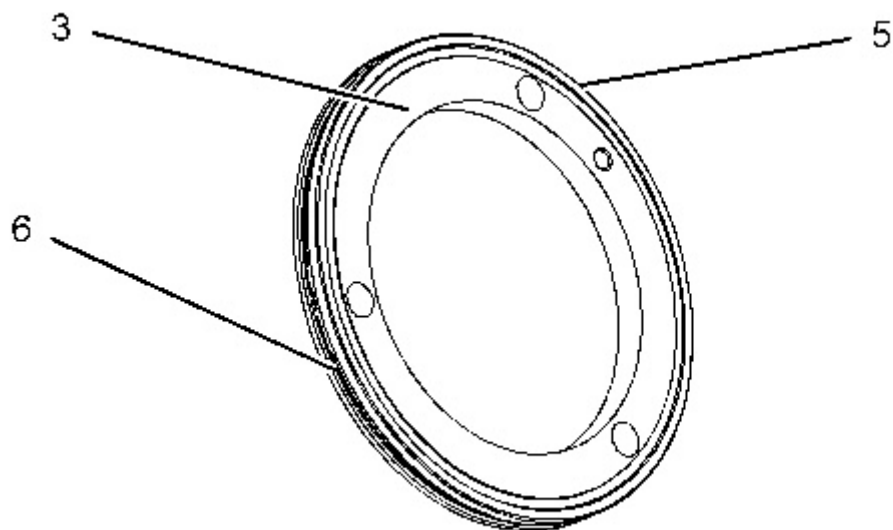

3. Remove O-ring seal (5) and O-ring seal (6) from sealing plate (3).

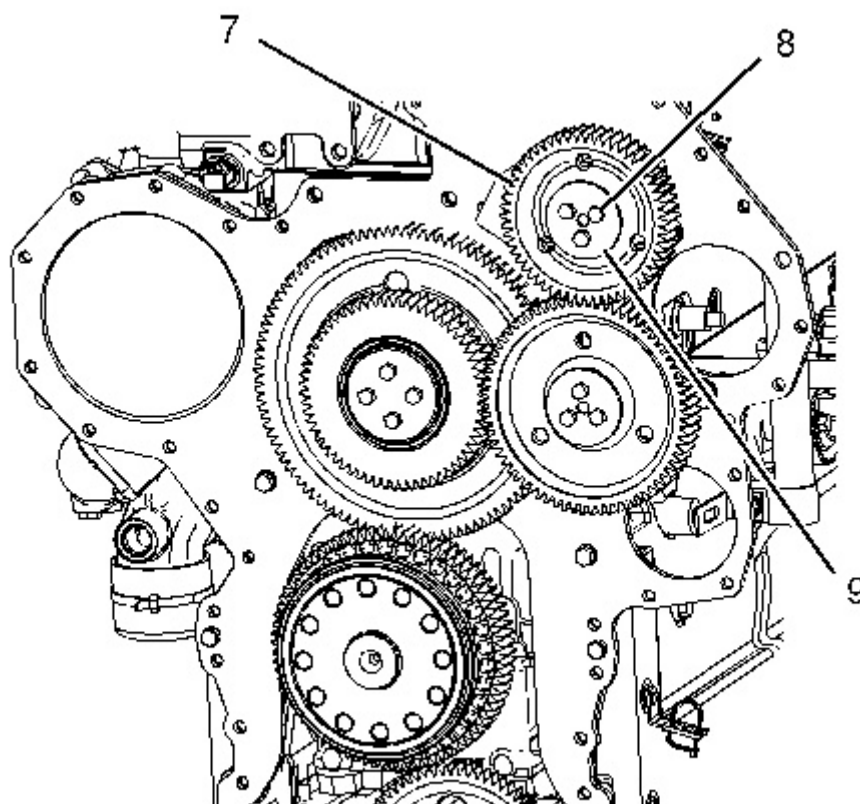

4. Remove bolts (8), plate (9), and adjustable idler gear assembly (7).
 5. Use Tooling (A) and remove the sleeve bearing from adjustable idler gear assembly (7).
-

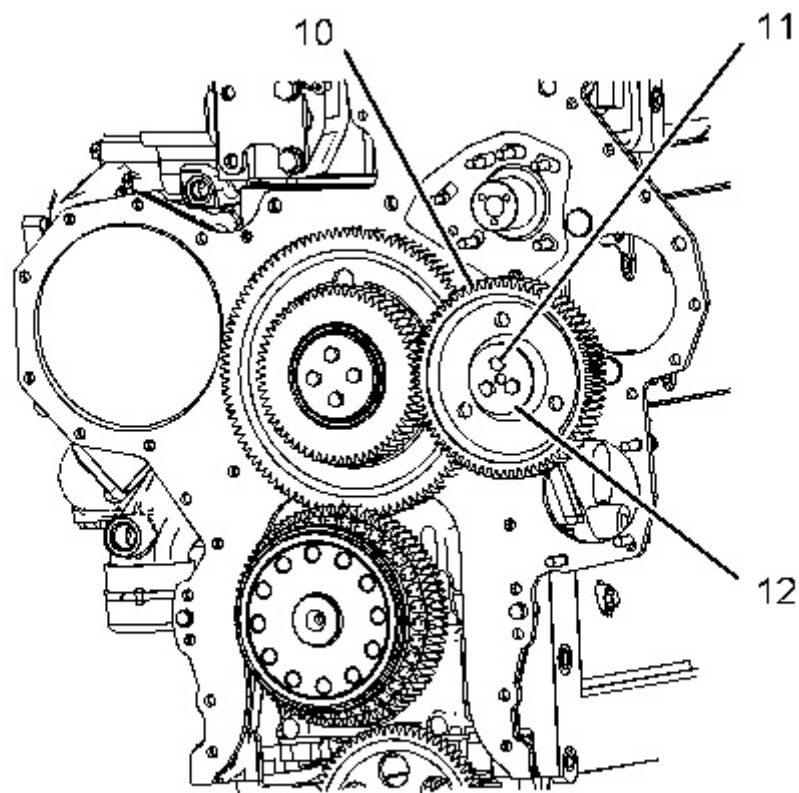

6. Remove bolts (11), plate (12), and idler gear assembly (10).
 7. Use Tooling (A) and remove the sleeve bearing from idler gear assembly (10).
-

Thank you so much for reading.
Please click the “Buy Now!”
button below to download the
complete manual.



After you pay.

You can download the most
perfect and complete manual in
the world immediately.

Our support email:

ebooklibonline@outlook.com