

Product: EXCAVATOR

Model: 538 EXCAVATOR JEY

Configuration: 538 Forest Machine Log Loader JEY00001-UP (MACHINE) POWERED BY C7.1 Engine

## Disassembly and Assembly 538 LL GF Forest Machine Machine Systems

Media Number -M0071454-01

Publication Date -01/08/2017

Date Updated -02/08/2017

i06723435

### Final Drive - Assemble

SMCS - 4050-016

### Assembly Procedure

Table 1

| Required Tools |             |                               |     |
|----------------|-------------|-------------------------------|-----|
| Tool           | Part Number | Part Description              | Qty |
| A              | 1P-2420     | Transmission Repair Stand     | 1   |
| B              | 439-3938    | Link Bracket                  | 2   |
| C              | 1P-1863     | Retaining Ring Pliers         | 1   |
| E              | 439-3939    | Link Bracket As               | 2   |
| G              | 1U-5933     | Duo-Cone Seal Installer As    | 1   |
| H              | -           | Loctite C5A Copper Anti-Seize | -   |
| J              | -           | Loctite 5188                  | -   |
| K              | 369-9451    | Grease                        | -   |
| L              | -           | Loctite 243                   | -   |
| M              | FT-2770     | Leak Down Test Tool           | 1   |

**Note:** Cleanliness is an important factor. Before assembly, all parts should be thoroughly cleaned in cleaning fluid. Allow the parts to air dry. Wiping cloths or rags should not be used to dry parts. Lint may be deposited on the parts which may cause later trouble. Inspect all parts. If any parts are worn or damaged, use new parts for replacement. All disassembly and all assembly procedures must be performed on a clean work surface and in a clean hydraulic area. Always keep cleaned parts covered and protected.

**Note:** O-rings, gaskets, and seals should always be replaced. A used O-ring may not have the same sealing properties as a new O-ring. Use Tooling (K) during the assembly procedure.

**Note:** Apply a light film of hydraulic oil to all components before assembly.

1. If necessary, install the sprocket.



Illustration 1

g01760833

2. Lower the temperature of bearings (44) and (46).
3. Use a suitable press to install bearings (44) and (46). Make sure that bearings (44) and (46) contact the counterbore in housing (39).
4. Use the following procedure to preload the bearings and determine the correct thickness of shims.

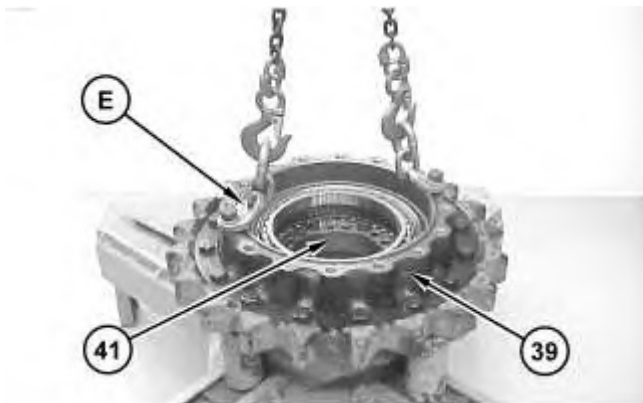

Illustration 2

g01760875

- a. Attach Tooling (E) and a suitable lifting device to housing (39). Install housing (39) onto motor housing (41).
  - b. Position housing (39) and motor housing (41) onto a suitable press. The combined weight of housing (39) and motor housing (41) is approximately 82 kg (180 lb).
-

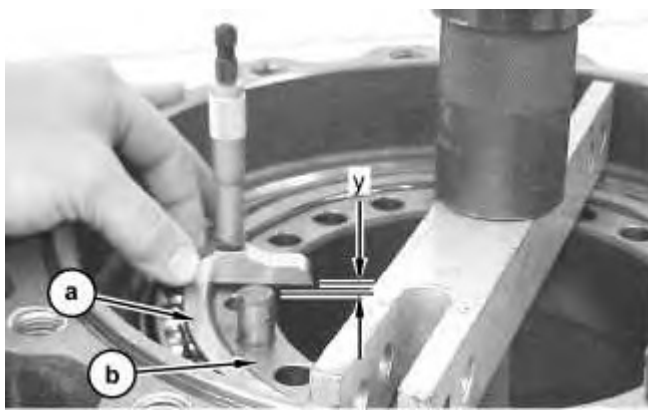

Illustration 3

g01760892

- (a) Bearing surface
- (b) Housing surface

- c. Use a suitable press and a spacer to apply a load of 4000 kg (8820 lb) on the bearings. Rotate the housing to seat the bearings.
- d. Reduce the load on the bearings to  $1000 \pm 100$  kg ( $2200 \pm 220$  lb).
- e. Use a depth micrometer to measure the step length between the bearing surface and the housing surface. Take measurements at several different locations around the housing. Compute the average of the measured dimensions and record the number. Call this Dimension (Y).

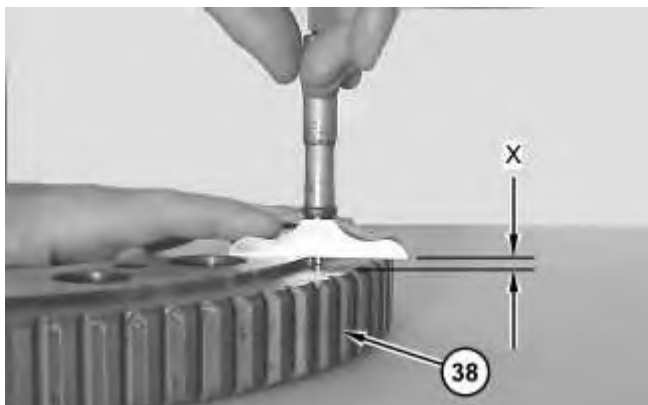

Illustration 4

g01761534

- f. Use a depth micrometer to measure the step length of coupling gear (38). Take measurements at several different locations around coupling gear (38). Compute the average of the measured dimensions and record the number. Call this Dimension (X).
- g. The thickness of the shims is equal to  $(X - Y) \pm 0.05$  mm (0.002 inch).

**Note:** Use no more than two shims. If two shims are required, install the thinner shim next to coupling gear (38).

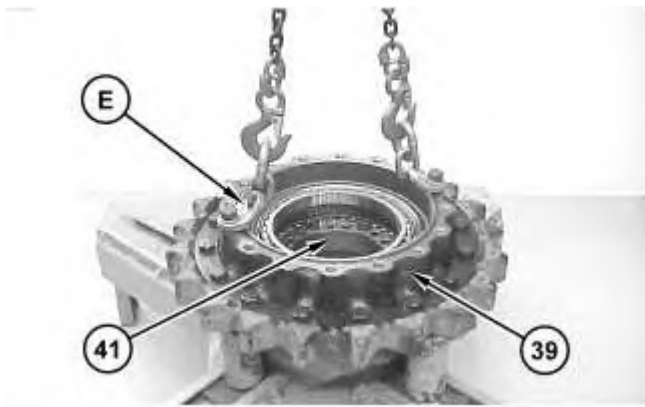

Illustration 5

g01760875

- h. Use Tooling (E) and the suitable lifting device to remove housing (39) from motor housing (41).

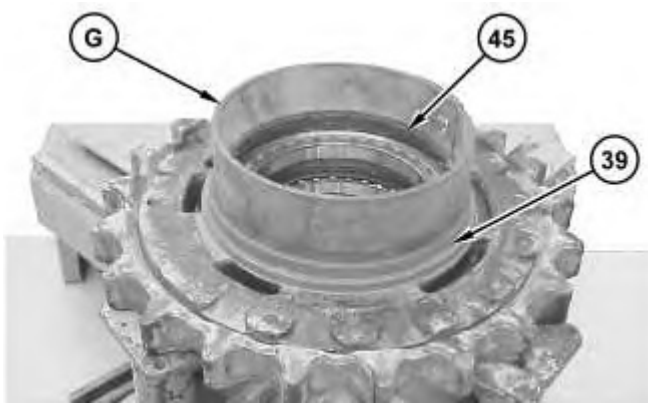

Illustration 6

g01761876

**Note:** The rubber seals and sealing surfaces must be clean and dry. Apply a thin film of clean SAE 30 oil on the contact surfaces of the metal seals prior to assembly.

5. Use Tooling (G) to install Duo-Cone seal (45) in housing (39). Refer to Disassembly and Assembly, "Duo-Cone Conventional Seals - Install".



Illustration 7

g01761954

6. Use Tooling (G) to install Duo-Cone seal (43) in motor housing (41).

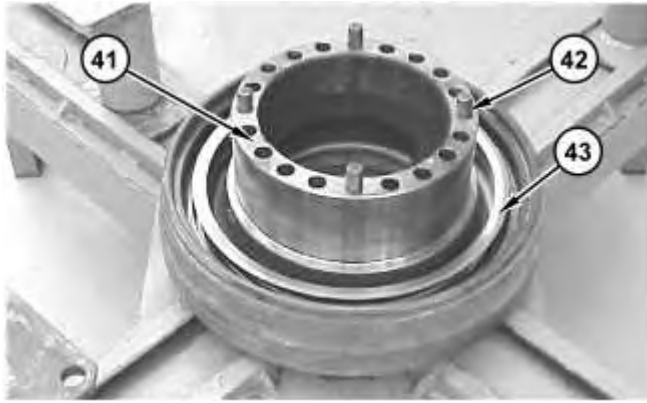

Illustration 8

g01760513

7. Apply Tooling (H) to the surfaces that contact dowel pins (42).
8. Install dowel pins (42).

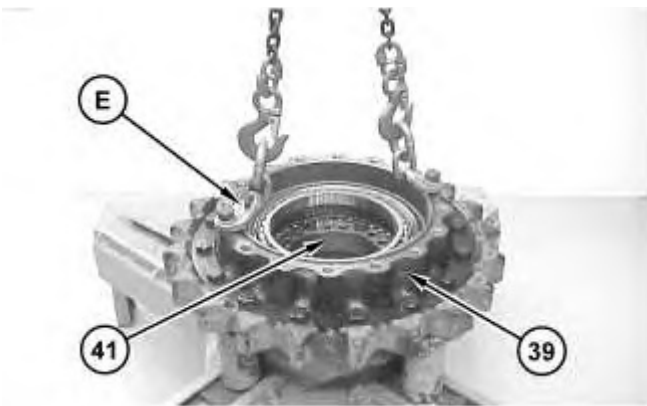

Illustration 9

g01760875

**Note:** Do not damage the Duo-Cone seals in the housing or in motor housing (41) during the assembly of the two components. After installation of the housing on motor housing (41), there will be a small gap between the components. The gap is caused by the Duo-Cone seals. This gap will be eliminated during installation of coupling gear (26) (not shown).

9. Attach Tooling (E) and a suitable lifting device to housing (39). The combined weight of housing (39) and the final drive sprocket is approximately 82 kg (180 lb).
  10. Install housing (39) on motor housing (41).
-

Thank you so much for reading.  
Please click the “Buy Now!”  
button below to download the  
complete manual.



After you pay.

You can download the most  
perfect and complete manual in  
the world immediately.

Our support email:

[ebooklibonline@outlook.com](mailto:ebooklibonline@outlook.com)