

Product: WHEEL TRACTOR

Model: 623H WHEEL TRACTOR EJD

Configuration: 623H Wheel Tractor Scraper EJD00001-UP (MACHINE) POWERED BY C13 Engine

Disassembly and Assembly 621H, 623H and 627H Wheel Tractor-Scrapers Machine Systems

Media Number -KENR9489-02

Publication Date -01/07/2016

Date Updated -07/07/2016

i04500269

Elevator Speed Reducer - Disassemble

SMCS - 6236-015

S/N - EJD1-UP

Disassembly Procedure

Table 1

Required Tools			
Tool	Part Number	Part Description	Qty
A	1P-2420	Transmission Stand	1
B	1P-1863	Retaining Ring Pliers	1
C	138-7575	Link Bracket	3
D	1P-0520	Driver Group	1
E	1P-0520	Driver Group	1
	8B-7548	Puller Assembly	1
	8H-0684	Ratchet	1
	8B-7551	Puller Assembly	1
F	4B-3586	1/2 in 13 NC Forcing Bolt	2
G	138-75754	Link Bracket	2

Start By:

- A. Disassemble the elevator drive.
-



Illustration 1

g00496940

1. Attach the elevator speed reducer to Tooling (A), as shown. Place an alignment mark on the speed reducer for assembly purposes.

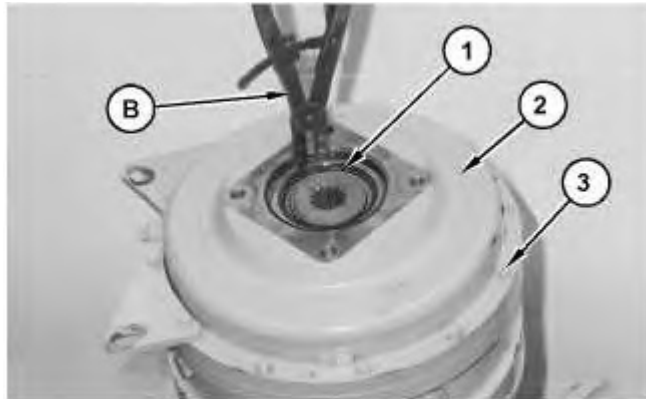
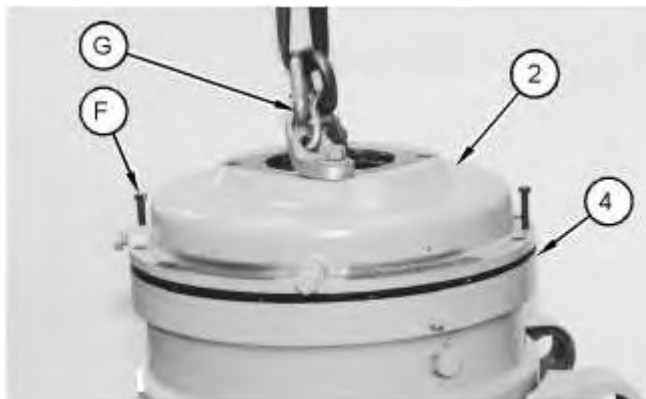

Illustration 2

g01079336

2. Use Tooling (B) to remove retaining ring (1) from flywheel housing (2). Remove bolts (3) from flywheel housing (2) .



3. Attach Tooling (G) and a suitable lifting device onto flywheel housing (2). Use Tooling (F) to loosen flywheel housing (2) from end plate (4). Remove flywheel housing (2) from end plate (4). The weight of flywheel housing (2) is approximately 32 kg (71 lb).

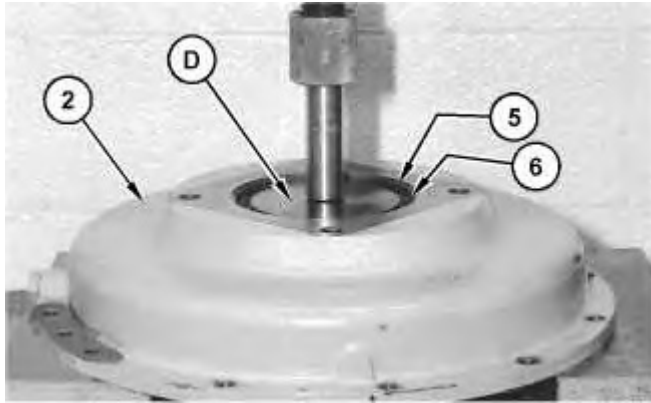

Illustration 4

4. Use Tooling (D) and a suitable press to remove roller bearing (5) (not shown) and lip seal (6) (not shown) from flywheel housing (2) .



Illustration 5

5. Attach Tooling (C) and a suitable lifting device onto flywheel (7). Remove flywheel (7) from end plate (4). The weight of flywheel (7) is approximately 12 kg (26 lb).
-

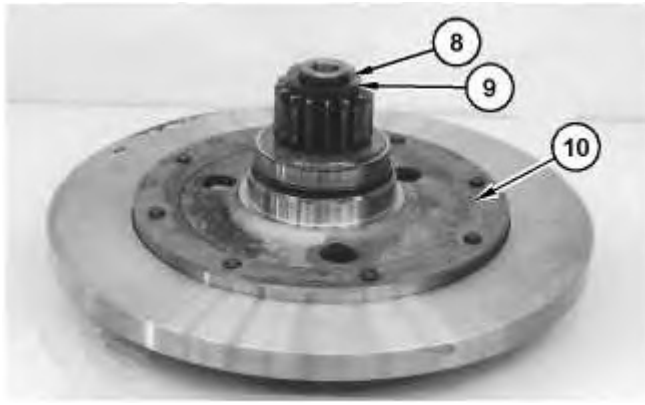

Illustration 6

g01079338

6. Remove retaining ring (8) and thrust disc (9) from hub (10) .

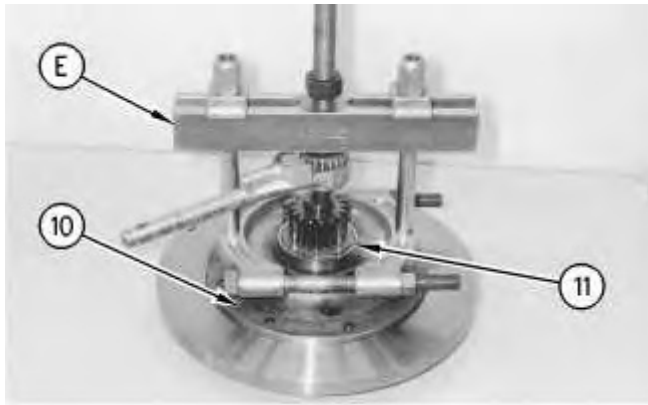

Illustration 7

g00800112

7. Use Tooling (E) to remove bearing inner race (11) from hub (10). Repeat the procedure for the other side of hub (10) .

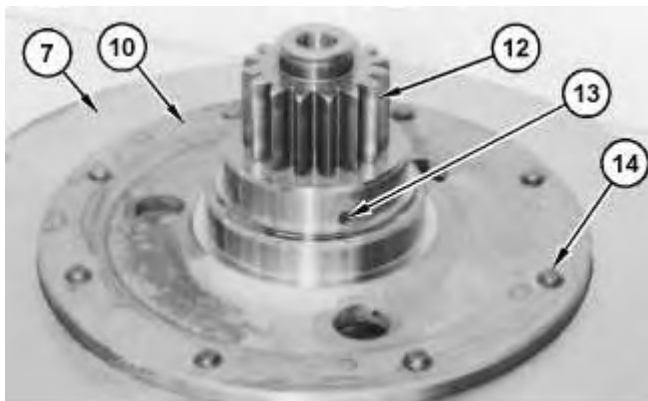

Illustration 8

g01079339

8. Drive pin (13) into gear (12). Remove gear (12) from hub (10). Remove pin (13) from gear (12). Bend the locking tabs away from bolts (14). Remove bolts (14) and the locking tabs from flywheel (7). Remove hub (10) from flywheel (7) .



Illustration 9

g00848811

9. Attach Tooling (C) and a suitable lifting device onto end plate (4). Remove end plate (4) from the ring gear. The weight of end plate (4) is approximately 19 kg (42 lb).

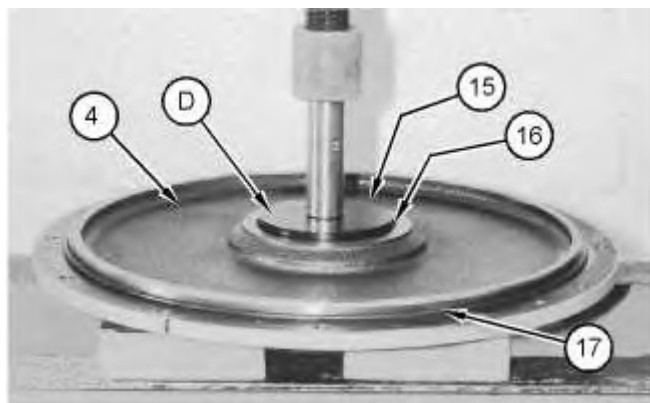

Illustration 10

g01079340

10. Remove O-ring seal (17) from end plate (4). Use Tooling (D) and a suitable press to remove roller bearing (15) (not shown) and lip seal (16) (not shown) from end plate (4) .
-

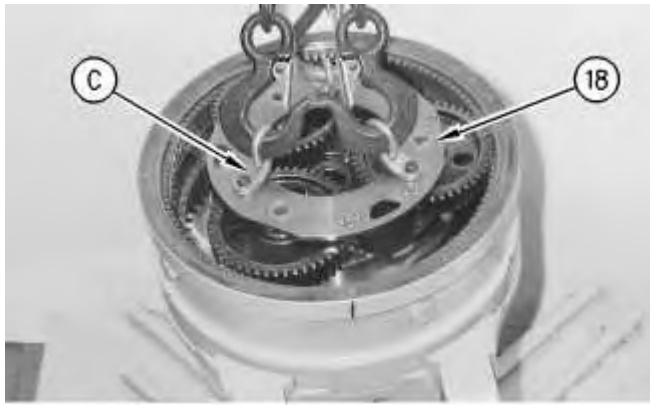

Illustration 11

g00848814

11. Attach Tooling (C) and a suitable lifting device onto carrier assembly (18). Remove carrier assembly (18) from the ring gear. The weight of carrier assembly (18) is approximately 30 kg (66 lb).

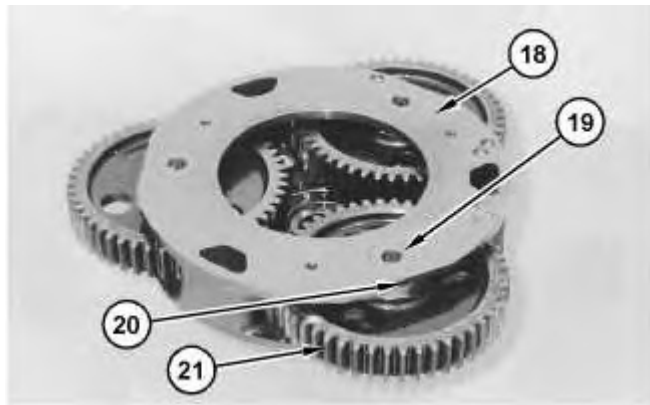
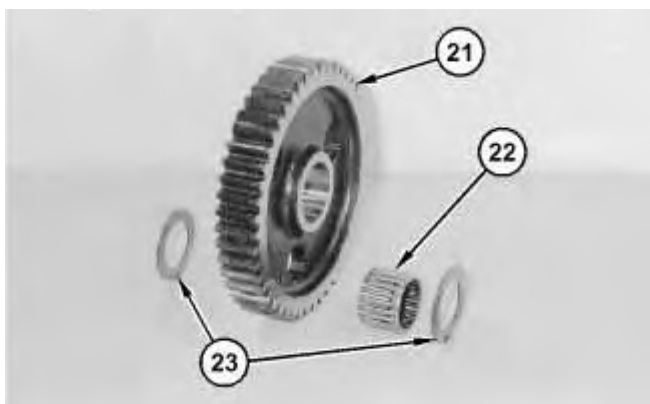

Illustration 12

g01079341

12. Drive spring pin (20) into shaft (19). Remove shaft (19) from carrier assembly (18). Remove spring pin (20) from shaft (19). Remove gear (21) from carrier assembly (18). Repeat the procedure for the other two gears.



13. Remove washers (23) and bearing (22) from gear (21). Repeat the procedure for the other two gears.

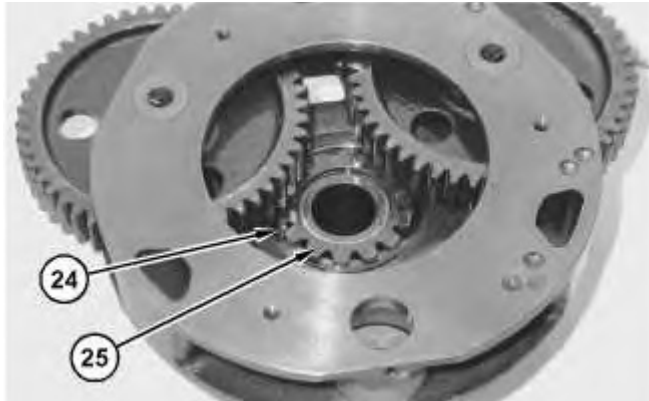

Illustration 14

14. Remove retaining ring (24) and sun gear (25) from the carrier assembly.



Illustration 15

15. Attach Tooling (C) and a suitable lifting device onto carrier assembly (26). Remove carrier assembly (26) from the ring gear. The weight of carrier assembly (26) is approximately 62 kg (137 lb).
-

Thank you so much for reading.
Please click the “Buy Now!”
button below to download the
complete manual.



After you pay.

You can download the most
perfect and complete manual in
the world immediately.

Our support email:

ebooklibonline@outlook.com