

Product: WHEEL LOADER

Model: 980K HLG WHEEL LOADER NEP

Configuration: 980K Wheel Loader High Lift Grapple NEP00001-UP (MACHINE) POWERED BY C13 Engine

## Disassembly and Assembly 980K Wheel Loader Power Train

Media Number -KENR6447-03

Publication Date -01/08/2012

Date Updated -21/08/2012

i04400923

# Torque Converter - Disassemble - Heavy Duty

SMCS - 3101-015

## Disassembly Procedure

Table 1

Required Tools			
Tool	Part Number	Part Description	Qty
A	138-7573	Link Bracket	1
B	8B-7548	Push-Puller	1
	8B-7550	Leg	2
	8H-0684	Ratchet Wrench	1
	8B-7560	Step Plate	1
	8H-0663	Bearing Puller Attachment	1
C	8B-7548	Push-Puller	1
	8H-0684	Ratchet Wrench	1
	8B-7549	Leg	2
	5P-4808	Cap	2
	8B-7554	Bearing Cup Puller Attachment	1
D	5F-7343	Bearing Puller Attachment	1
	1P-0520	Driver Group	1
E	1P-0520	Driver Group	1

**Start By:**

- a. Separate the torque converter from the transmission and from the output transfer gears. Refer to Disassembly and Assembly, "Torque Converter from Transmission, Output Transfer Gears - Separate" for the machine that is being serviced.

1. Place the torque converter housing assembly on wood blocks.

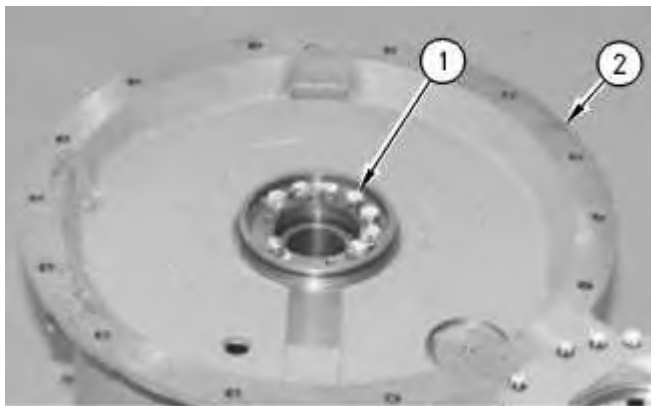

Illustration 1

g00503225

2. Remove eight bolts (1) and the washers from torque converter housing assembly (2).

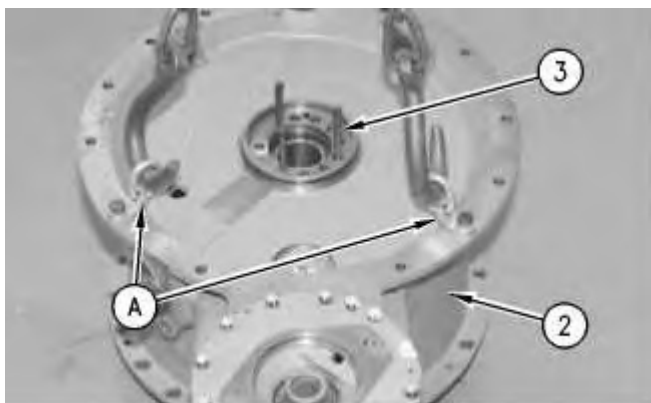

Illustration 2

g00503286

3. Install Tooling (A) to torque converter housing assembly (2), as shown. Attach a hoist and suitable lifting chains to Tooling (A).
  4. Use three 3/8" - 16 NC forcing screws (3) to loosen housing assembly (2) from the torque converter.
  5. Use the hoist to remove housing assembly (2) from the torque converter. The weight of housing assembly (2) is 120 kg (265 lb).
-

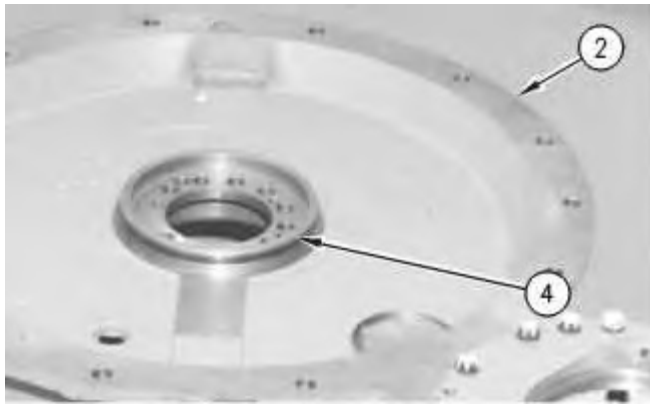

Illustration 3

g00503287

6. Remove O-ring seal (4) from torque converter housing assembly (2).

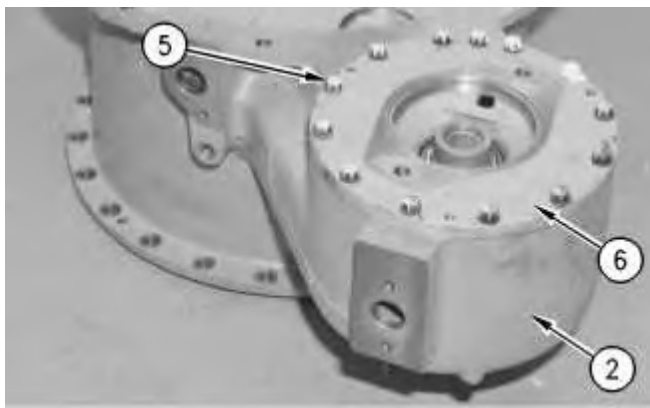

Illustration 4

g00503288

7. Remove thirteen bolts (5) and the washers from pump adapter (6) and torque converter housing assembly (2).

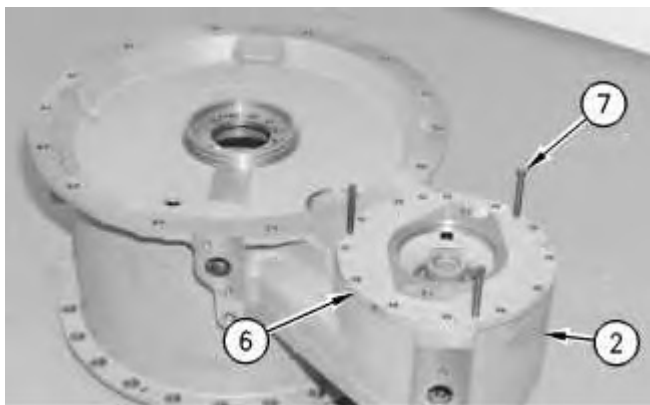

Illustration 5

g00503289

8. Use three 3/8" - 16 NC forcing screws (7) to remove pump adapter (6) from torque converter housing assembly (2).

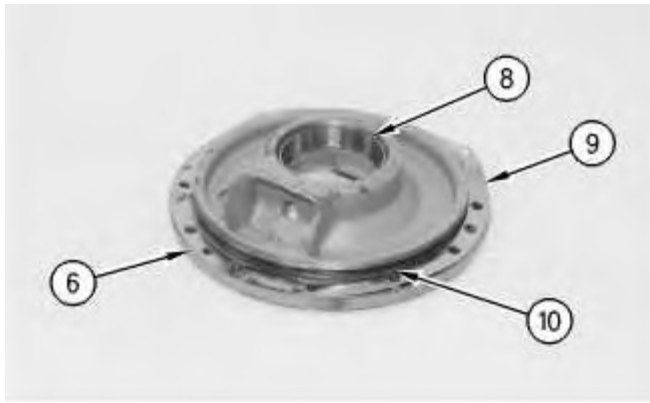

Illustration 6

g00503291

9. Remove bearing cup (8), O-ring seal (10) and shims (9) from pump adapter (6).



Illustration 7

g00503292

10. Remove pump drive gear (11) from torque converter housing assembly (2).

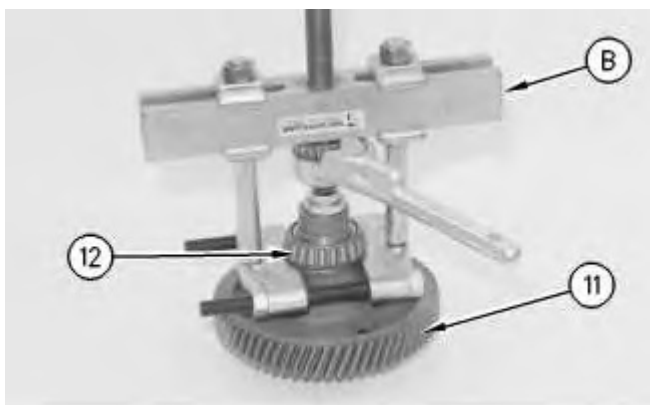

Illustration 8

g00503294

11. Use Tooling (B) to remove bearing cones (12) from each side to pump drive gear (11).



Illustration 9

g00503296

12. Use Tooling (C) to remove bearing cup (13) from torque converter housing assembly (2).

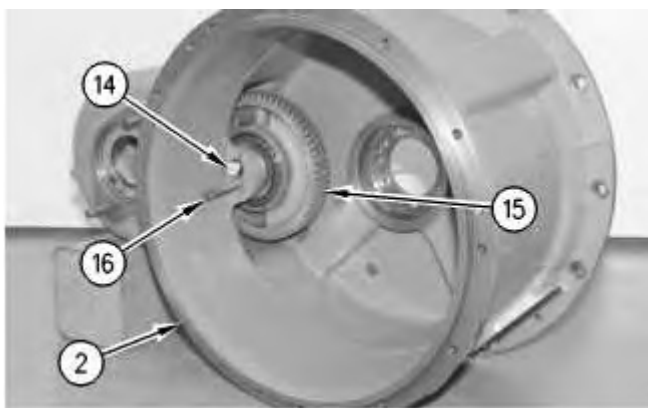

Illustration 10

g00503297

13. Remove bolt (14) and the washer from torque converter housing assembly (2).
14. Use 3/8" - 16 NC forcing screw (16) to push the shaft assembly out of torque converter housing assembly (2).
15. Remove idler gear (15) from torque converter housing assembly (2).

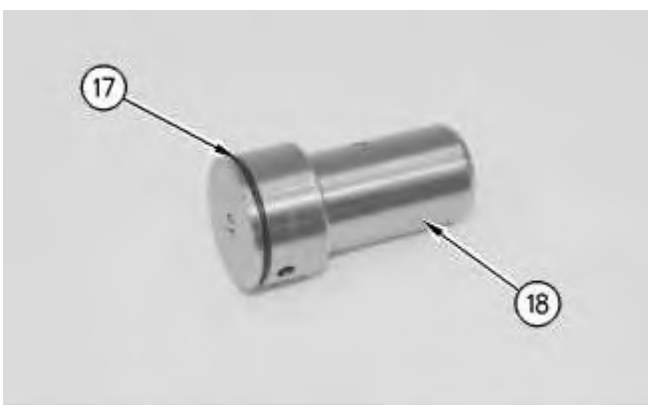

Illustration 11

g00503298

16. Remove O-ring seal (17) from shaft assembly (18).

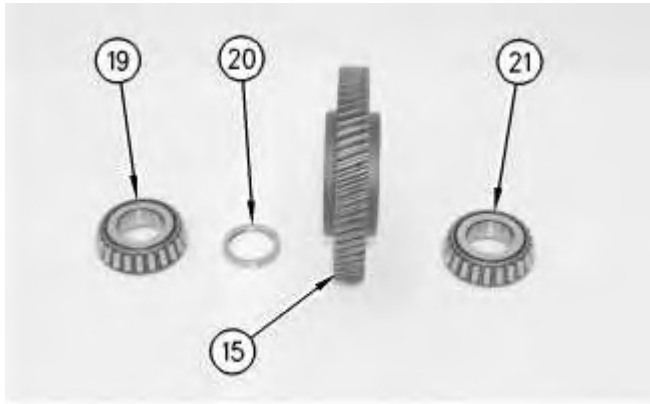

Illustration 12

g00503299

17. Remove bearing cone (19), bearing cone spacer (20) and bearing cone (21) from idler gear (15).

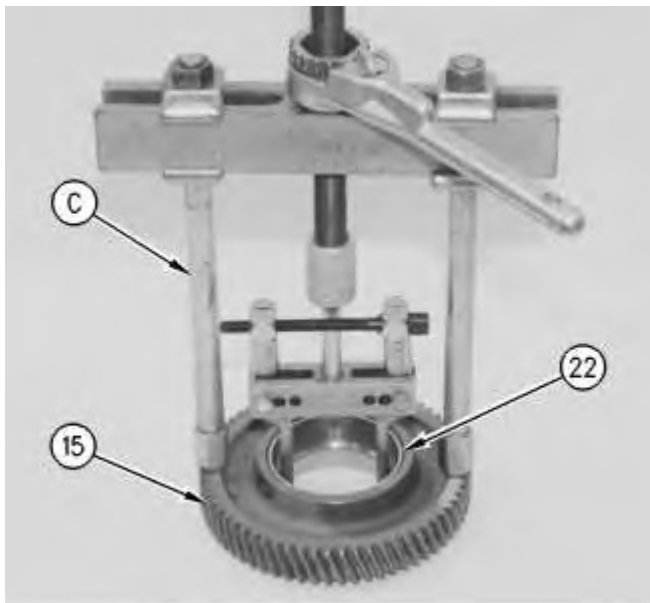

Illustration 13

g00503301

18. Use Tooling (C) to remove bearing cup (22) from idler gear (15).

---



Illustration 14

g00503302

19. Remove bearing cup spacer (23) from idler gear (15).

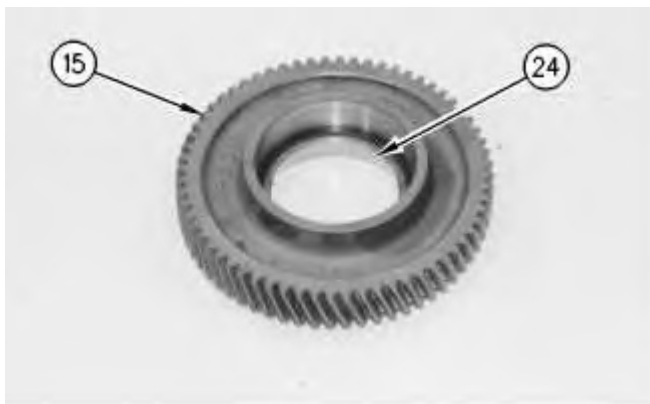

Illustration 15

g00503308

20. Remove retaining ring (24) from idler gear (15).



Illustration 16

g00503309

Thank you so much for reading.  
Please click the “Buy Now!”  
button below to download the  
complete manual.



After you pay.

You can download the most  
perfect and complete manual in  
the world immediately.

Our support email:

[ebooklibonline@outlook.com](mailto:ebooklibonline@outlook.com)