



Service Repair Manual

Models

980M Wheel Loader

Product: WHEEL LOADER

Model: 980M WHEEL LOADER WW3

Configuration: 980M Wheel Loader WW300001-UP (MACHINE) POWERED BY C13 Engine

Disassembly and Assembly 980M T4 and 982M T4 Wheel Loader Power Train

Media Number -M0075587-02

Publication Date -01/08/2012

Date Updated -17/07/2018

i06838485

Torque Converter - Assemble - Lock Up Clutch with Freewheel Stator

SMCS - 3101-016

Assembly Procedure

Table 1

Required Tools			
Tool	Part Number	Part Description	Qty
A	439-3938	Link Bracket	3
G	8T-5096	Dial Indicator Test Group	1
	5P-2390	Gauge Tool Group	1
H	1P-0520	Driver Group	1
J	-	Guide Stud (3/8 - 16 by 8 in)	2
K	-	Guide Stud (1/2 - 13 by 3 in)	3
L	2P-8312	Retaining Ring Pliers	1



Illustration 1

g02752296

1. Install seals (64).



Illustration 2

g02735387

2. Install adapter (63), hub (62), and bolts (61) onto impeller (54). Tighten bolts (61) to a torque of $105 \pm 14 \text{ N}\cdot\text{m}$ ($77 \pm 10 \text{ lb ft}$).



Illustration 3

g02735380

3. Install bearing (60).

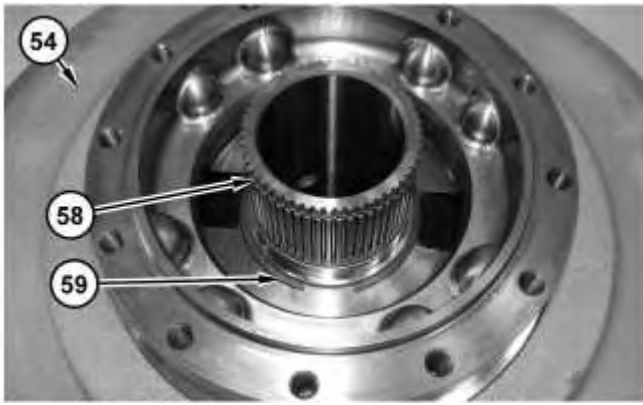

Illustration 4

g02735374

4. Install carrier assembly (58) and retaining ring (59) onto impeller (54).



Illustration 5

g02744677

5. Raise the temperature of bearing (57). Install bearing (57) onto hub (55).
6. Install seal ring (56).



Illustration 6

g02734776



Illustration 7

g02735333

7. Install hub (55) and retaining ring (56) onto impeller (54).

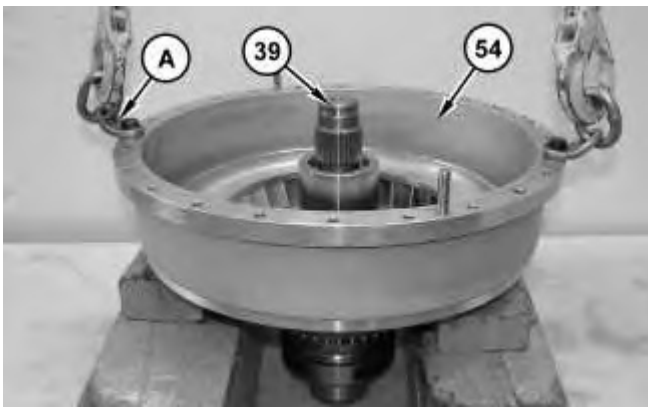

Illustration 8

g02732255

8. Attach Tooling (A) and a suitable lifting device to impeller (54). The weight of impeller (54) is approximately 27 kg (60 lb).
9. Position impeller (54) onto shaft assembly (39).



Illustration 9

g02731806

10. Install retaining ring (53) (not shown) and plate (52) onto stator (46).

Thank you so much for reading.
Please click the “Buy Now!”
button below to download the
complete manual.



After you pay.

You can download the most
perfect and complete manual in
the world immediately.

Our support email:

ebooklibonline@outlook.com