



# Service Repair Manual

## **Models**

# 988H Wheel Loader

---

Product: WHEEL LOADER

Model: 988H WHEEL LOADER BXY

Configuration: 988H Wheel Loader BXY00001-UP (MACHINE) POWERED BY C18 Engine

## Disassembly and Assembly 988H and 988K Wheel Loaders Power Train

Media Number -REN6206-05

Publication Date -01/07/2015

Date Updated -10/07/2015

i06677468

## Torque Converter - Assemble

SMCS - 3101-016

S/N - A7A1-UP

S/N - BXY1-UP

## Assembly Procedure

Table 1

Required Tools			
Tool	Part Number	Part Description	Qty
A	138-7573	Link Bracket	1
	138-7575	Link Bracket	2
B	138-7575	Link Bracket	3
H	1P-0520	Driver Gp	1
J	8T-5096	Dial Indicator Gp	1
J	4C-4030	Loctite	-

---

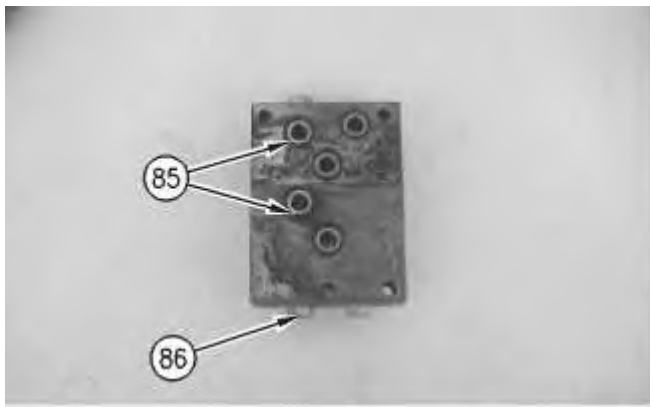

Illustration 1

g00663671

1. Install O-rings (85) and plugs (86).

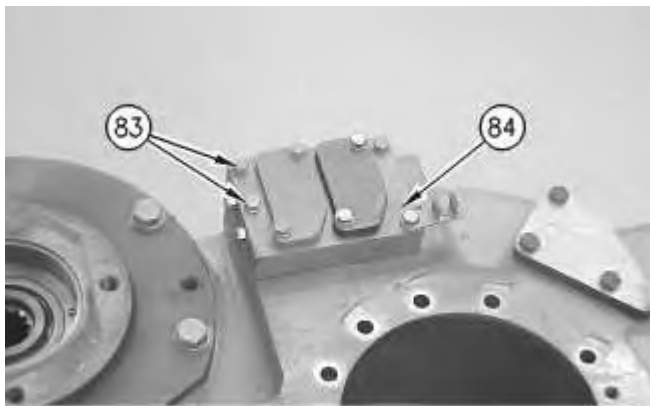

Illustration 2

g00663628

2. Install block (84) and bolts (83).

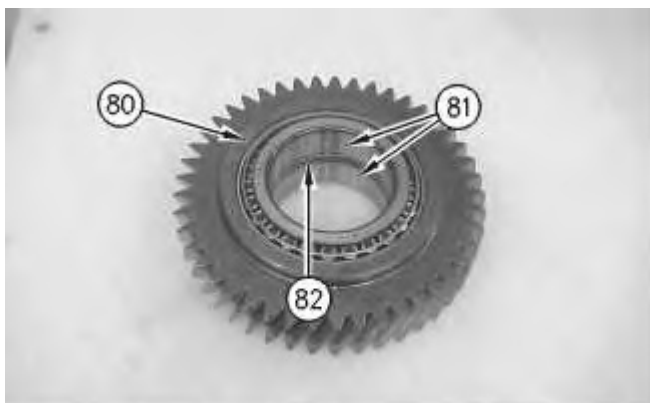

Illustration 3

g00663627

3. Install bearing assemblies (81) and ring (82) into idler gear assembly (80).



Illustration 4

g00663626

4. Install idler gear assembly (80).

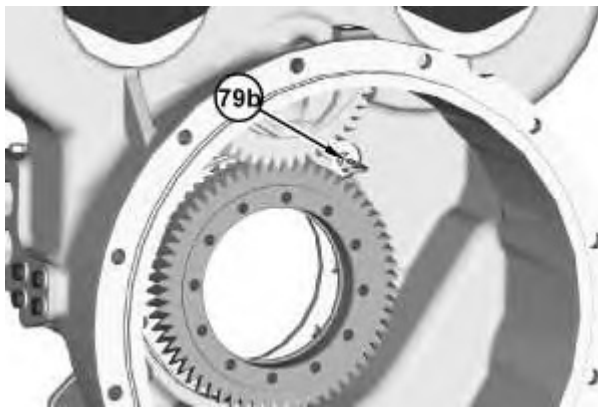

Illustration 5

g03410201

If equipped with this style lube adapter.



Illustration 6

g03410188

If equipped with this style lube adapter.

5. Install lube adapter (79b), (79a). Use Tooling (J) on threads of (79b) and (79a).

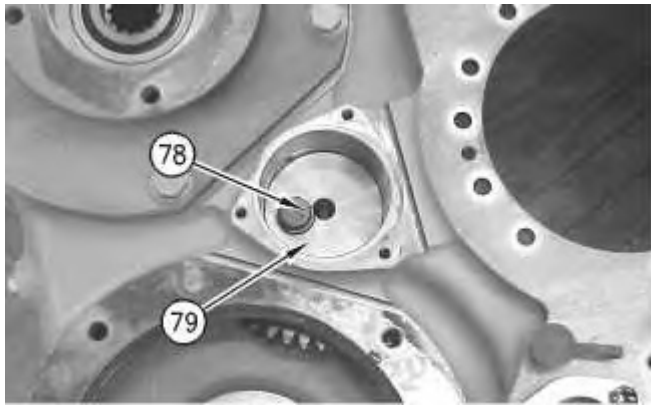

Illustration 7

g00663624

6. Install idler gear shaft (79). Install bolt (78) and the washer.

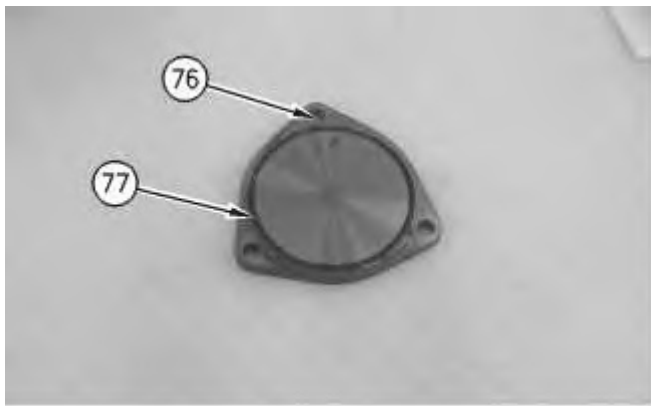

Illustration 8

g00663623

7. Install O-ring seal (77) onto cover (76).

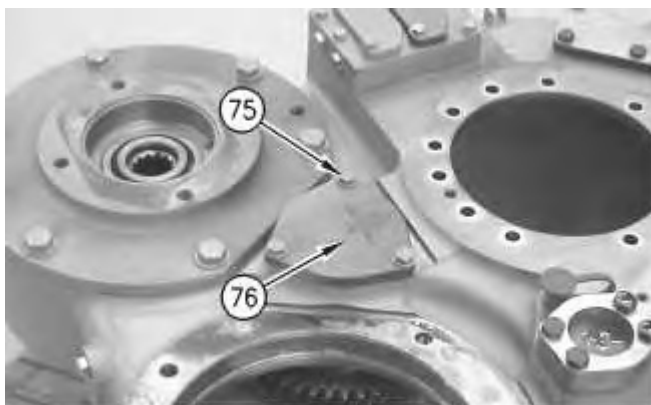

Illustration 9

g00663622

8. Install cover (76) and three bolts (75).

Thank you so much for reading.  
Please click the “Buy Now!”  
button below to download the  
complete manual.



After you pay.

You can download the most  
perfect and complete manual in  
the world immediately.

Our support email:

[ebooklibonline@outlook.com](mailto:ebooklibonline@outlook.com)