



Service Repair Manual

Models

C11 Industrial Engine

Product: INDUSTRIAL ENGINE
Model: C11 INDUSTRIAL ENGINE GLS
Configuration: C11 Industrial Engine GLS00001-UP

Disassembly and Assembly C11 and C13 Industrial Engines

Media Number -REN8632-06

Publication Date -01/10/2018

Date Updated -24/10/2018

i02247841

Inlet and Exhaust Valves - Remove and Install

SMCS - 1105-010

Removal Procedure

Table 1

Required Tools			
Tool	Part Number	Part Description	Qty
A	5S-1330	Valve Spring Compressor	1

Start By:

- a. Remove the cylinder head. Refer to Disassembly and Assembly, "Cylinder Head - Remove".

NOTICE

Keep all parts clean from contaminants.

Contaminants may cause rapid wear and shortened component life.

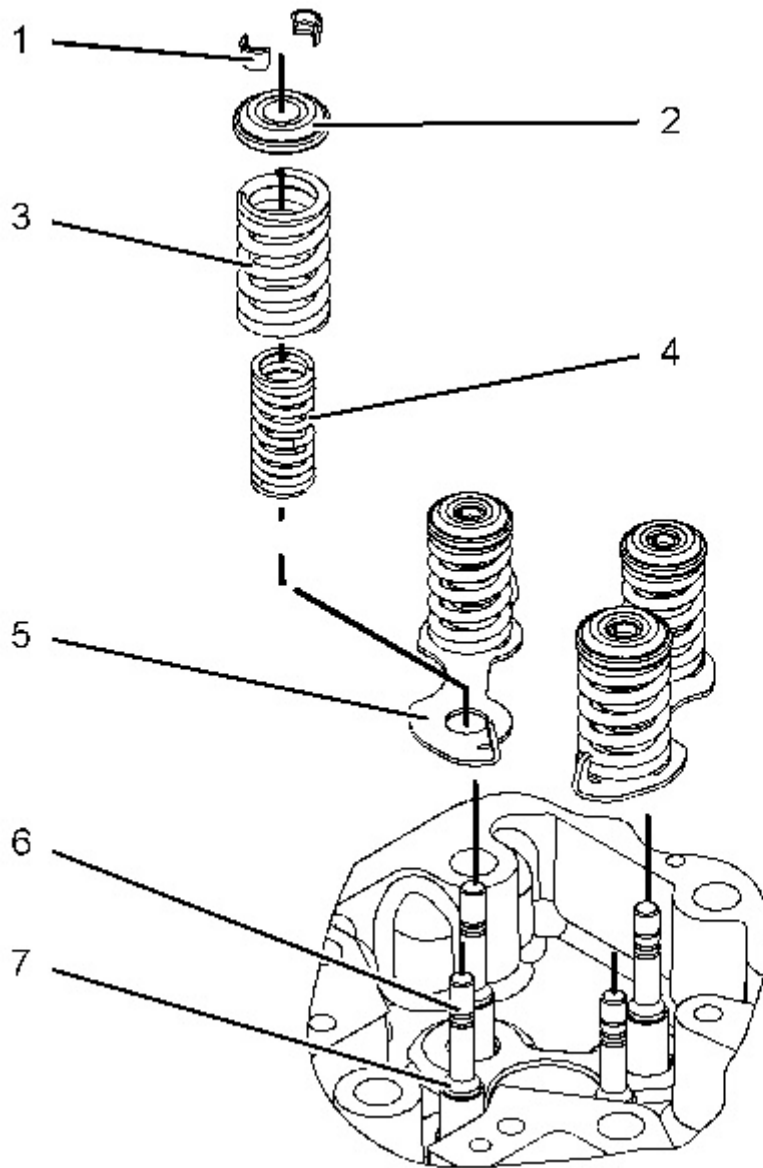

Illustration 1

g01131781

! WARNING

Personal injury can result from being struck by parts propelled by a released spring force.

Make sure to wear all necessary protective equipment.

Follow the recommended procedure and use all recommended tooling to release the spring force.

1. Use Tooling (A) to remove retainer locks (1).
2. Remove valve rotators (2).

3. Remove valve springs (3) and valve springs (4).
4. Remove base (5).
5. Remove valves (6) from the cylinder head.
6. Remove valve seals (7).

Installation Procedure

Table 2

Required Tools			
Tool	Part Number	Part Description	Qty
A	5S-1330	Valve Spring Compressor	1

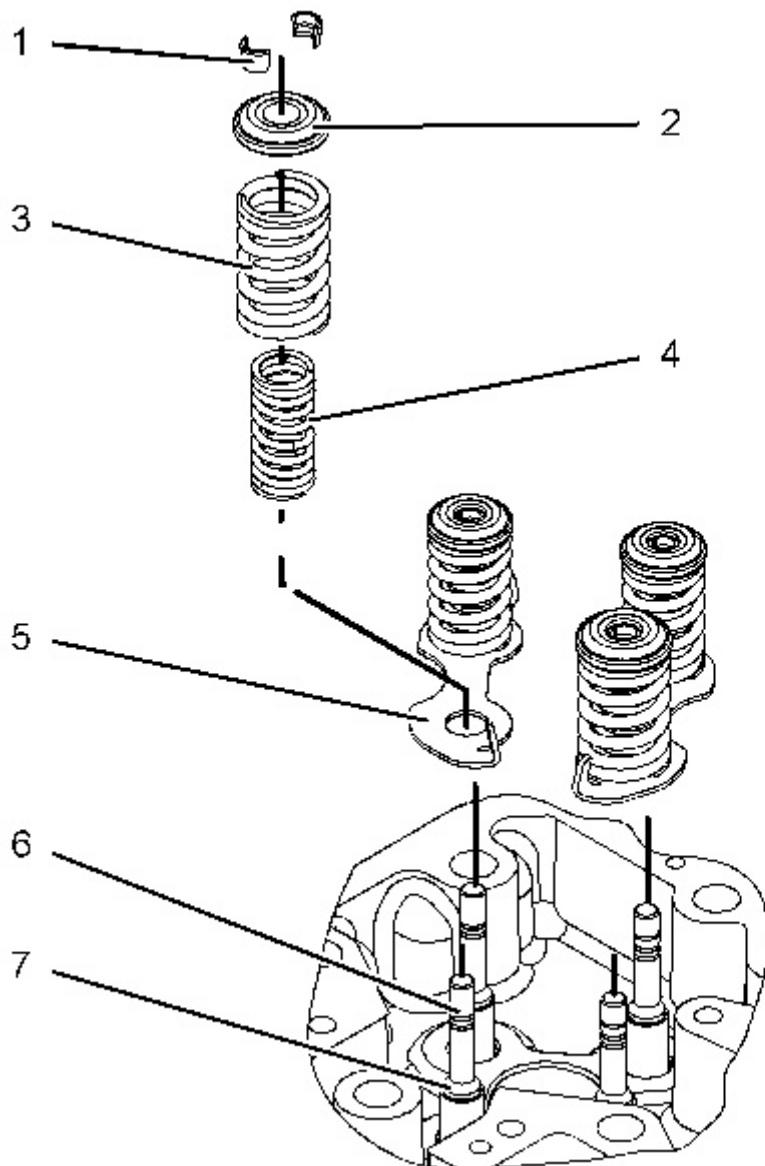



The valve keepers can be thrown from the valve when the valve spring compressor is released. Ensure that the valve keepers are properly installed on the valve stem. To help prevent personal injury, keep away from the front of the valve keepers and valve springs during the installation of the valves.

Note: A small amount of grease can be used to hold the retainer locks in position during installation.

1. Lubricate valves (6) with clean engine oil. Install the valves in the cylinder head assembly.
2. Install valve seals (7).
3. Install base (5).
4. Install valve springs (3) and valve springs (4).
5. Install valve rotators (2).
6. Use Tooling (A) to install retainer locks (1).

End By:

- a. Install the cylinder head. Refer to Disassembly and Assembly, "Cylinder Head - Install".
-

Thank you so much for reading.
Please click the “Buy Now!”
button below to download the
complete manual.



After you pay.

You can download the most
perfect and complete manual in
the world immediately.

Our support email:

ebooklibonline@outlook.com