



# Service Repair Manual

## **Models**

# C18 Industrial Engine

---

Product: INDUSTRIAL ENGINE  
Model: C18 INDUSTRIAL ENGINE EJG  
Configuration: C18 Industrial Engine EJG00001-UP

## **Disassembly and Assembly C15 and C18 Industrial Engines**

Media Number -REN8630-07

Publication Date -01/11/2017

Date Updated -15/11/2017

i02536739

# **Fuel Priming Pump - Remove and Install**

SMCS - 1258-010

## **Removal Procedure**

---

### **NOTICE**

**Care must be taken to ensure that fluids are contained during performance of inspection, maintenance, testing, adjusting, and repair of the product. Be prepared to collect the fluid with suitable containers before opening any compartment or disassembling any component containing fluids.**

**Refer to Special Publication, NENG2500, "Dealer Service Tool Catalog" for tools and supplies suitable to collect and contain fluids on Cat products.**

**Dispose of all fluids according to local regulations and mandates.**

---

---

### **NOTICE**

**Keep all parts clean from contaminants.**

**Contaminants may cause rapid wear and shortened component life.**

---

1. Turn the fuel supply to the "OFF" position.
-

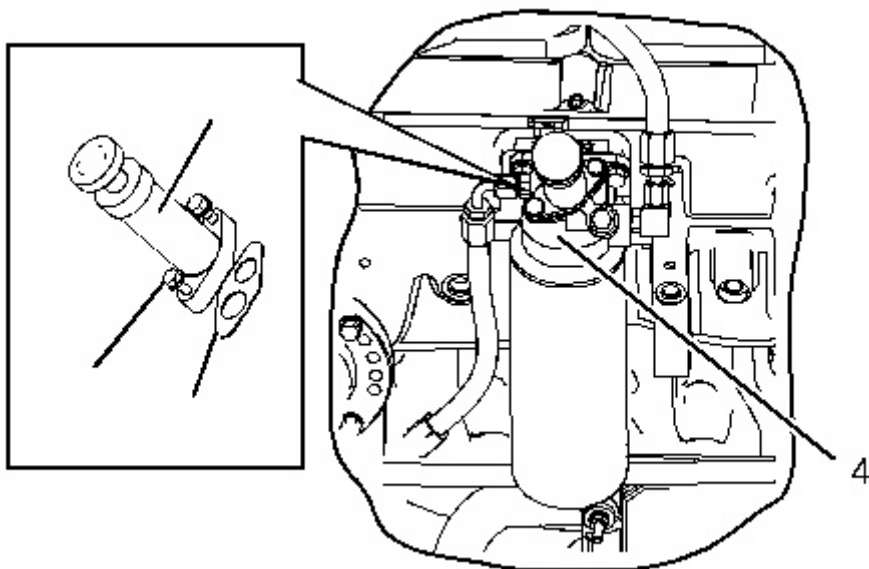

---

Illustration 1

g01049296

2. Remove bolts (2). Remove fuel priming pump assembly (1) from fuel filter base (4).
3. Remove gasket (3) from the fuel priming pump assembly and the fuel filter base.

## Installation Procedure

---

### NOTICE

**Keep all parts clean from contaminants.**

**Contaminants may cause rapid wear and shortened component life.**

---

---

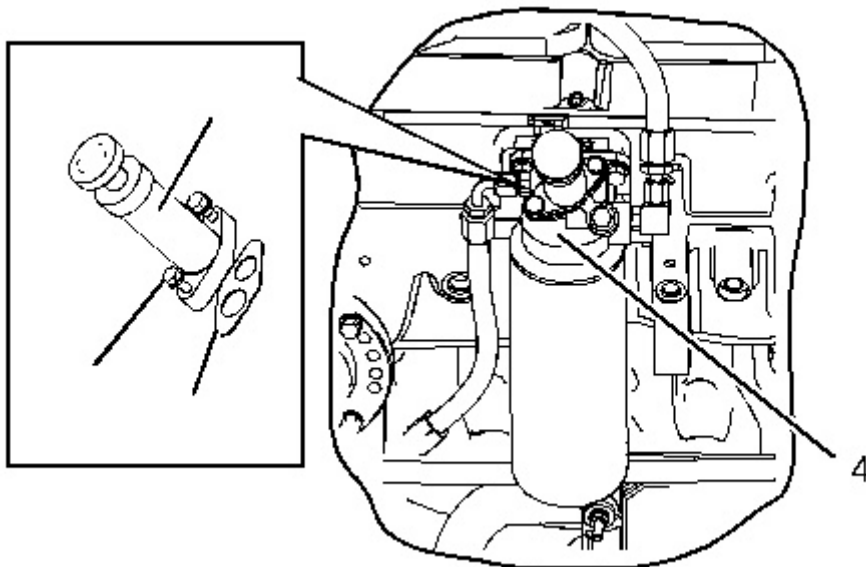

---

Illustration 2

g01049296

1. Position gasket (3) on fuel filter base (4).
2. Position fuel priming pump assembly (1) on the fuel filter base and install bolts (2).
3. Turn the fuel supply to the “ON” position.
4. Remove the air from the system. Refer to Testing and Adjusting, "Fuel System - Prime".

Product: INDUSTRIAL ENGINE  
Model: C18 INDUSTRIAL ENGINE EJG  
Configuration: C18 Industrial Engine EJG00001-UP

## Disassembly and Assembly C15 and C18 Industrial Engines

Media Number -REN8630-07

Publication Date -01/11/2017

Date Updated -15/11/2017

i02163698

## Fuel Filter Base - Remove

SMCS - 1262-011

### Removal Procedure

Table 1

Required Tools			
Tool	Part Number	Part Description	Qty
A	185-3630	Strap Wrench	1

---

### NOTICE

Care must be taken to ensure that fluids are contained during performance of inspection, maintenance, testing, adjusting and repair of the product. Be prepared to collect the fluid with suitable containers before opening any compartment or disassembling any component containing fluids.

Refer to Special Publication, NENG2500, "Caterpillar Dealer Service Tool Catalog" for tools and supplies suitable to collect and contain fluids on Caterpillar products.

Dispose of all fluids according to local regulations and mandates.

---

### NOTICE

Keep all parts clean from contaminants.

Thank you so much for reading.  
Please click the “Buy Now!”  
button below to download the  
complete manual.



After you pay.

You can download the most  
perfect and complete manual in  
the world immediately.

Our support email:

[ebooklibonline@outlook.com](mailto:ebooklibonline@outlook.com)