



# Service Repair Manual

## **Models**

# C27 Locomotive Engine

---

Product: INDUSTRIAL ENGINE  
Model: C27 INDUSTRIAL ENGINE WJC  
Configuration: C27 Locomotive Engine WJC00001-UP

## Disassembly and Assembly C27 and C32 Engines

Media Number -M0074364-00

Publication Date -01/08/2015

Date Updated -13/09/2016

i02986920

# Crankshaft Front Seal - Install

SMCS - 1160-012

## Installation Procedure

Table 1

Required Tools			
Tool	Part Number	Part Description	Qty
E	5P-1733	Seal Locator	1
	5P-1737	Bolt	3
	9S-8858	Nut (Seal Installer)	1
	6V-6142	Seal Installer	1

---

### NOTICE

**Keep all parts clean from contaminants.**

**Contaminants may cause rapid wear and shortened component life.**

---

1. Clean the outside diameter of the crankshaft.
-

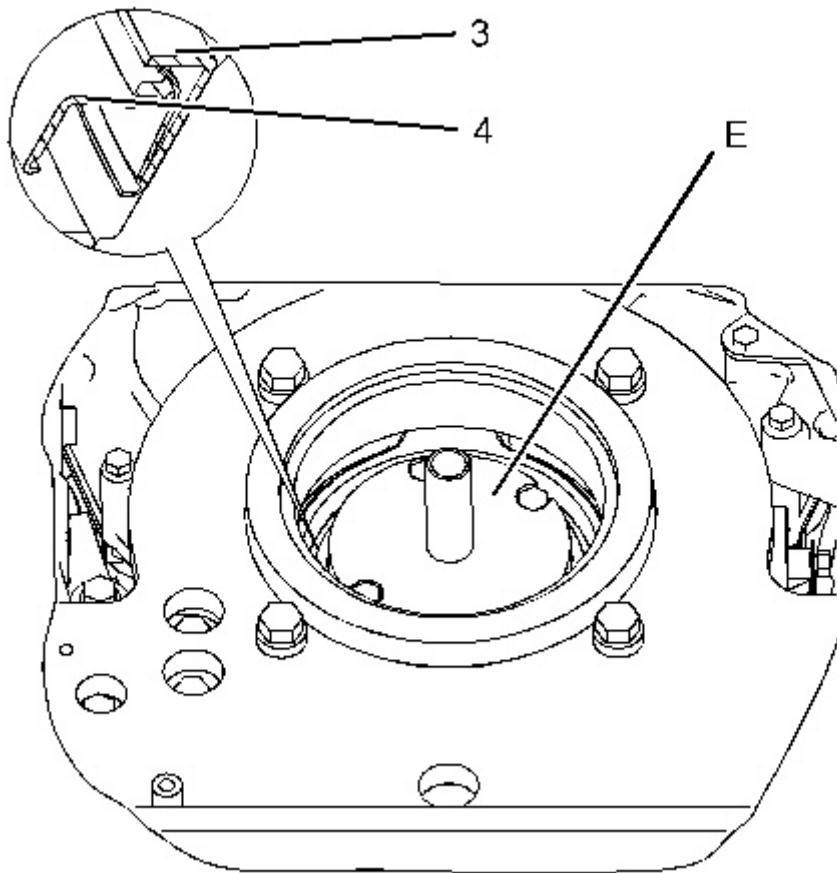

---

Illustration 1

g01513455

2. Use Tooling (E) to install crankshaft front seal (4) and crankshaft wear sleeve (3) as a unit.

**Note:** Install the crankshaft front seal with the arrow that shows the direction of crankshaft rotation toward the front of the engine.

---

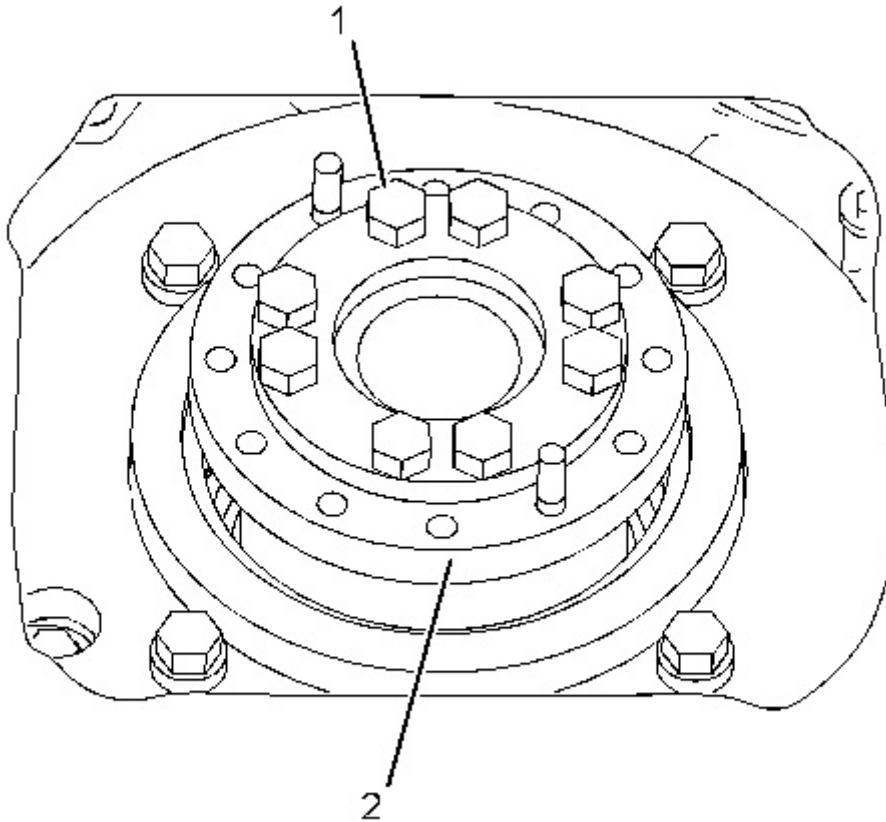

---

Illustration 2

g01098057

3. Install adapter (2) and bolts (1).

**End By:**

- a. Install the crankshaft vibration damper and pulley. Refer to Disassembly and Assembly, "Vibration Damper and Pulley - Remove and Install".

Product: INDUSTRIAL ENGINE  
Model: C27 INDUSTRIAL ENGINE WJC  
Configuration: C27 Locomotive Engine WJC00001-UP

## Disassembly and Assembly C27 and C32 Engines

Media Number -M0074364-00

Publication Date -01/08/2015

Date Updated -13/09/2016

i05933887

## Gear Group (Front) - Remove

SMCS - 1206-011

### Removal Procedure

Table 1

Required Tools			
Tool	Part Number	Part Description	Qty
A	8S-2241	Camshaft Bearing Tool Group	1
	6V-4869	Adapter	1
	6V-6174	Plug	1

#### Start By:

- Remove the front housing. Refer to Disassembly and Assembly, "Housing (Front) - Remove".

---

### NOTICE

**Keep all parts clean from contaminants.**

**Contaminants may cause rapid wear and shortened component life.**

---

---

Thank you so much for reading.  
Please click the “Buy Now!”  
button below to download the  
complete manual.



After you pay.

You can download the most  
perfect and complete manual in  
the world immediately.

Our support email:

[ebooklibonline@outlook.com](mailto:ebooklibonline@outlook.com)