

Product: TRACK-TYPE TRACTOR

Model: D6H TRACK-TYPE TRACTOR 3ZF

Configuration: D6H & D6H LGP SERIES II TRACTORS /DIFFERENTIAL STEERING/ 3ZF04000-UP (MACHINE) POWERED BY 3306 ENGINE

Disassembly and Assembly 3304B and 3306B Engines for Caterpillar Built Machines

Media Number -SEN5598-09

Publication Date -01/01/2013

Date Updated -25/01/2013

i01111802

Engine Balancer Shaft - Remove and Install

SMCS - 1220-010-JF

Removal Procedure

Start By:

- A. Remove the front housing cover. Refer to Disassembly and Assembly, "Front Housing Cover - Remove".
- B. Remove the engine oil pump. Refer to Disassembly and Assembly, "Engine Oil Pump - Remove".

NOTICE

Keep all parts clean from contaminants.

Contaminants may cause rapid wear and shortened component life.

NOTICE

Care must be taken to ensure that fluids are contained during performance of inspection, maintenance, testing, adjusting and repair of the product. Be prepared to collect the fluid with suitable containers before opening any compartment or disassembling any component containing fluids.

Refer to Special Publication, NENG2500, "Caterpillar Tools and Shop Products Guide" for tools and supplies suitable to collect and contain fluids on Caterpillar products.

Dispose of all fluids according to local regulations and mandates.

Note: The oil pan plate has been removed for photo purposes only.

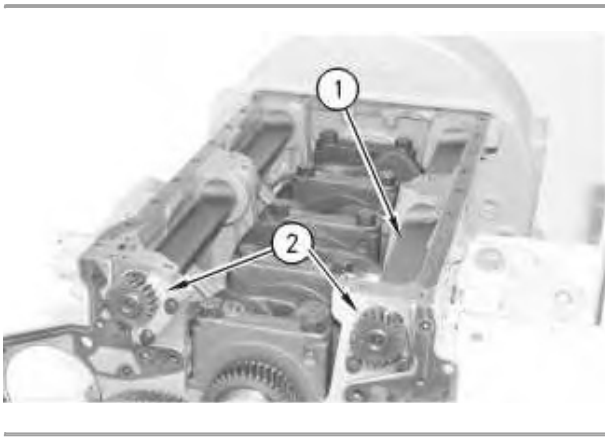

Illustration 1

g00590442

1. Remove plates (2) that hold the balancer shaft in the cylinder block.
2. Remove balancer shafts (1) from the cylinder block.

Installation Procedure

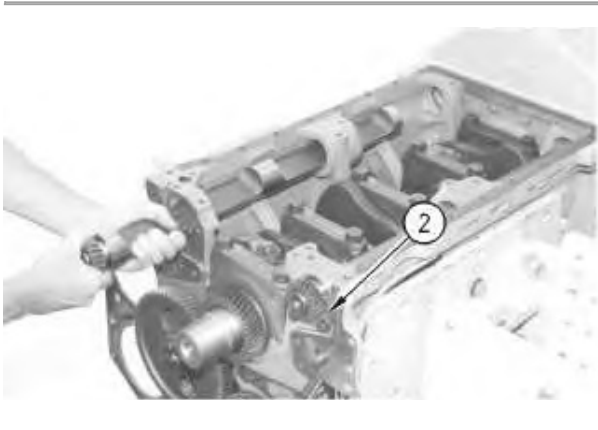

Illustration 2

g00590449

NOTICE

Keep all parts clean from contaminants.

Contaminants may cause rapid wear and shortened component life.

1. Install the balancer shafts in each side of the cylinder block.
2. Install plates (2) and the bolts that hold the balancer shafts in position in the cylinder block.

Note: Ensure that the balancer shafts are in time before the oil pump is installed.

End By:

- a. Install the engine oil pump. Refer to Disassembly and Assembly, "Engine Oil Pump - Install".
 - b. Install the front housing cover. Refer to Disassembly and Assembly, "Front Housing Cover - Install".
-

Product: TRACK-TYPE TRACTOR

Model: D6H TRACK-TYPE TRACTOR 3ZF

Configuration: D6H & D6H LGP SERIES II TRACTORS /DIFFERENTIAL STEERIN/ 3ZF04000-UP (MACHINE) POWERED BY 3306 ENGINE

Disassembly and Assembly 3304B and 3306B Engines for Caterpillar Built Machines

Media Number -SEN5598-09

Publication Date -01/01/2013

Date Updated -25/01/2013

i01135419

Engine Balancer Shaft Bearings - Remove and Install

SMCS - 1220-010-BD

Removal Procedure

Table 1

Required Tools			
Tool	Part Number	Part Description	Qty
A	8S-2241	Camshaft Bearing Tool Group	1
	8H-0684	Ratchet Wrench	1

Start By:

- Remove the engine oil pan. Refer to Disassembly and Assembly, "Engine Oil Pan - Remove".
- Remove the balancer shaft. Refer to Disassembly and Assembly, "Balancer Shaft - Remove".
- Remove the flywheel housing. Refer to Disassembly and Assembly, "Flywheel Housing Remove".

NOTICE

Keep all parts clean from contaminants.

Contaminants may cause rapid wear and shortened component life.

NOTICE

Care must be taken to ensure that fluids are contained during performance of inspection, maintenance, testing, adjusting and repair of the product. Be prepared to collect the fluid with suitable containers before opening any compartment or disassembling any component containing fluids.

Refer to Special Publication, NENG2500, "Caterpillar Tools and Shop Products Guide" for tools and supplies suitable to collect and contain fluids on Caterpillar products.

Dispose of all fluids according to local regulations and mandates.

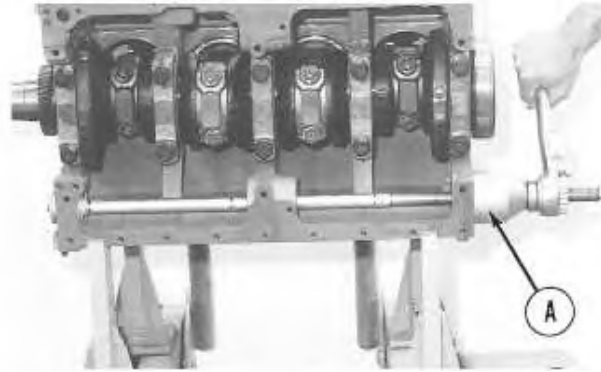

Illustration 1

g00602186

Use Tool (A) to remove the six balancer shaft bearing. Pull the balancer shaft bearings toward the flywheel end of the engine.

Installation Procedure

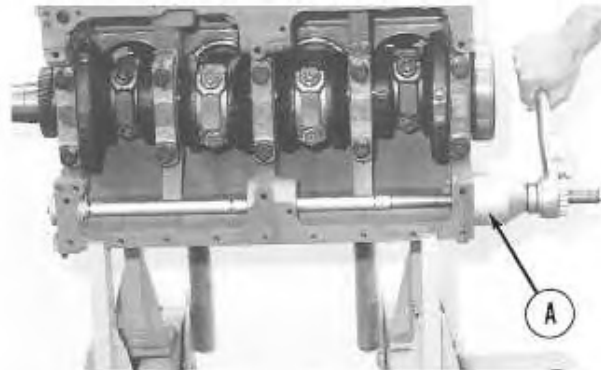

Illustration 2

g00602186

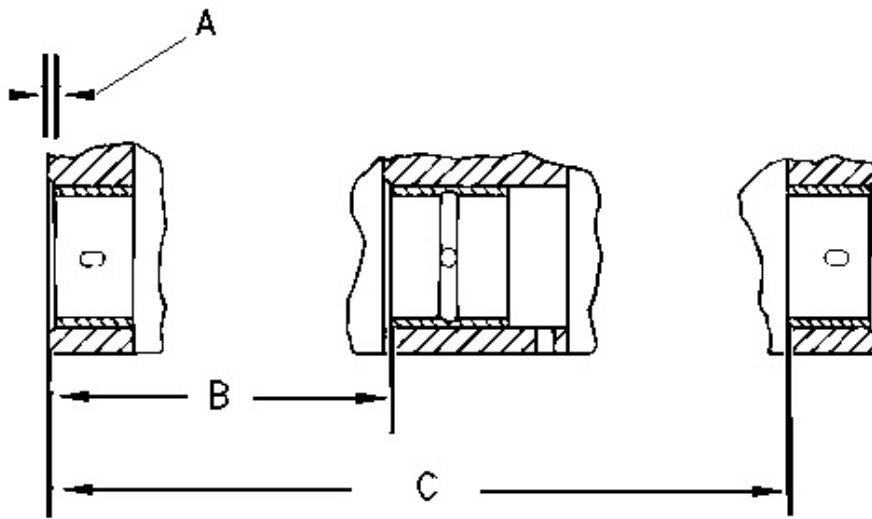

Illustration 3

g00602205

(A) The front bearing depth is 0.8 ± 0.5 mm (0.03 ± 0.02 inch).

(B) The center bearing depth is 290.6 ± 0.5 mm (11.44 ± 0.02 inch).

(C) The rear bearing depth is 601.0 ± 0.5 mm (23.66 ± 0.02 inch).

NOTICE

Keep all parts clean from contaminants.

Contaminants may cause rapid wear and shortened component life.

NOTICE

Care must be taken to ensure that fluids are contained during performance of inspection, maintenance, testing, adjusting and repair of the product. Be prepared to collect the fluid with suitable containers before opening any compartment or disassembling any component containing fluids.

Refer to Special Publication, NENG2500, "Caterpillar Tools and Shop Products Guide" for tools and supplies suitable to collect and contain fluids on Caterpillar products.

Dispose of all fluids according to local regulations and mandates.

1. Install the balancer shaft front bearing with Tool (A). Ensure that the holes in the bearings are aligned with the holes in the cylinder block. The bearing must be 0.8 ± 0.5 mm (0.03 ± 0.02 inch) inside the front face of the cylinder block after installation.

Thank you so much for reading.
Please click the “Buy Now!”
button below to download the
complete manual.



After you pay.

You can download the most
perfect and complete manual in
the world immediately.

Our support email:

ebooklibonline@outlook.com