

Product: TRACK-TYPE TRACTOR

Model: D6N TRACK-TYPE TRACTOR JAH

Configuration: D6N TRACK-TYPE TRACTOR XL JAH00001-UP (MACHINE) POWERED BY C6.6 Engine

Disassembly and Assembly D6N Track-Type Tractor Power Train

Media Number -KENR5137-08

Publication Date -01/07/2018

Date Updated -25/07/2018

i06691352

Final Drive - Disassemble

SMCS - 4050-015

Disassembly Procedure

Table 1

Required Tools			
Tool	Part Number	Part Description	Qty
A	439-3938	Link Bracket	3
B	1P-0074	Slide Hammer Puller Gp	1
C	FT-1934	Puller Beam	1
	-	(16 mm x 190.5 mm) Bolt	4
	5P-8247	Hard Washer	4
	6V-3170	Double Acting Cylinder	1
	9U-6600	Hand Hydraulic Pump	1
	1P-0521	Driver Group	1
D	439-3940	Bracket As	2

Start By:

- a. Remove the final drive.
-

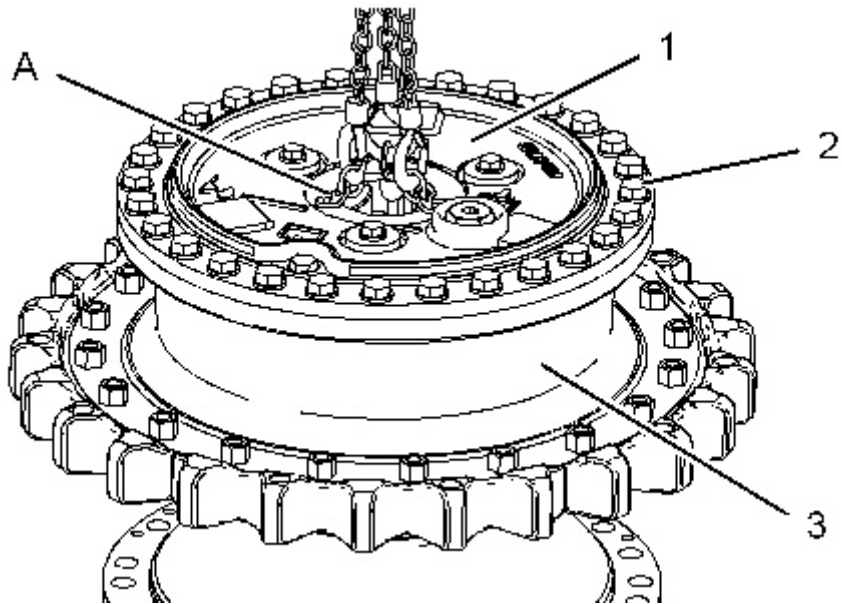

Illustration 1

g01234745

1. Attach Tooling (A) and a suitable lifting device to carrier (1). The weight of carrier (1) is approximately 50 kg (110 lb).
2. Remove bolts (2) and carrier (1) from sprocket hub (3). Position carrier (1) onto suitable cribbing.

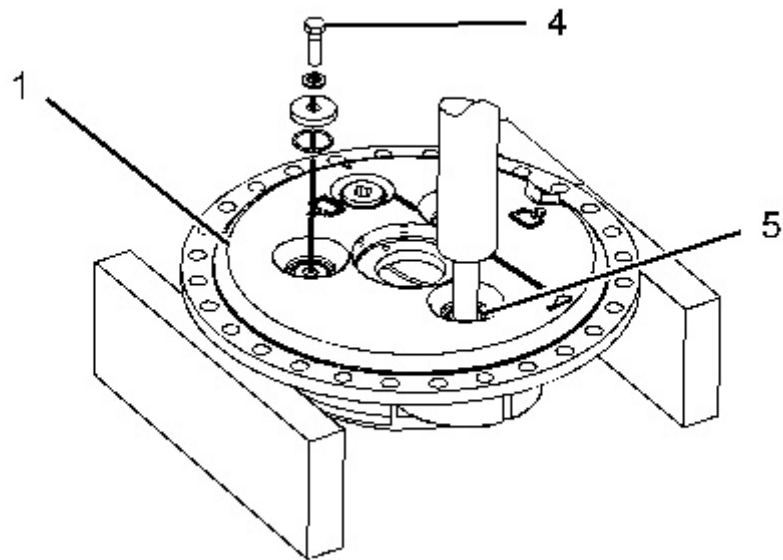

Illustration 2

g01234760

3. Remove bolt (4), the washer, the retainer, and the O-ring seal from carrier (1).
4. Use a suitable press to remove shaft (5) from carrier (1).
5. Repeat Steps 3 and 4 for the remaining shafts.

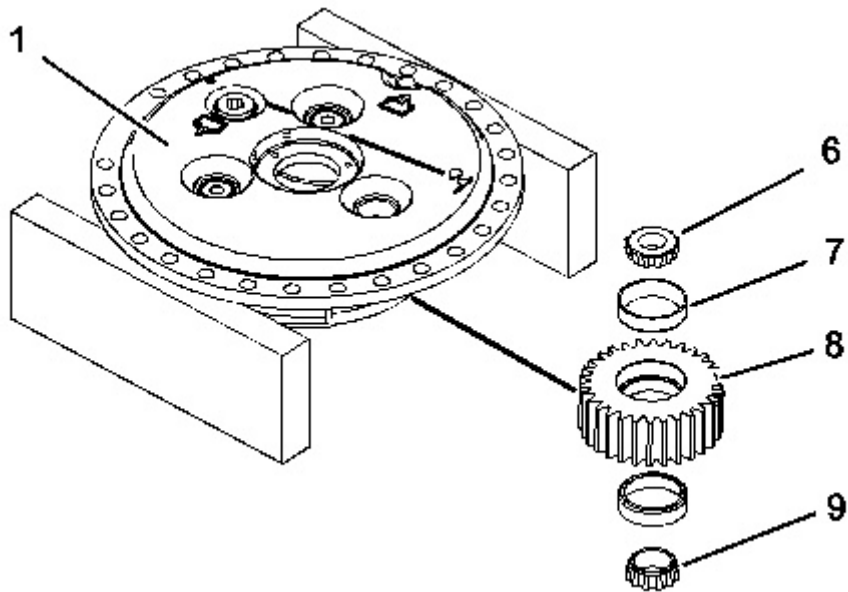
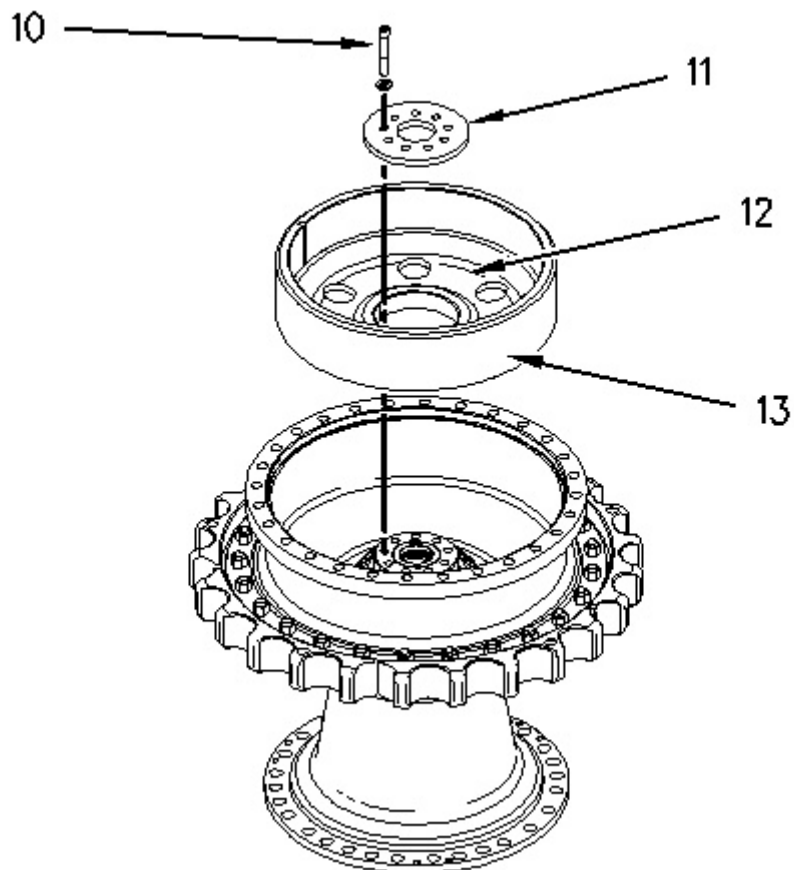

Illustration 3

g06077476

6. Remove planetary gear (8) from carrier (1).
7. Remove bearing cones (6) and (9) from planetary gear (8).
8. Remove bearing cups (7) from planetary gear (8).
9. Repeat Steps 6 through 8 for the remaining planetary gears.



10. Remove bolts (10) and retainer (11).
 11. Remove ring gear hub (12) and ring gear (13).
-

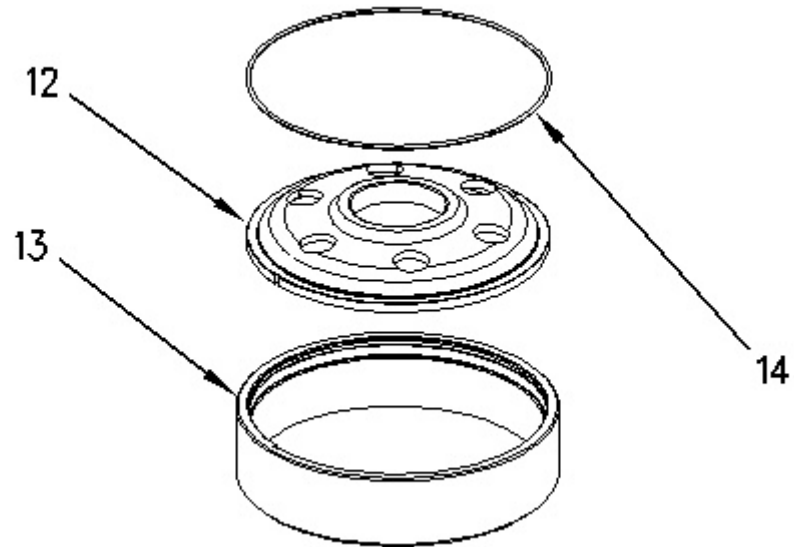

12. Remove ring (14) and ring gear hub (12) from ring gear (13).
-

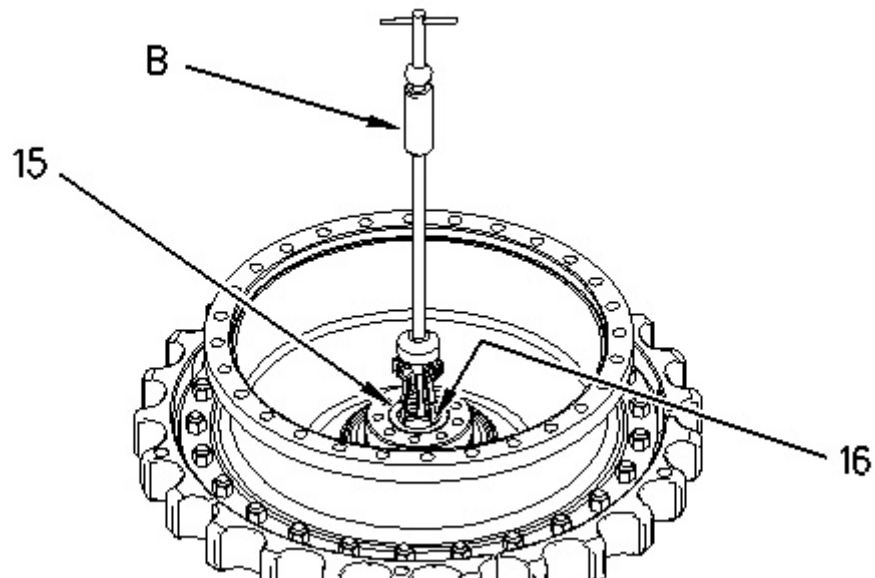

13. Use Tooling (B) to remove bushing (15) and lip-type seal (16) (not shown).
-

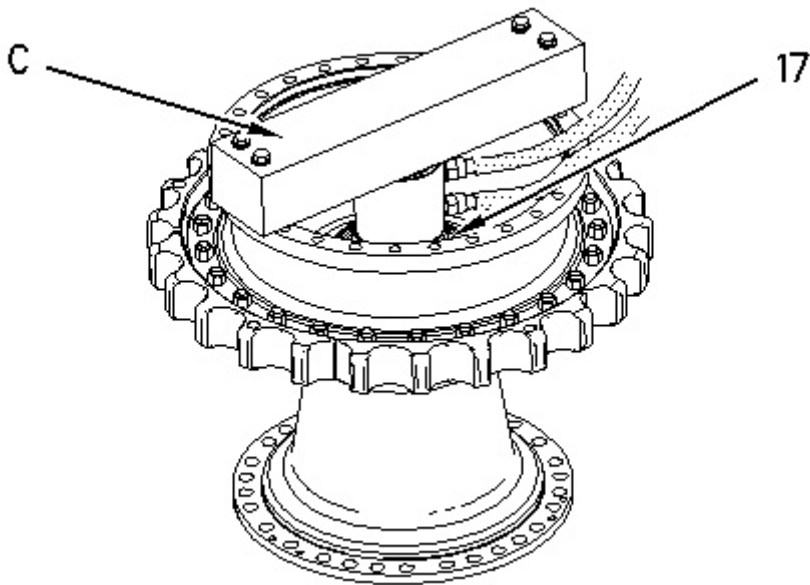

Illustration 7

g00988979

14. Raise the temperature of bearing cone (17).
15. Use Tooling (C) to remove bearing cone (17) from the spindle.

Note: Do not lift the sprocket hub so that the sprocket hub contacts the fittings that are on the hydraulic cylinder. Damage to the fittings could occur.

16. Remove Tooling (C).

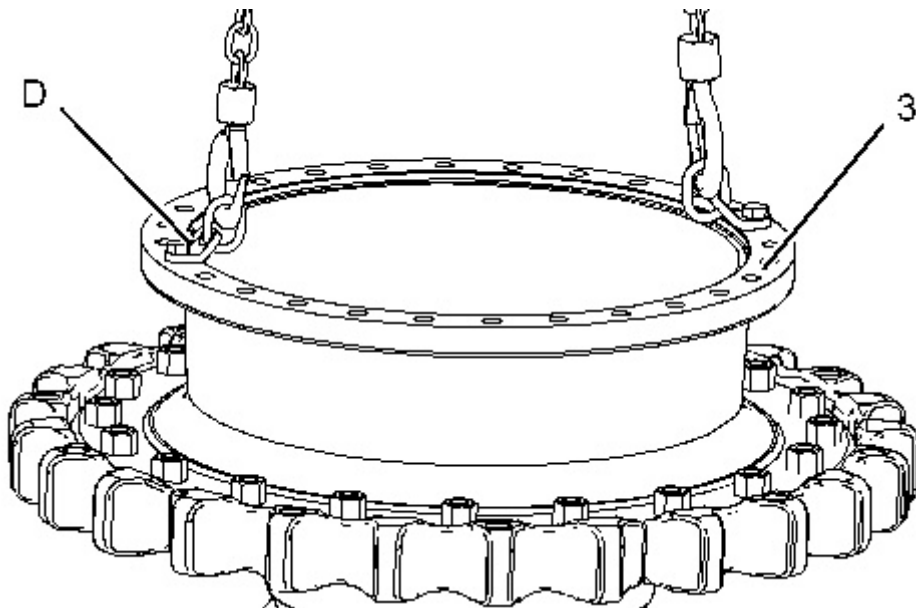

Illustration 8

g01235181

17. Attach Tooling (D) and a suitable lifting device to sprocket hub (3). The weight of sprocket hub (3) is approximately 135 kg (298 lb). Remove sprocket hub (3) from the spindle.

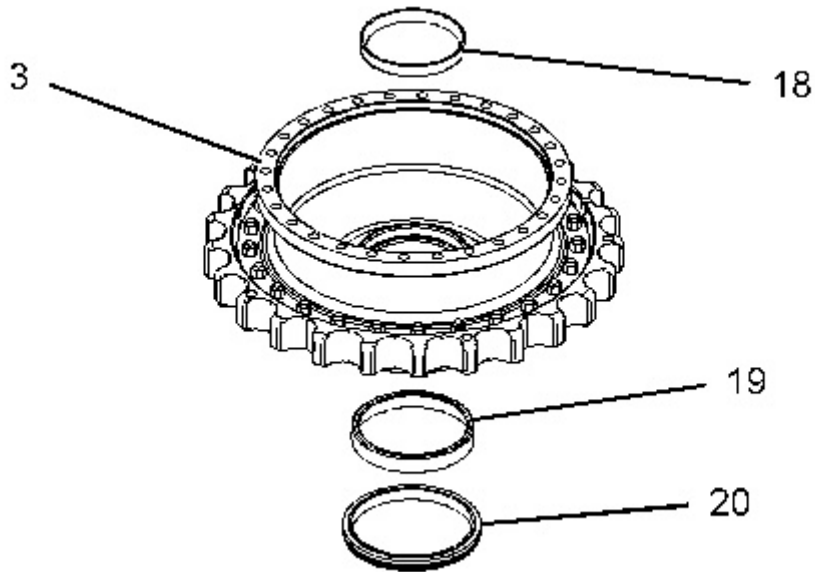

Illustration 9

g01235238

18. Remove bearing cups (18) and (19) from sprocket hub (3).
 19. Remove Duo-cone seal (20) from sprocket hub (3).
-

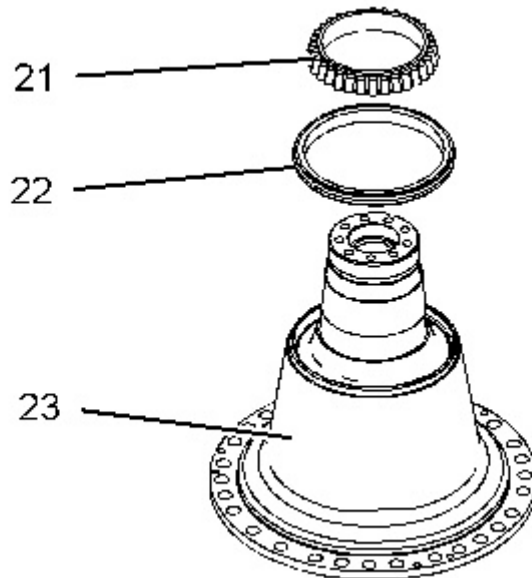

Illustration 10

g01235241

20. Remove Duo-cone seal (22) from spindle (23).
 21. Remove bearing cone (21) from spindle (23).
-

Product: TRACK-TYPE TRACTOR

Model: D6N TRACK-TYPE TRACTOR JAH

Configuration: D6N TRACK-TYPE TRACTOR XL JAH00001-UP (MACHINE) POWERED BY C6.6 Engine

Disassembly and Assembly D6N Track-Type Tractor Power Train

Media Number -KENR5137-08

Publication Date -01/07/2018

Date Updated -25/07/2018

i03902166

Final Drive - Assemble

SMCS - 4050-016

Assembly Procedure

Table 1

Required Tools			
Tool	Part Number	Part Description	Qty
A	138-7573	Link Bracket	3
D	138-7575	Link Bracket	2
E	1P-0520	Driver Gp	1
F	169-0503	Installation Kit	1
	8M-9395	Seal Installer	1
G	1U-7234	Feeler Gauge	1

Thank you so much for reading.
Please click the “Buy Now!”
button below to download the
complete manual.



After you pay.

You can download the most
perfect and complete manual in
the world immediately.

Our support email:

ebooklibonline@outlook.com