



Service Repair Manual

Models

D6R II TRACK-TYPE TRACTOR

Product: TRACK-TYPE TRACTOR

Model: D6R II TRACK-TYPE TRACTOR BRE

Configuration: D6R SERIES II TRACK-TYPE TRACTOR DS XW BRE00501-UP (MACHINE) POWERED BY C-9 ENGINE

Disassembly and Assembly D6R Series II Track-Type Tractor Power Train

Media Number -REN4271-03

Publication Date -01/10/2007

Date Updated -12/10/2007

i07321002

Steering Planetary and Brake - Assemble

SMCS - 4132-016

Assembly Procedure

Table 1

Required Tools			
Tool	Part Number	Description	Qty
A	138-7575	Link Bracket	3
D	6V-6640	Sealant	1

Reference: Refer to Specifications, "Brake and Planetary" in the Service Manual for your machine.



Illustration 1

g00819345

Note: Orient the disc spring with the outer edge downward.

1. Install ring (30) and spring (29) in housing (5).



Illustration 2

g00622157

2. Apply clean oil to seal ring (28).

Note: Orient the seal ring with the lip downward. Refer to Illustration 2.

3. Install seal ring (28) in piston (24).



Illustration 3

g00622156

4. Install piston (24) and O-ring seal (27) in the housing.



Illustration 4

g00622155

- Lower the temperature of bearing cups (25). Install bearing cups (25) in retainer (23).

Note: Orient the seal ring with the lip downward. Refer to Illustration 4.

- Apply clean oil to seal ring (26). Install seal ring (26) in retainer (23).



Illustration 5



Improper assembly of parts that are spring loaded can cause bodily injury.

To prevent possible injury, follow the established assembly procedure and wear protective equipment.

- Install retainer (23) on piston (24). Align the oil passage in retainer (23) with the oil passage and the O-ring seal in the housing. Install bolts (22).



Illustration 6

8. Install sun gear (18) in planetary carrier (10).
9. Install bearings (21) in planetary gear (19).
10. Install discs (20) and planetary gear (19) in planetary carrier (10). Install shaft (16).



Illustration 7

g00622128

Note: If the rubber in pin (17) is damaged, replace pin (17).

11. Align the hole in shaft (16) with the hole in planetary carrier (10) and install pin (17). Install pin (17) until the pin is even with the surface of planetary carrier (10).
12. Repeat Steps 9 through 11 for the remaining planetary gears.

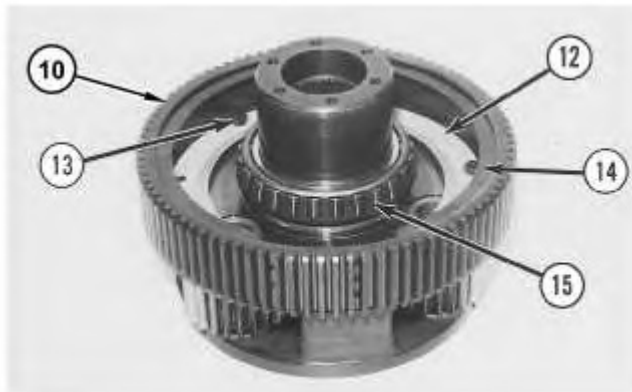

Illustration 8

g01205303

Note: If bearing cone (15) was removed from planetary carrier (10), a new bearing must be installed.

13. Raise the temperature of bearing cone (15). Install the bearing cone on planetary carrier (10).
14. Apply Tooling (D) to the flange of slinger (12).
15. Install slinger (12) on planetary carrier (10). Install bolts (13) and tighten to a torque of $25 \pm 6 \text{ N}\cdot\text{m}$ ($221 \pm 53 \text{ lb in}$).

Thank you so much for reading.
Please click the “Buy Now!”
button below to download the
complete manual.



After you pay.

You can download the most
perfect and complete manual in
the world immediately.

Our support email:

ebooklibonline@outlook.com