

Product: TRACK-TYPE TRACTOR

Model: D6T LGP TRACK-TYPE TRACTOR JRW

Configuration: D6T TRACK-TYPE TRACTOR XL, XW, LGP JRW00001-UP (MACHINE) POWERED BY C9 Engine

Disassembly and Assembly D6T Track-Type Tractor Power Train

Media Number -KENR8911-03

Publication Date -01/03/2016

Date Updated -07/03/2016

i06151275

Bevel and Transfer Gears - Disassemble

SMCS - 3011-015

Disassembly Procedure

Table 1

Required Tools			
Tool	Part Number	Part Description	Qty
A	138-7575	Link Bracket	3
B	138-7575	Link Bracket	1
C	8H-0663	Bearing Puller	1
D	8T-2839	Spanner	1
E	1P-1863	Retaining Ring Pliers	1
F	1P-2321	Puller Assembly	1
	5P-4170	Step Plate	1
G	5J-0490	Forcing Screw 1/2 inch X 13 X 5 inch	2
H		Forcing Bolt 1/4 inch X 20	1

Start By:

- A. Separate the transmission and bevel gears.

Note: Put identifying marks on all of the shims as the shims are removed. The identifying marks will ensure correct installation at assembly.



Illustration 1

g00504390

1. Remove bolts (1) and roller brackets (2) from each side of the transfer gear case.



Illustration 2

g01206244

2. Remove and discard bolts (4) that hold transfer gear case (3) to the bevel gear case.
 3. Install Tooling (A) and attach a suitable lifting device to Tooling (A) . Remove transfer gear case (3) from the bevel gear case. The weight of transfer gear case (3) is approximately 101 kg (223 lb).
-



Illustration 3

g00839158

4. Remove bolts (5) that hold cage (6) to transfer gear case (3) .
5. Install Tooling (G) . Tighten Tooling (G) evenly. Remove the cage and the shims from the transfer gear case.

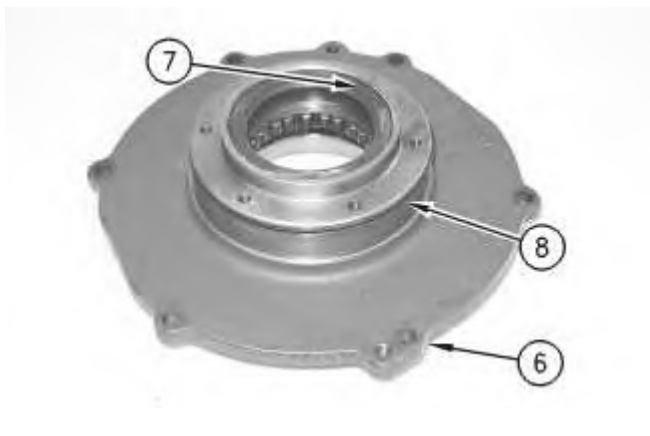

Illustration 4

g00830580

6. Remove lip seal (7) and O-ring seal (8) from cage (6) .



NOTICE

Bearing cup (9) and bearing (10) will be damaged if the bearing cups are removed.

7. Remove bearing cup (9) and bearing (10) from cage (6) , if necessary.

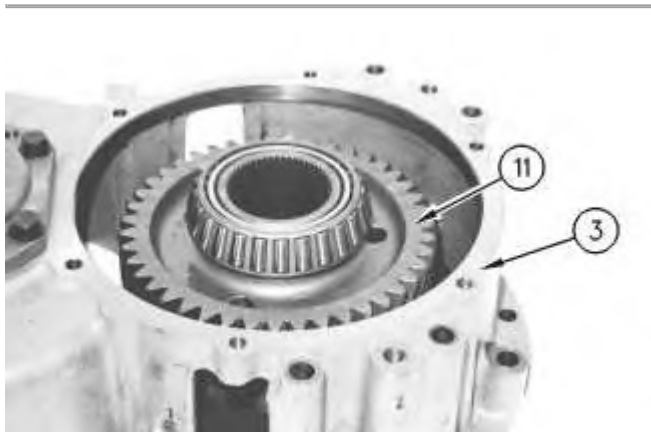

Illustration 6

g00504398

8. Remove transfer gear (11) from transfer gear case (3) .

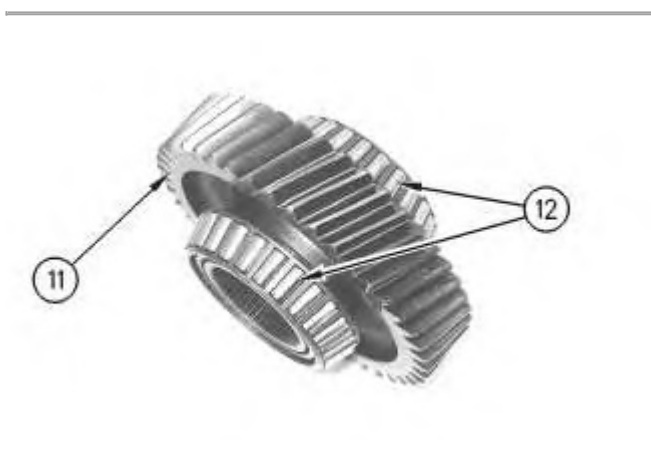

Illustration 7

g00504399

NOTICE

Bearing cones (12) will be damaged if the bearing cones are removed from transfer gear (11) .

9. Remove bearing cones (12) from transfer gear (11) , if necessary.

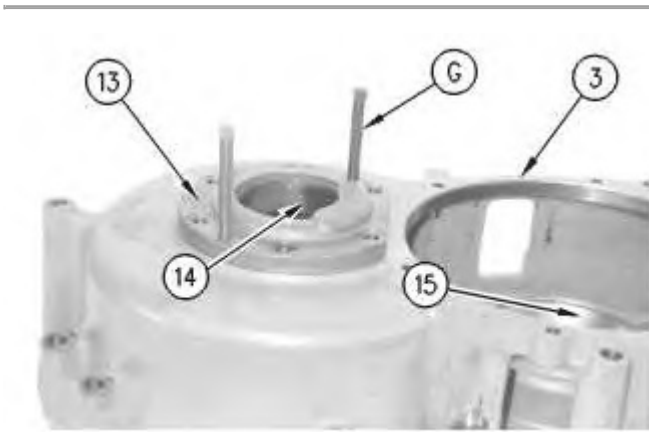

Illustration 8

g00839162

10. Remove the bolts and install Tooling (G) in cage (13) . Tighten Tooling (G) evenly and remove cage (13) and the shims from transfer gear case (3) .
11. Remove bearing cup (14) from cage (13) .
12. Remove bearing cup (15) from transfer gear case (3) .

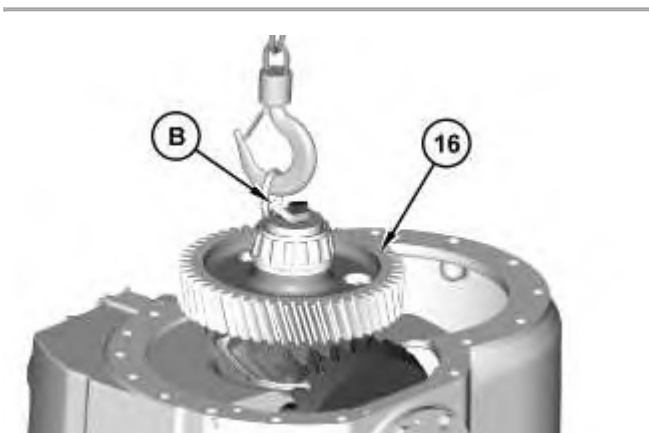

Illustration 9

g01206569

13. Remove the bolt and the retainer from pinion gear assembly (16) .
14. Install Tooling (B) and attach a suitable lifting device. Remove pinion gear assembly (16) from the bevel gear case. The weight of pinion gear assembly (16) is approximately 33 kg (73 lb).

15. Remove the bearing cup for the pinion gear assembly from the bevel gear case.

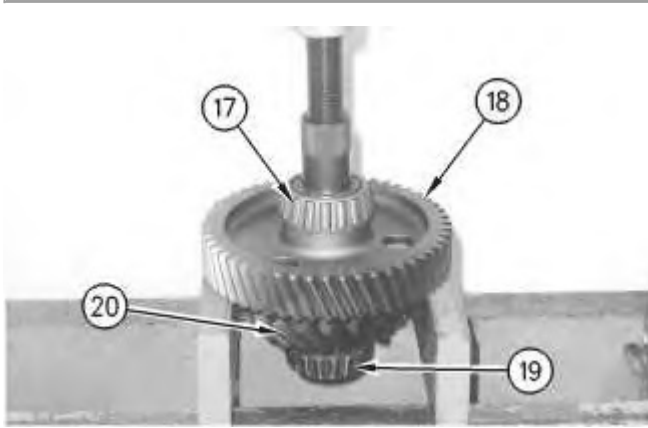

Illustration 10

g00504402

16. Put the pinion gear assembly in a suitable press. Remove transfer gear (18) and bearing cone (17) from bevel pinion gear (20) .
17. Use Tooling (C) and a suitable press to remove bearing cone (19) from bevel pinion gear (20) .



Illustration 11

g00504403

18. Bend the locking tab away from spanner nut (22) .
 19. Place a pry bar between the bolt heads on the bevel gear. The prybar will prevent rotation of the bevel gear shaft.
 20. Use Tooling (D) and remove spanner nut (22) . Remove lockwasher (21) and the tongue washer.
-

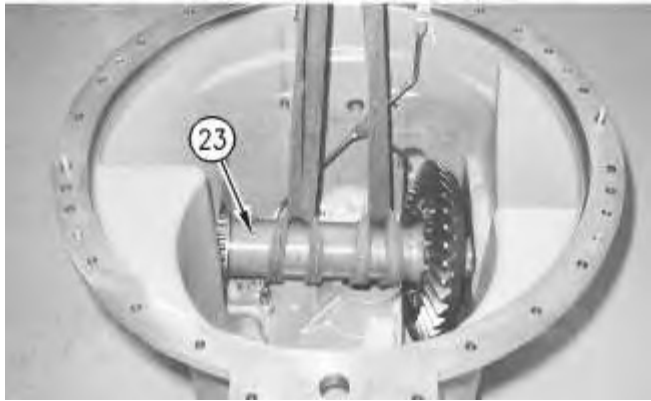

Illustration 12

g00504404

21. Use the lifting sling and a suitable lifting device to support the bevel gear and shaft (23) in order to remove the bearings. The weight of the bevel gear and shaft (23) is approximately 55 kg (121 lb).

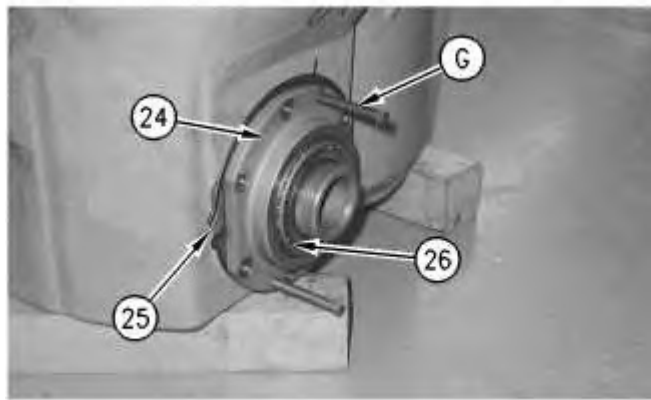

Illustration 13

g00839205

Thank you so much for reading.
Please click the “Buy Now!”
button below to download the
complete manual.



After you pay.

You can download the most
perfect and complete manual in
the world immediately.

Our support email:

ebooklibonline@outlook.com