

Tools Needed		A	B	C	D	E	F
5P9736	Link Bracket	1					
1P3075	Puller Assembly		1				
8B7548	Puller Assembly			1			1
8H684	Ratchet Box Wrench			1			1
8B7554	Bearing Cup Puller Attachment			1			
FT1442	Lift Bracket				1		
	Plate 6 7/8" (174.6 mm) Outside Diameter x 1 1/2" (38.1 mm) Thick					1	
5P3100	Pump Group (or electric)					1	
5F7343	Bearing Puller Attachment					1	
8B7560	Step Plate					1	
1P820	Puller Group					1	
1H3107	Puller Assembly					1	
1H3108	Leg					2	
8B7550	Leg						2
8B7551	Bearing Puller Attachment						1

START BY:

a) remove sprocket assemblies

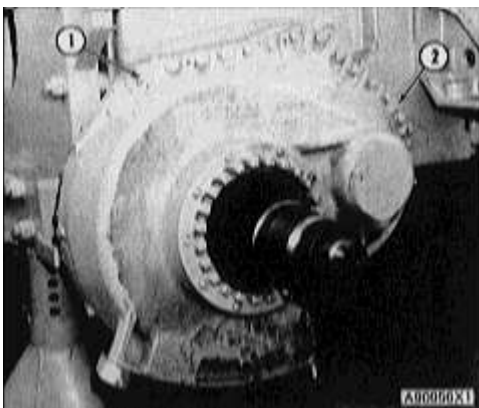

1. Remove bolts (1) that hold final drive case (2) in position.

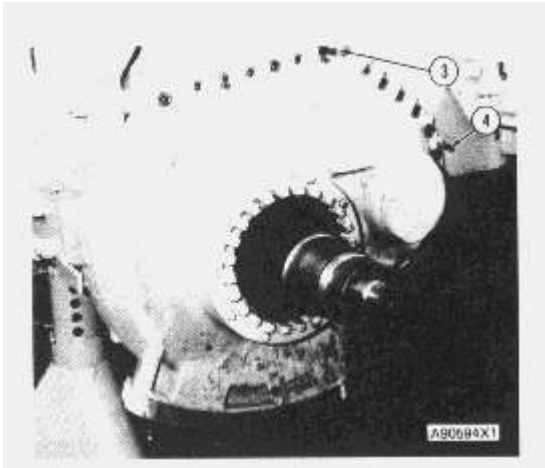

2. Install two 5/8"-11 NC guide bolts (3). Install three 1/2"-13 NC forcing screws (4).
3. Tighten the forcing screws evenly until the case is approximately .25 in. (6.4 mm) away from the steering clutch case.
4. Install a piece of wire around the guide pins to hold the idler pinion in place.

NOTICE

The wire is to keep the planet carrier in position so it will not fall from the steering clutch case when the final drive case is removed.

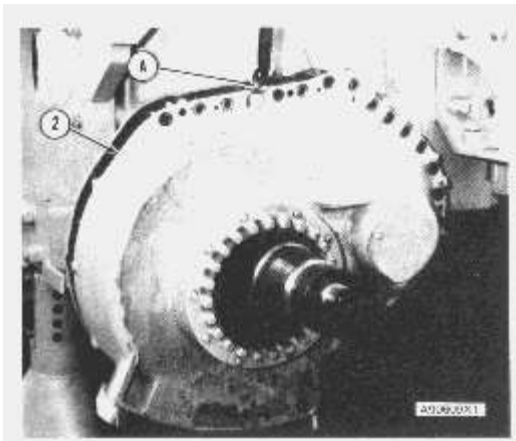

5. Tighten the forcing screws until tool (A) and a hoist can be fastened to final drive case (2). Remove final drive case (2). The weight is 280 lb. (127 kg.)

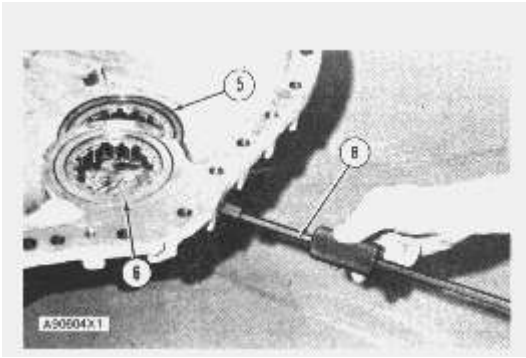

6. Remove the plugs for the dowels that hold race and roller assemblies (5) and (6) in place with tooling (B).

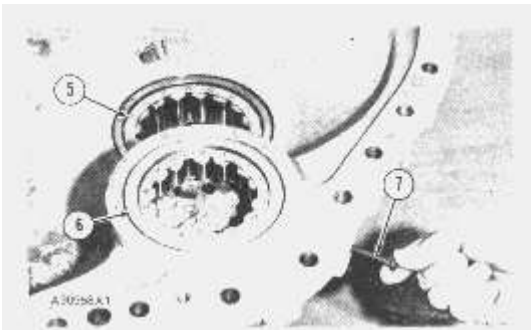

7. Remove the dowel for race and roller assembly (6) with a 10-32 screw (7). Remove the dowel for race and roller assembly (5) with a 1/4"-20 NC bolt.

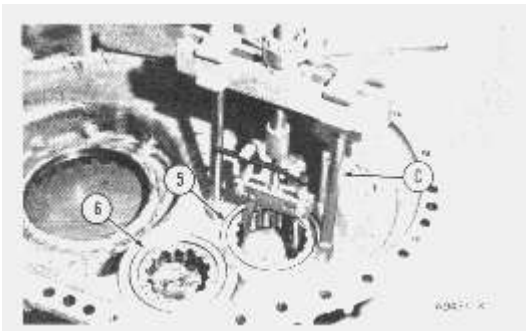

8. Use tooling (C) and remove race and roller assemblies (5) and (6) from the final drive case.

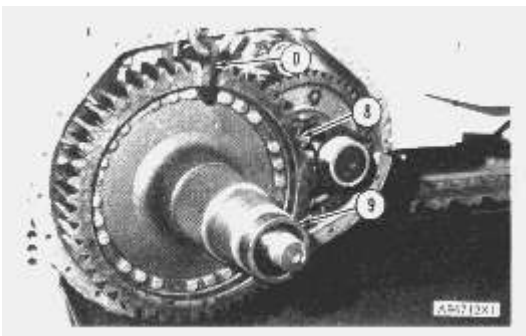

9. Install tool (D) on gear (8). Fasten a hoist. Remove gear (8) and hub (9) from the sprocket shaft. Put the gear and hub on wood blocks. The weight of the gear and hub is approximately 350 lb. (159 kg)

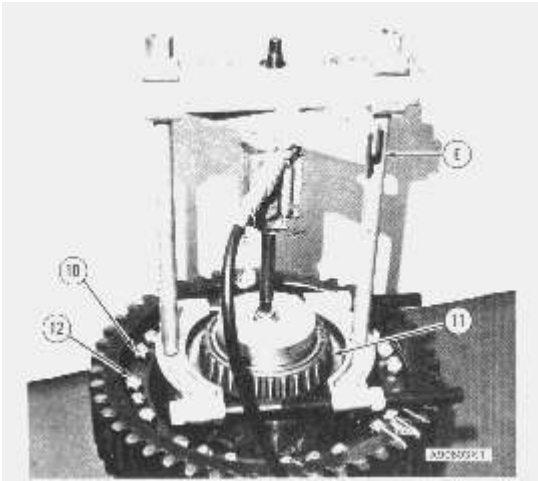

Typical Example

10. Remove bearing cone (11) from the hub with tooling (E).

11. Remove nuts (10) and locks from bolts (12). Remove bolts (12) with a soft punch and hammer.

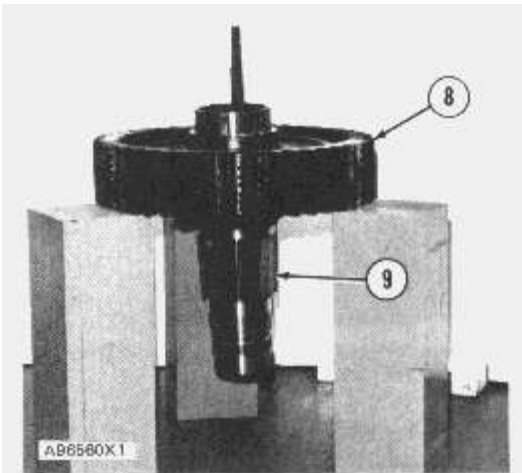

Typical Example

12. Use a nylon strap and a pin or bolt with a length that is longer than the inside diameter of the hub to fasten a hoist to the hub. Remove hub (9) from gear (8). The weight is 218 lb. (99 kg)

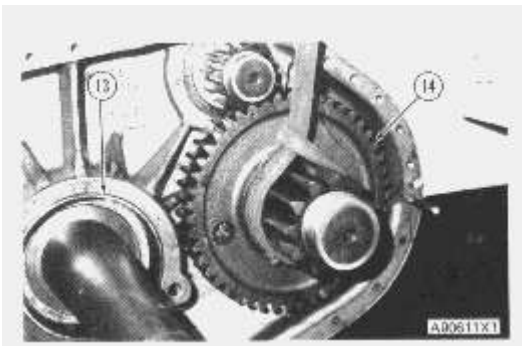

13. Remove bearing cup (13) if necessary.

14. Remove the wire from the gear and pinion. Fasten a hoist and remove gear (14) and the pinion from the steering clutch case. The weight is 120 lb. (54 kg).

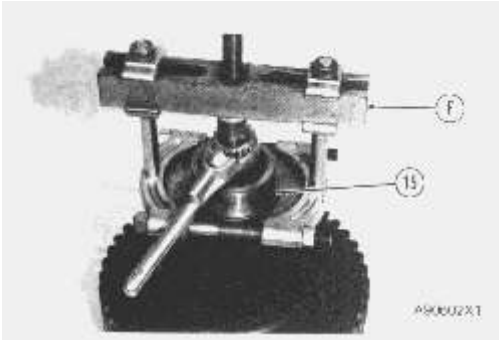

15. Remove bearing race (15) with tooling (F) from the pinion shaft.

NOTE: Step 16 is for later models only with a two piece pinion and gear assembly. Earlier models, the pinion and gear are one piece.

NOTICE

Too much pressure on the pinion shaft can cause damage to the gear.

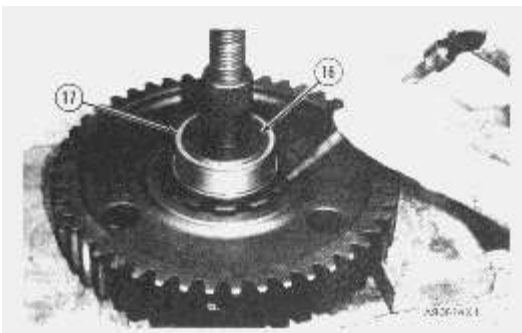

Typical Example

16. Remove pinion shaft (16) from the gear as follows:

a) Put the gear and pinion shaft in a press as shown.

b) Put a small amount of pressure on the pinion shaft with the press. Push the ring in the groove on the pinion shaft with a hammer and punch. The ring will stay in the groove because of the pressure on the pinion shaft.

c) When the ring is completely in the groove, the pinion shaft will slide out of the gear. The weight of the pinion is 85 lb. (39 kg).

17. Remove bearing race (17) from the pinion shaft with tooling (F).

18. Drain the oil from the steering clutch and bevel gear case.

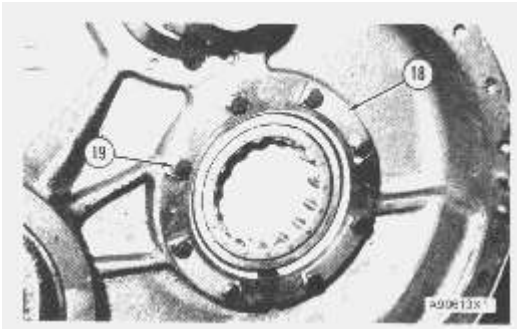

19. Bend locks (18) down. Remove bolts (19) and locks (18).

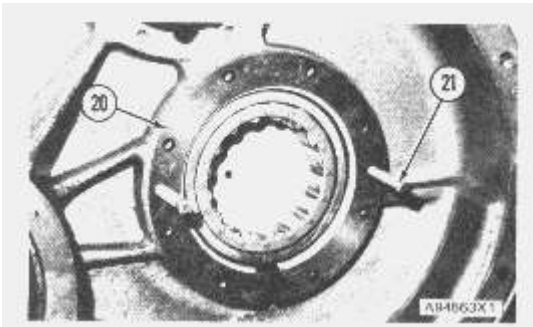

20. Install two 1/2"-13 NC forcing screws (21) in bearing cage (20). Tighten the forcing screws evenly and remove bearing cage (20) from the steering clutch case.

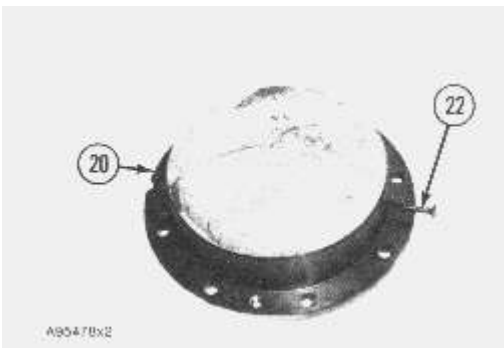

21. Use a 1/4"-20 NC bolt (22) to remove the dowel from cage (20).

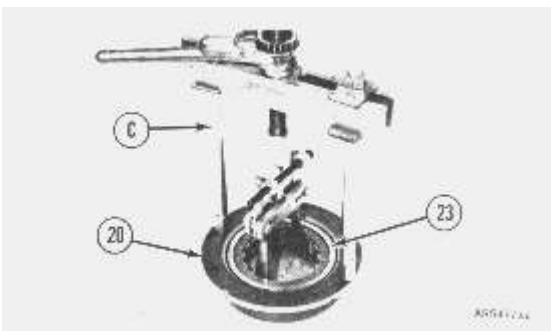

22. Remove race and roller assembly (23) from bearing case (20) with tooling (C).

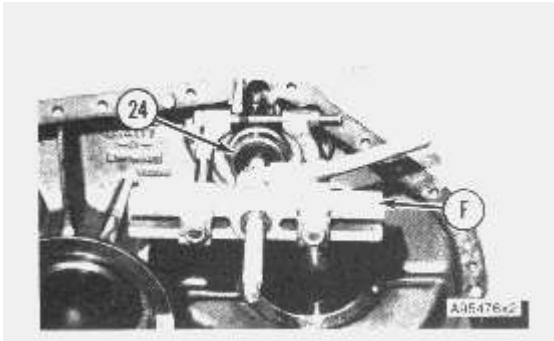

23. If necessary, remove bearing race (24) with tooling (F) from the pinion.

Install Final Drive Cases, Gears, Idler Pinions And Bearings

Tools Needed		A	B
FT1442	Lift Bracket	1	
5P9736	Link Bracket		1

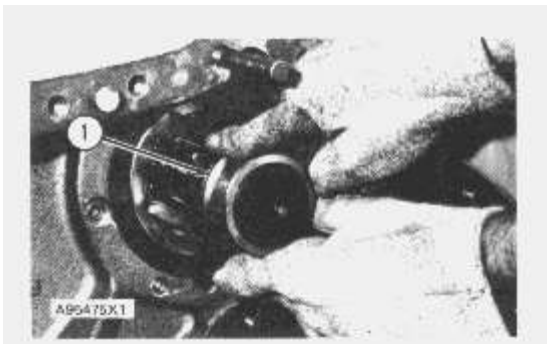

1. Heat bearing race (1) to a maximum temperature of 275°F (135°C). Install bearing race (1) on the pinion shaft.

NOTICE

All race and roller assemblies with snap rings must be assembled with the snap ring next to the gear teeth.

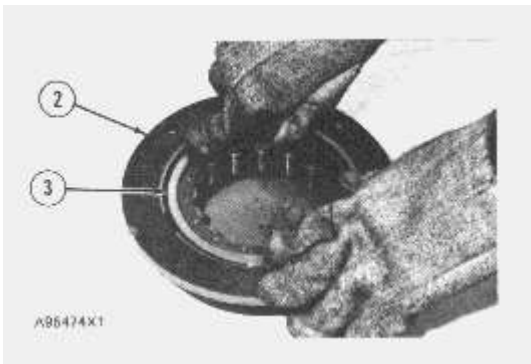

2. Lower the temperature of roller and race assembly (3). Make sure the hole in the race and roller assembly is in alignment with the hole in cage (2) and install race and roller assembly (3).

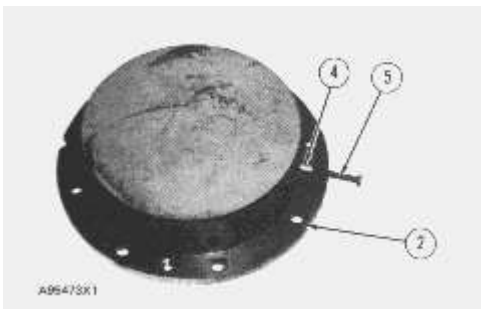

3. Install dowel (4) to hold the race and roller assembly in the cage. Use a 1/4\"-20 NC bolt (5) to install the dowel.

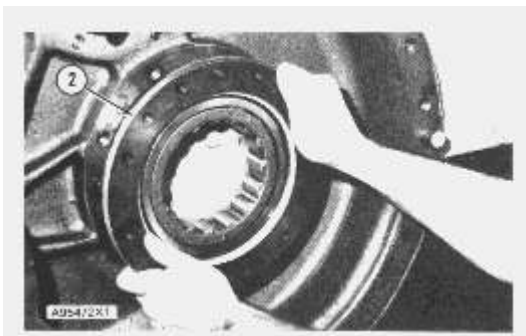

4. Put 7M7260 Liquid Gasket Material on the contact surfaces of the cage and steering clutch case. Put cage (2) in position in the steering clutch case. Make sure the oil groove next to the race and roller assembly is at the bottom.

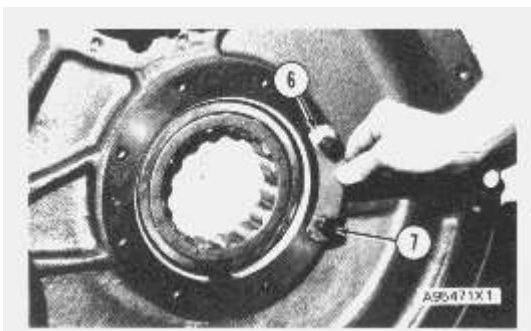

5. Install four locks (6) and eight bolts (7) that hold the cage in place. Bend the locks up.

6. If a separation of the idler gear and pinion was made, install a new retainer in the pinion. Install the gear over the pinion so the deep chamfer is used to put the retainer under compression. Make sure the retainer is engaged in the groove of the gear.

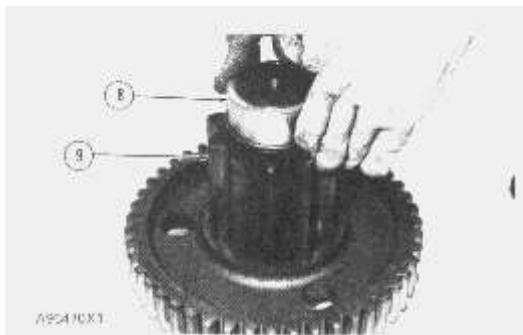

7. Heat bearing races (8) to a maximum temperature of 275°F (135°C) and install them on each end of pinion (9).

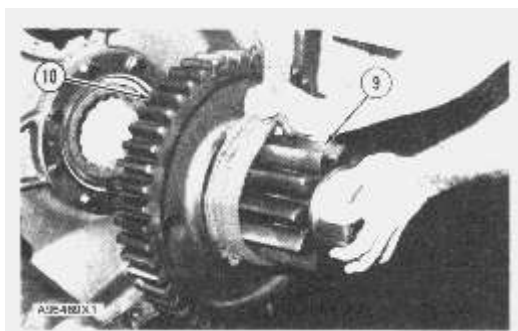

8. Put 5P960 Multiurpose Type Grease in the roller assemblies to hold the rollers out for installation of gear (10) and pinion (9). Fasten a hoist and install gear (10) and pinion (9) in the steering clutch case.

9. Fasten a wire around the guide bolts, gear (10) and pinion (9).

NOTE: The wire will hold the gear and pinion in position until the final drive case is installed.

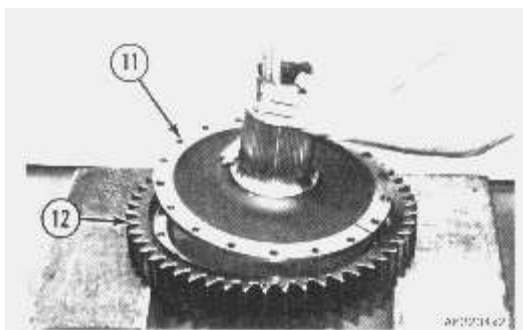

10. Fasten a hoist to hub (11) and put it in position in gear (12). Install the bolts (from the top side), locks and nuts that hold the hub and gear together.

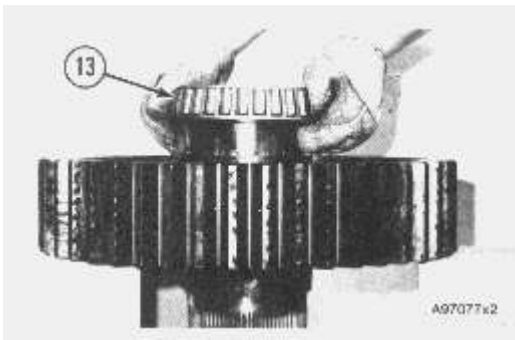

11. Heat bearing cone (13) to a maximum temperature of 275°F (135°C). Install bearing cone (13) on the hub.

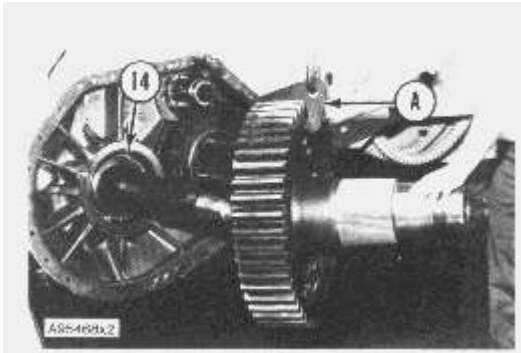

12. Lower the temperature of bearing cup (14). Install bearing cup (14) in the steering clutch case. Make sure the bearing cup is tight against the surface of the counterbore.

13. Use tooling (A) and a hoist and put the hub and gear in position on the sprocket shaft.

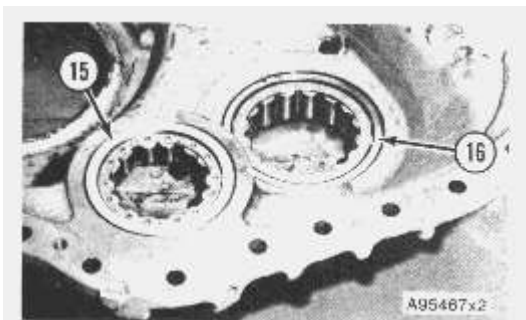

14. Lower the temperature of race and roller assemblies (15) and (16). Make sure the hole in the race and roller assemblies are in alignment with the dowel holes in the case. Install the race and roller assemblies (15) and (16) in the final drive case.

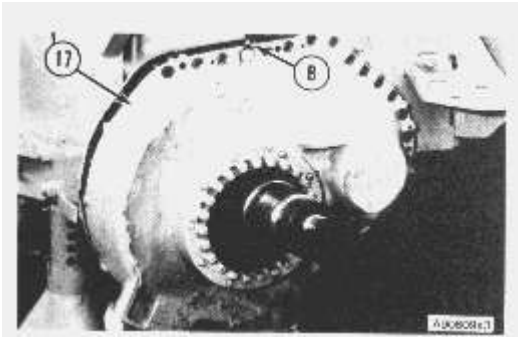

Typical Example

15. Install the dowels and plugs in final drive case (17) to hold the race and roller assemblies in place. Put 5P960 Multipurpose Type Grease on the roller assemblies to hold the rollers out to prevent damage to parts when final drive case (17) is installed.

16. Install tooling (B) and a hoist to the final drive case. Put 7M7260 Liquid Gasket Material on the contact surfaces of the steering clutch case and final drive case.

17. Put the final drive case on the guide bolts and remove tooling (B) and the wire used to hold the pinion.

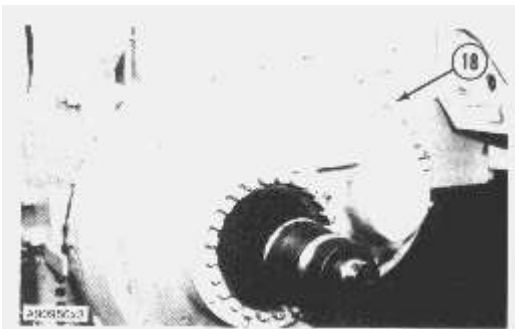

18. Push final drive case (17) against the steering clutch case. Install bolts (18) and washers that hold final drive case (17). Tighten the bolts to a torque of 200 ± 20 lb.ft (270 ± 25 N·m).

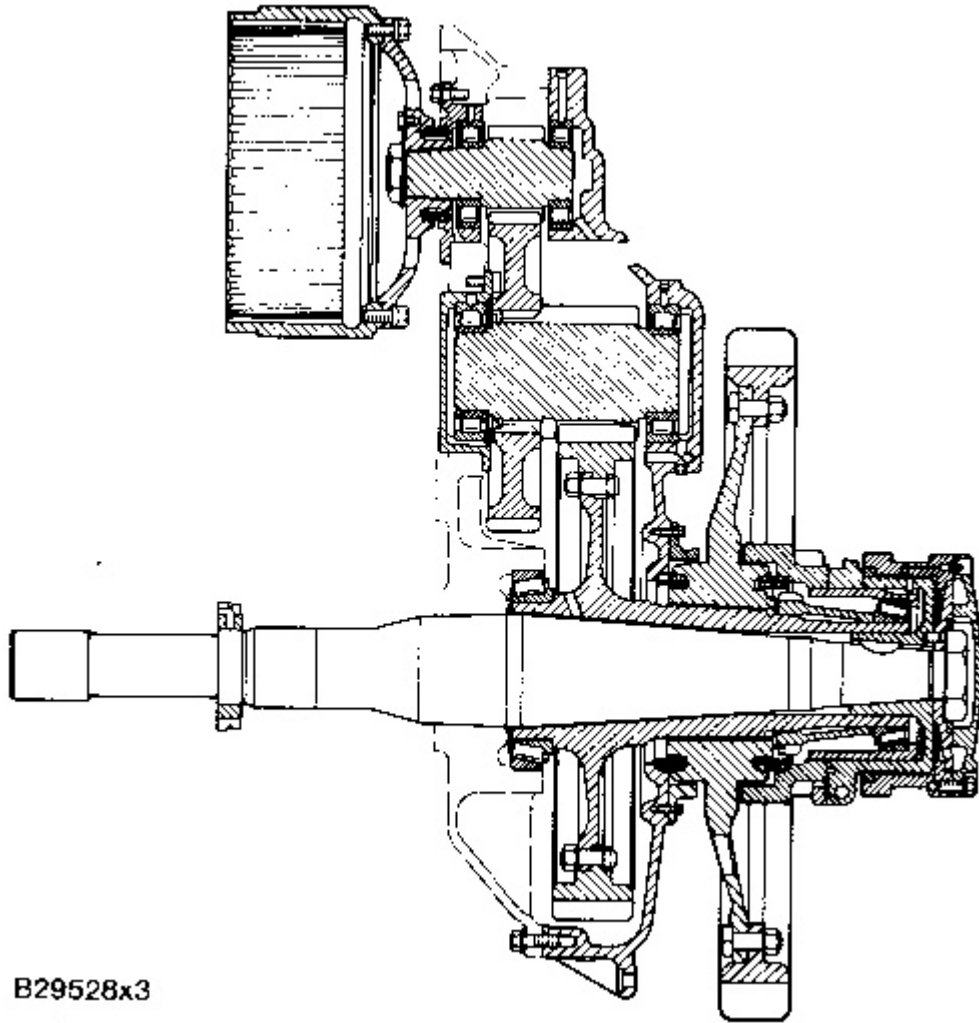

B29528x3

19. Fill the steering clutch case and final drive cases with oil to the correct level. See Maintenance Guide.

END BY:

a) install sprocket assemblies

Product: TRACK-TYPE TRACTOR

Model: D7G TRACK-TYPE TRACTOR 64V

Configuration: D7G TRACK-TYPE TRACTOR / DIRECT DRIVE / 64V00995-UP (MACHINE) POWERED BY 3306 ENGINE

Disassembly and Assembly D7G TRACTOR POWER TRAIN

Media Number -SEN7119-02

Publication Date -01/02/1983

Date Updated -14/10/2004

SEN71190014

Adjustment For The Final Drive Bearings

SMCS - 4059-11; 4059; 4075-12

Adjustment For The Final Drive Bearings

Tools Needed		A	B	C	D	E
8S7630	Stand	2				
8S7611	Tube	2	2			
8S7615	Pin	2	2			
8S7640	Stand			2		
6V82	Tool Arrangement			1		
4B5273	Washer			3		
1A5822	Bolt			3		
5P3508	Torque Multiplier				1	
9S7351	Torque Wrench				1	1
2P8261	Adapter					1

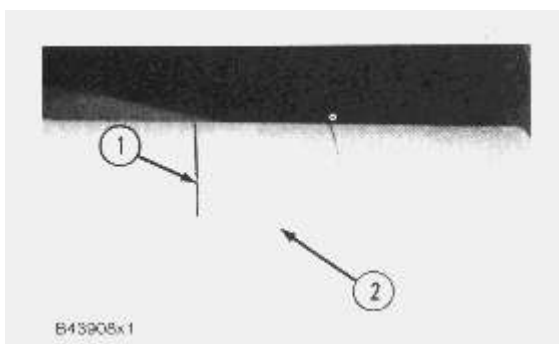

Thank you so much for reading.
Please click the “Buy Now!”
button below to download the
complete manual.



After you pay.

You can download the most
perfect and complete manual in
the world immediately.

Our support email:

ebooklibonline@outlook.com