



Service Repair Manual

Models

D7R II TRACK-TYPE TRACTOR

Product: TRACK-TYPE TRACTOR

Model: D7R II TRACK-TYPE TRACTOR ACS

Configuration: D7R Track-Type Tractor ACS00001-UP (MACHINE) POWERED BY 3176C Engine

Disassembly and Assembly D7R and D7R Series II Track-Type Tractors Power Train

Media Number -REN3657-02

Publication Date -01/02/2009

Date Updated -18/02/2009

i02529031

Final Drive - Disassemble

SMCS - 4050-015

Disassembly Procedure

Table 1

Required Tools			
Tool	Part Number	Part Description	Qty
A	138-7575	Link Bracket	3
B	1P-0510	Driver Group	1
C	8B-7548	Puller Assembly	1
	8H-0684	Ratchet Box Wrench	1
	8B-7554	Bearing Cup Puller Attachment	1
D	138-7573	Link Bracket	2
E	1P-0520	Driver Group	1
F	138-7573	Link Bracket	3
G	1P-0520	Driver Group	1
	6V-3160	Cylinder	1
	1D-4620	Bolt 3/4 inch -10 × 7 inch long	4
	FT-1934	Beam	1
	5P-8248	Washers	4
	4C-4865	Pump	1

Start By:

- a. Remove the final drives. Refer to Disassembly and Assembly, "Final Drive - Remove".

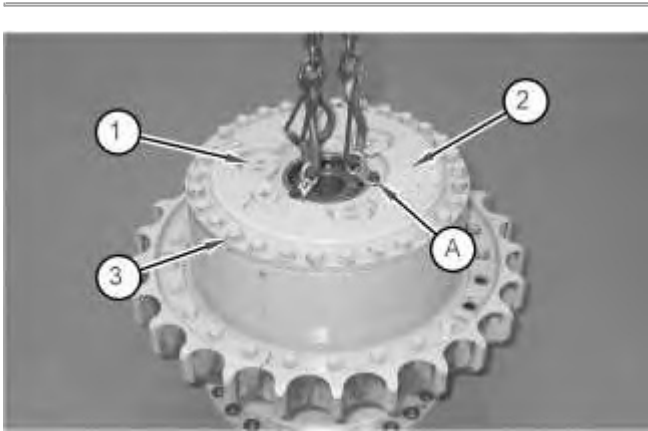

Illustration 1

g01265376

1. Attach Tooling (A) and a suitable lifting device to planetary carrier (2). The weight of planetary carrier (2) is approximately 105 kg (231 lb).
2. Remove bolts (3) and planetary carrier (2).
3. Remove bolts (1) and the O-ring seal from each of the plates.

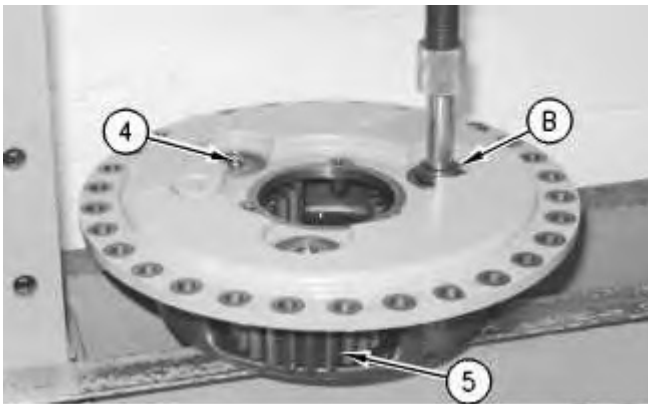

Illustration 2

g00504707

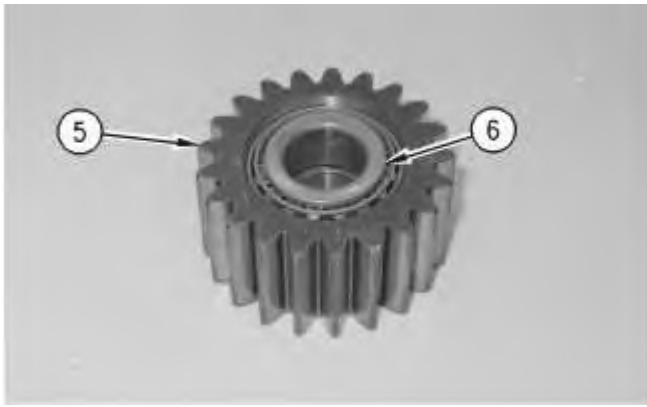

Illustration 3

g00504708

4. Use Tooling (B) and a suitable press in order to remove shafts (4).
5. Remove gears (5).
6. Remove bearing cones (6) from each side of gears (5).

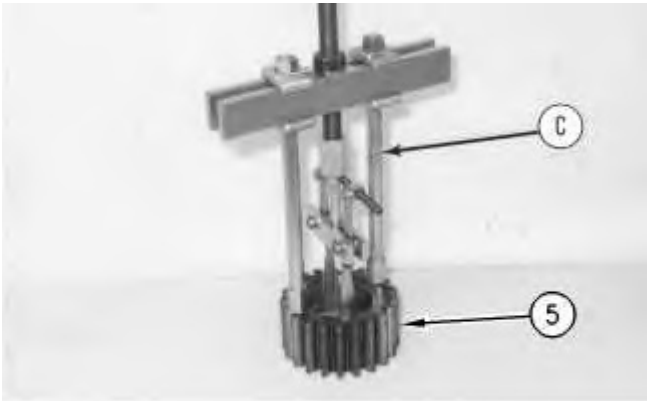

Illustration 4

g00830055

7. Use Tooling (C) in order to remove the bearing cups from each side of gears (5).

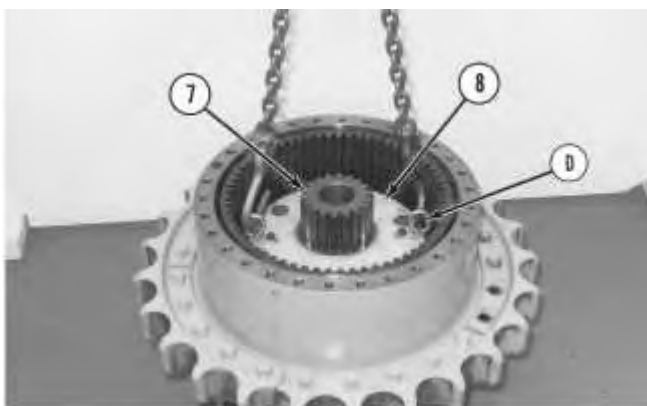

Illustration 5

g00504710

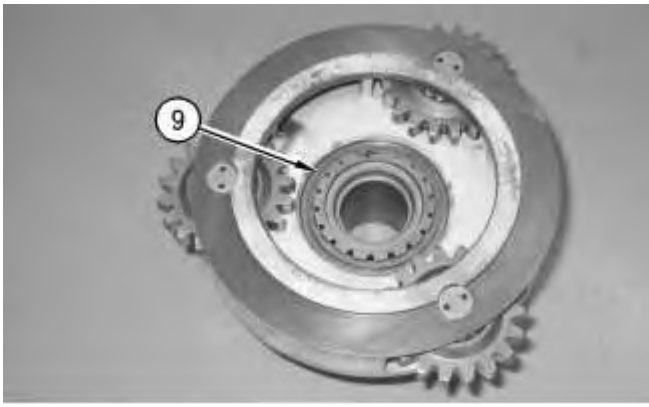

Illustration 6

g00504711

NOTICE

There is a second sun gear that is shown in Step 15 in the center of the planetary carrier. The sun gear is free to fall if the gear stays with the planetary carrier.

8. Install Tooling (D) and a suitable lifting device to planetary carrier (8). The weight of planetary carrier (8) and sun gear (7) is approximately 46 kg (101 lb). Remove planetary carrier (8) and sun gear (7) as a unit.
9. Invert planetary carrier (8) and remove spiral ring (9) from sun gear (7).
10. Use a suitable lifting device in order to remove planetary carrier (8) from sun gear (7). The weight of planetary carrier (8) is approximately 32 kg (70 lb).

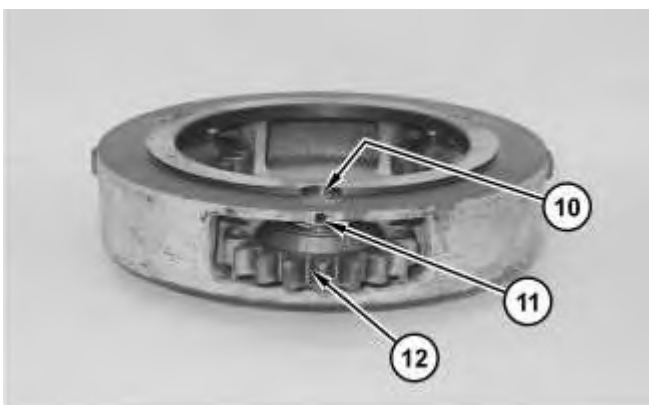

Illustration 7

g01265395

Thank you so much for reading.
Please click the “Buy Now!”
button below to download the
complete manual.



After you pay.

You can download the most
perfect and complete manual in
the world immediately.

Our support email:

ebooklibonline@outlook.com