



Service Repair Manual

Models

D7R TRACK-TYPE TRACTOR

Product: TRACK-TYPE TRACTOR

Model: D7R TRACK-TYPE TRACTOR R7B

Configuration: D7R TRACK-TYPE TRACTOR STD, XR, LGP R7B00001-UP (MACHINE) POWERED BY C9 Engine

Disassembly and Assembly D7R Track-Type Tractor Power Train

Media Number -UENR0042-02

Publication Date -01/02/2015

Date Updated -02/02/2015

i02530951

Final Drive Planetary Carrier (In Chassis) - Install

SMCS - 4092-012

Installation Procedure

Table 1

Required Tools			
Tool	Part Number	Part Description	Qty
A	FT-1952	Installer	1
	8T-3045	Adapter	1
B	1P-0068	Cone	1
	1P-0069	Head	1
	1P-0071	Jaw	3
	FT-0732	Lifting Channel	1
	1A-8285	Nut	3
	6H-0187	Bolt	3
	1P-5546	Block	1
	5P-8247	Washer	1
	1B-4206	Nut	1
C	3B-2968	Bolt 3/4 inch - 10 by 3 1/2 long	1
D	5P-8622	Shackle	1
	8T-3207	Lifting Bracket	1
	1A-8063	Bolts 3/4 inch - 10 by 2 1/2 inch long	2

	5 P-8248	Washers	6
	1B-4331	Nut	2
E	6V-3160	Cylinder	1
	9U-6600	Pump	1
F	1P-1837	Step plate	1
G	1P-0520	Driver Group	1

1. Be sure that all the parts are clean. Inspect the parts for wear or damage. If necessary, replace the parts that are worn or damaged.

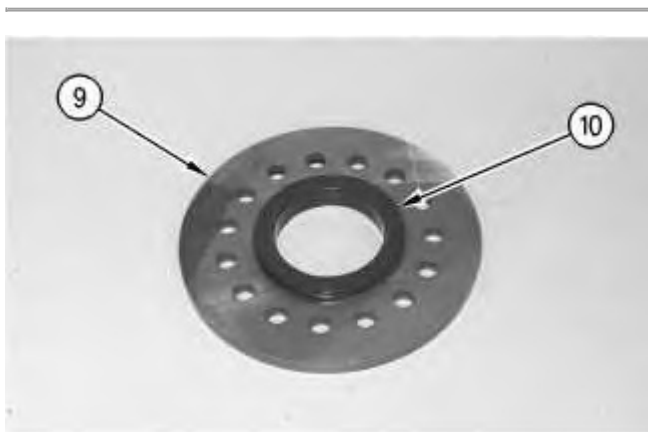

Illustration 1

g00818840

2. Use Tooling (G) to install ring (10) in retainer (9).

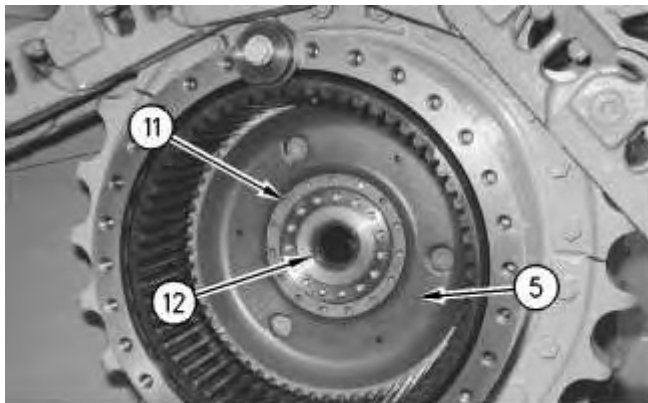

Illustration 2

g00818848

3. Use Tooling (G) to install lip seal (12) in the hub. The lip of the seal must be toward the inside of the hub. Place clean oil on the lip of the seal.
4. Install pins (11) in hub (5).

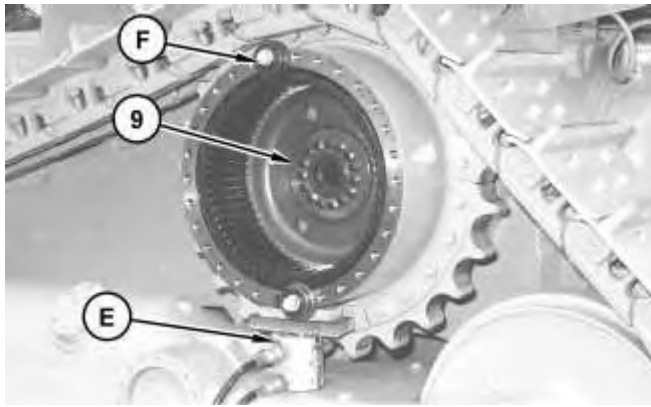

Illustration 3

g01266255

5. Place retainer (9) in position on the hub, and install the bolts that hold the hub in place. Evenly tighten the bolts to a torque of $135 \pm 15 \text{ N}\cdot\text{m}$ ($100 \pm 11 \text{ lb ft}$).
6. Remove Tooling (E) and Tooling (F) from the final drive.

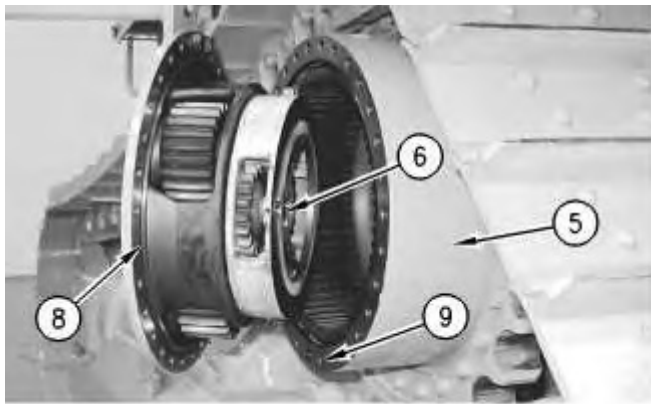

Illustration 4

g00818868

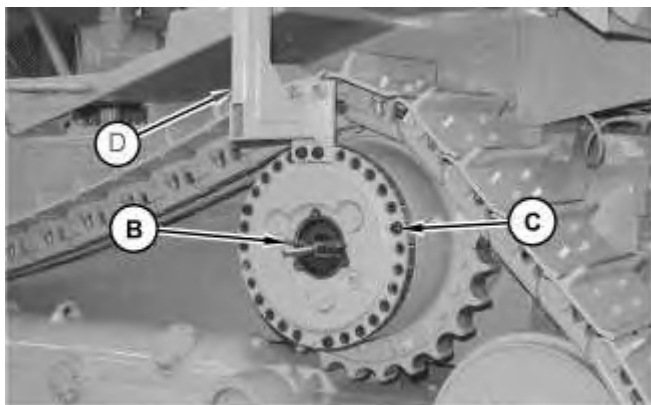

Illustration 5

g01266265

7. Place inner sun gear (6) in position in the planetary carriers, and install Tooling (B) in order to hold the sun gear in place.

8. Install large O-ring seal (8) and small O-ring seal (9).
9. Attach a suitable lifting device and Tooling (D) to the planetary carrier, as shown.
10. Place the planetary carrier in position on hub (5). Align the gears, and slide the planetary carrier in the hub. Push the planetary carrier into the hub until the planetary carrier is approximately 25.4 mm (1.00 inch) from the hub.
11. Install Tooling (C) to a depth of 25.4 mm (1.00 inch) in order to support the planetary carrier, as shown. Remove Tooling (D).

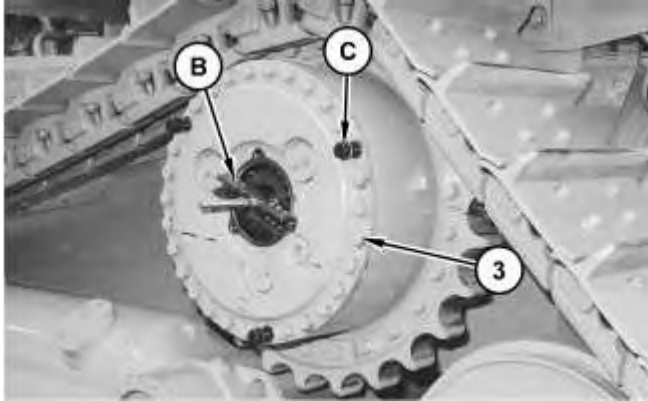

Illustration 6

g01266269

12. Install bolts (3). Remove Tooling (C), and install the last three bolts that hold the planetary carrier to the hub. Tighten bolts (3) to a torque of 475 ± 50 N·m (350 ± 37 lb ft).
13. Remove Tooling (B).



Illustration 7

g01266283

14. Use Tooling (A) to install the outer axle. Be sure that the thrust button that is located between the inner axle and the outer axle is installed in the end of the outer axle.
-

Thank you so much for reading.
Please click the “Buy Now!”
button below to download the
complete manual.



After you pay.

You can download the most
perfect and complete manual in
the world immediately.

Our support email:

ebooklibonline@outlook.com