



Service Repair Manual

Models

**M325C MH WHEELED
EXCAVATOR**

Product: WHEELED EXCAVATOR

Model: M325C MH WHEELED EXCAVATOR XJA

Configuration: M325C Material Handler XJA00001-UP (MACHINE) POWERED BY 3126B Engine

Disassembly and Assembly M325C Material Handler Machine Systems

Media Number -REN7163-01

Publication Date -01/10/2007

Date Updated -24/10/2007

i02233131

Swing Drive - Assemble

SMCS - 5459-016

Assembly Procedure

Table 1

Required Tools			
Tool	Part Number	Part Description	Qty
A	138-7573	Link Bracket	2
B	5P-5197	Pliers	1
E	138-7574	Link Bracket	2
F	138-7575	Link Bracket	3
G	5P-3931	Anti-Seize Compound	1
H	1U-8846	Gasket Sealant	1
J	9S-3263	Thread Lock Compound	1
K	1P-0520	Driver Gp	1

Note: Cleanliness is an important factor. Before assembly, all parts should be thoroughly cleaned in cleaning fluid. Allow the parts to air dry. Wiping cloths or rags should not be used to dry parts. Lint may be deposited on the parts which may cause later trouble. Inspect all parts. If any parts are worn or damaged, use new parts for replacement.



Illustration 1

g01126093

1. Use Tooling (K) to install lip seals (28) and O-ring seal (29) in bearing cage (27) .

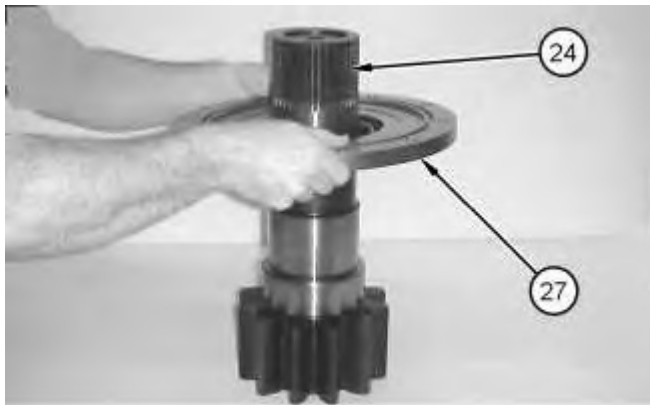
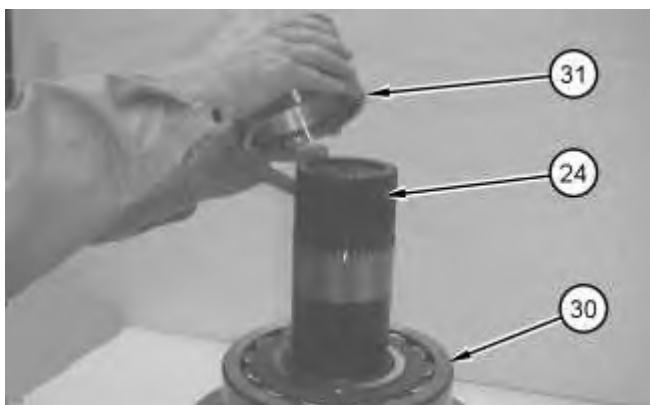

Illustration 2

g01126367

Note: Lubricate the seals and the seal surface of the shaft with the lubricant that is being sealed prior to installation of bearing cage (27) .

2. Install bearing cage (27) on pinion shaft (24) .



3. Raise the temperature of bearing (30). Install bearing (30) on pinion shaft (24) .
4. Install spacer (31) .



Illustration 4

5. Raise the temperature of bearing (32). Install bearing (32) on pinion shaft (24) .



Illustration 5

6. Use Tooling (B) to install retaining ring (23) on pinion shaft (24) and against bearing (32) .
-

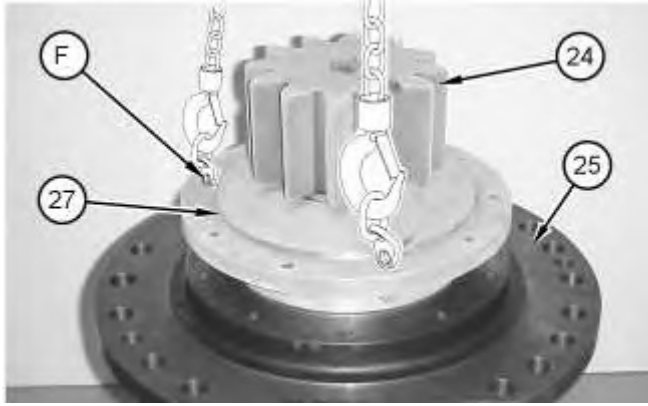

Illustration 6

g01126507

Note: Ensure that bearings (30) and (32) are aligned while pinion shaft (24) is positioned.

7. Apply Tooling (G) to the inside diameter of swing drive housing (25) .
8. Attach Tooling (F) and a suitable lifting device to pinion shaft (24) .
9. Lower the temperature of pinion shaft (24) .
10. Install pinion shaft (24) in swing drive housing (25). The weight of pinion shaft (24) is approximately 50 kg (110 lb).
11. Remove Tooling (F) and the lifting device from pinion shaft (24). Attach Tooling (E) and a suitable lifting device to swing drive housing (25). The combined weight of swing drive housing (25), pinion shaft (24), and bearing cage (27) is approximately 151 kg (333 lb).
12. Lift the swing drive vertically. Use a hammer and a drift to align bearing (30) in the lower bore of swing drive housing (25). When the bearing is properly aligned in the bore, pinion shaft (24) will drop into the proper position within swing drive housing (25) .

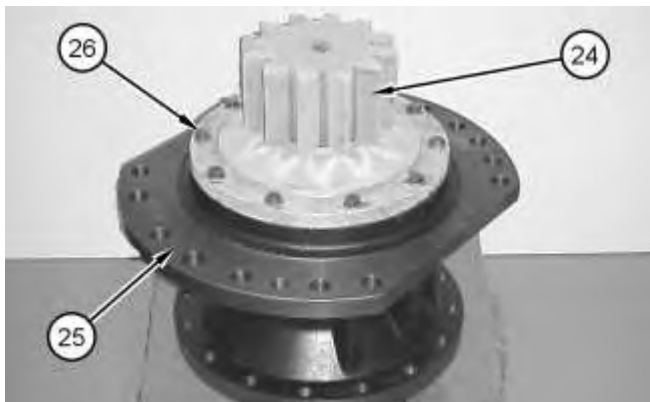

Illustration 7

g01126601

13. Apply Tooling (H) on the threads of bolts (26) .
14. Install bolts (26) .

Thank you so much for reading.
Please click the “Buy Now!”
button below to download the
complete manual.



After you pay.

You can download the most
perfect and complete manual in
the world immediately.

Our support email:

ebooklibonline@outlook.com