



Service Repair Manual

Models

M325D L MH EXCAVATOR

Product: EXCAVATOR

Model: M325D L MH EXCAVATOR KGG

Configuration: M325D L Material Handler KGG00001-01999 (MACHINE) POWERED BY C7 Engine

Disassembly and Assembly M325D Material Handler Machine Systems

Media Number -REN9719-02

Publication Date -01/03/2011

Date Updated -16/03/2011

i02229835

Swing Drive - Disassemble

SMCS - 5459-015

Disassembly Procedure

Table 1

Required Tools			
Tool	Part Number	Part Description	Qty
A	138-7573	Link Bracket	2
B	5P-5197	Retaining Ring Pliers	1
C	1P-0510	Driver Gp	1
D	1U-6213	Sleeve	1
E	138-7574	Link Bracket	2

Start By:

- A. Remove the swing drive. Refer to Disassembly and Assembly, "Swing Drive - Remove".

NOTICE

Care must be taken to ensure that fluids are contained during performance of inspection, maintenance, testing, adjusting and repair of the product. Be prepared to collect the fluid with suitable containers before opening any compartment or disassembling any component containing fluids.

Refer to Special Publication, NENG2500, "Caterpillar Tools and Shop Products Guide" for tools and supplies suitable to collect and contain fluids on Caterpillar products.

Dispose of all fluids according to local regulations and mandates.

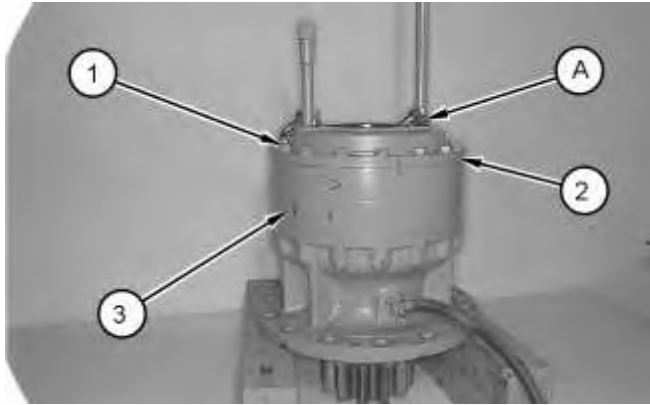

Illustration 1

g01124881

1. Position swing drive (3) on suitable blocking. The weight of swing drive (3) is approximately 310 kg (683 lb).
2. Remove bolts (1) from cover (2) .
3. Attach Tooling (A) to cover (2) .

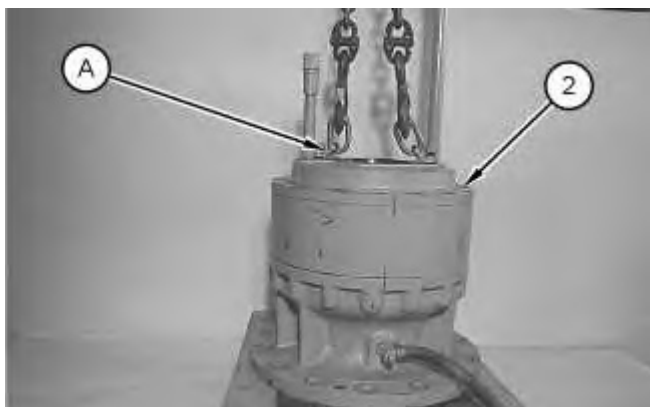

Illustration 2

g01125185

4. Use Tooling (A) and a suitable lifting device to remove cover (2) .
-



Illustration 3

g01125227

5. Use a suitable lifting device or two people to remove carrier assembly (4). The weight of carrier assembly (4) is approximately 23 kg (50 lb).

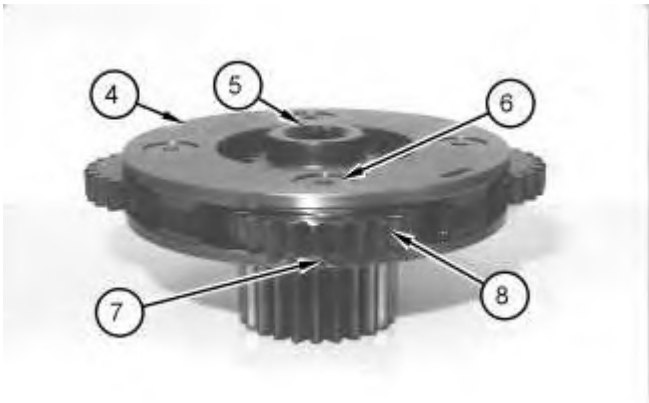

Illustration 4

g01125347

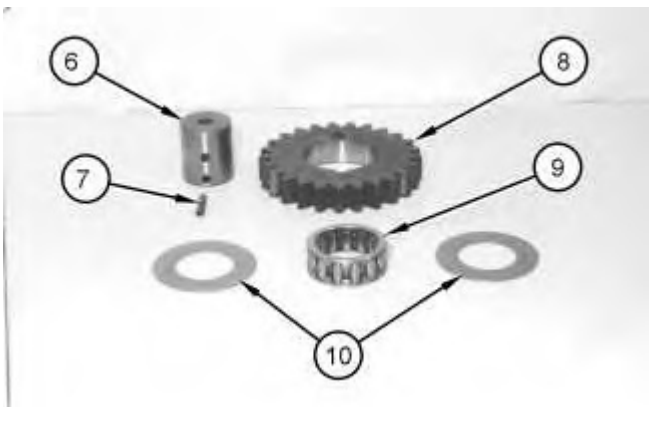

Illustration 5

g01125464

6. Remove sun gear (5) from carrier assembly (4) .

7. Drive pin (7) into shaft (6) .
8. Remove shaft (6), thrust washers (10), and gear (8) .
9. Remove bearing (9) from gear (8) .
10. Remove pin (7) from shaft (6) .
11. Repeat Steps 6 through 10 in order to remove the other three planetary gears from carrier assembly (4) .

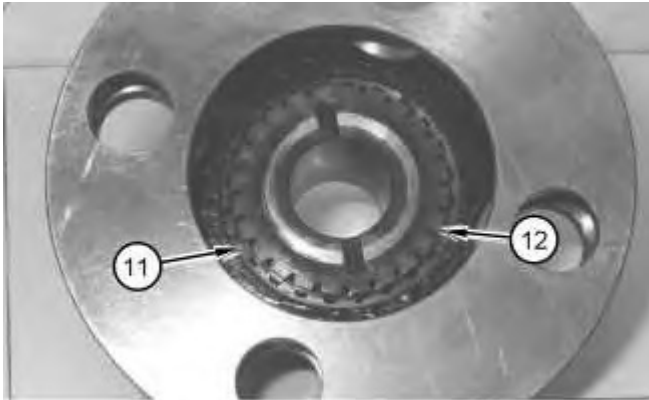

Illustration 6

g01125481

12. Remove retaining ring (11). Remove gear (12) .

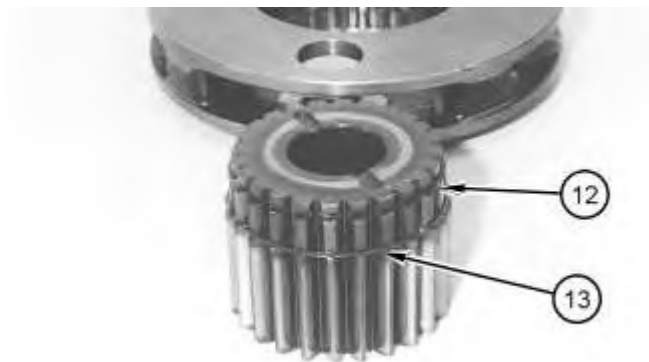

Illustration 7

g01125491

13. Remove retaining ring (13) from gear (12) .
-

Thank you so much for reading.
Please click the “Buy Now!”
button below to download the
complete manual.



After you pay.

You can download the most
perfect and complete manual in
the world immediately.

Our support email:

ebooklibonline@outlook.com