

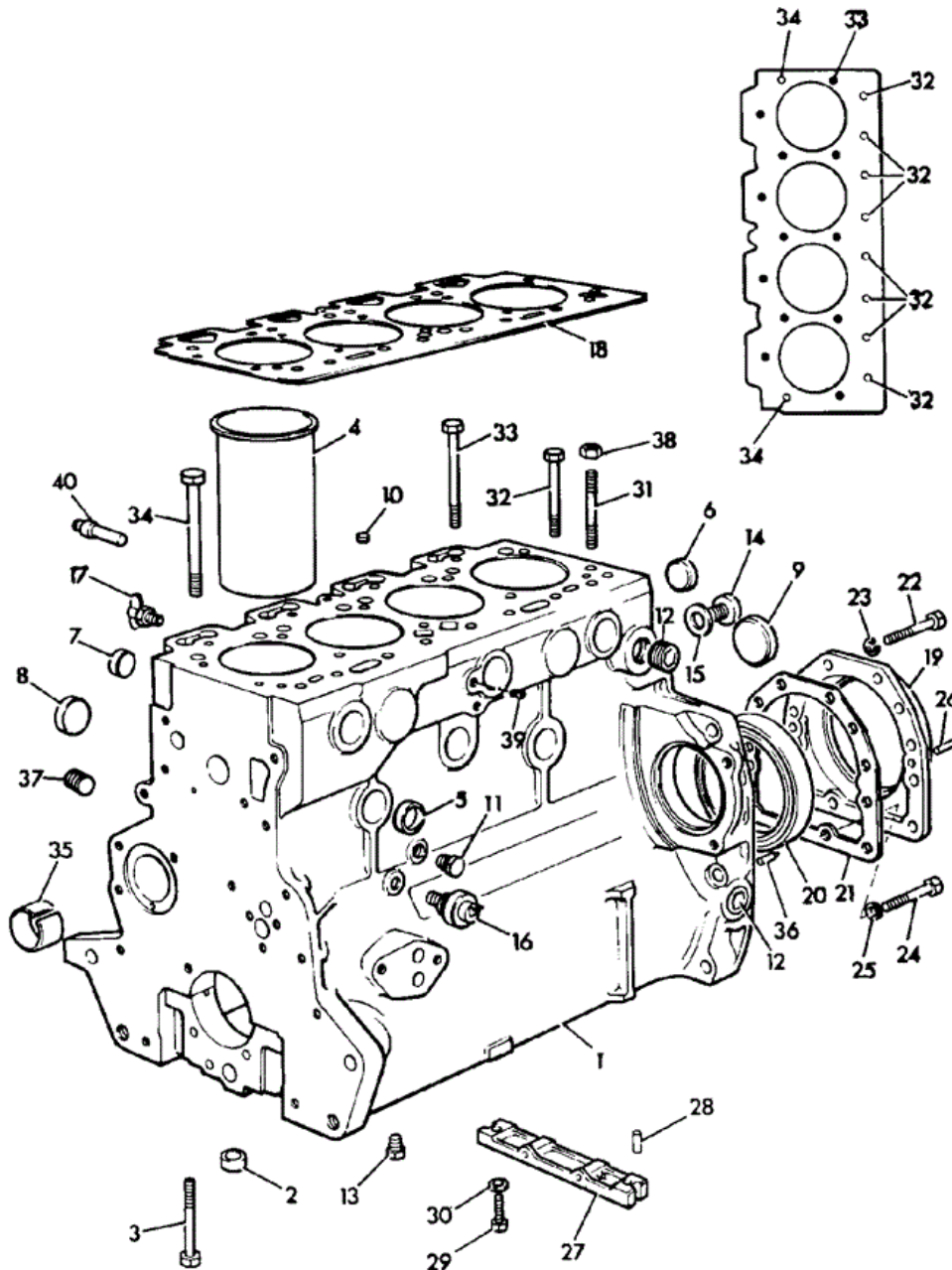

9802/7600 L1-1-1 BLOCK ASSEMBLY LD BUILD



064542

Item	Part #	Change No	Description	Usage Code	QTY
1	02/101583	<EU027630M	Block assembly, cylinder <i>Includes items 2.3.4.5.6.7 & 35</i> <i>See Note 1</i>		1

1	02/101821	Superseded	Block assembly Cylinder <i>See Note 1 Includes items 2.3.4.5.6.7.35 & 40</i>	1
1	N.S.P.		None serviced part <i>Refer to Service Workshop Manual See Note 2</i>	1
1	02/101944		Block assembly cylinder <i>Also READ item 8 footnote on frame L1-3-1 See Note 3</i>	1
2	:02/100101		Thimble	10
3	02/100102		Bolt	10
4	:02/100103	<EU106654N	Liner Press fit <i>Flame ringed type</i>	4
4	02/102038	<EU106654N	Liner oversize - 0.010" 0.25mm <i>With flame ring See Note 4</i>	0
4	:02/101758	>EU106655N	Liner Press fit <i>Used only with 02/101944</i>	4
4	02/100206	<EU106654N	Liner Slip fit <i>Flame ringed type</i>	0
4	02/101773	>EU106655N	Liner Slip fit <i>Used only with 02/101944</i>	0
5	:02/100105		Plug core D=32mm	6
6	:02/100105		Plug core D=32mm	2
7	:02/100106	<EU280718S	Plug core D=35mm	4
7	02/200454		Plug core D=38mm	1
8	02/100110		Plug core D=38mm	4
9	02/100107		Plug core D=50mm	1
10	02/100108		Plug	1
11	02/100132		Plug drain <i>Water Drain</i>	3
11	02/100335		Tap drain <i>Alternative</i>	0
12	02/100134		Plug	3
13	02/100133		Plug	1
14	02/100111		Plug	1
15	823/00276		Washer	1
16	701/06500		Switch oil pressure	1
17	02/100132		Plug drain	1
17	02/100335		Tap drain <i>Alternative</i>	1
18	02/100117	<EU106654N	Gasket cylinder head	1
18	02/101879	Superseded	Gasket cylinder head <i>Used only with 02/101944</i>	1
18	02/102037		Gasket cylinder head	1
19	02/101704	Superseded	Housing rear seal	1
19	02/200223	Superseded	Housing rear seal	1
19	02/200523	Superseded	Housing rear seal	1
19	M.S.S		Multi Supersession <i>Part N.L.A use 19A with items 21A,22A,23A,27A</i>	1
19A	02/200958		Housing rear seal	1
20	02/101436		Seal rear oil	1
21	02/100113		Gasket rear seal housing	1
21A	02/200959		Gasket rear seal housing	1
22	1305/0106Z		Bolt 5/16"UNF x 1" long	10
22A	1305/0106Z		Bolt 5/16"UNF x 1" long	2

23	1410/0002Z		Washer (5/16" Small)		10
23A	1410/0002Z		Washer (5/16" Small)		2
24	1381/3106		Capscrew		2
25	02/100307		Washer		2
26	02/100308		Dowel		2
27	02/100104	Superseded	Bridge piece <i>Use with 2 off 02/100327</i>		1
27	M.S.S		Multi Supersession <i>Part N.L.A use 27A with 2 off 02/101791</i>		1
27A	02/101790	Superseded	Bridge piece <i>Included in latest Cyl/Block Assy</i>		1
27A	M.S.S		Multi Supersession <i>Part N.L.A use 27B with 2 off 1305/0104Z</i>		1
27B	02/102034	Superseded	Bridge piece		1
27B	02/102107		Bridge piece		1
28	02/100112		Seal <i>Used only with items 27 & 27A</i>		2
28	****		'See Remark' <i>Sealant used only with 27B, See Service Manual</i>		1
29	826/00759		Bolt		2
30	02/100309		Washer <i>Used only with item 27</i>		2
32	02/100016	<EU027630M	Bolt 89mm		8
32	02/101762		Bolt 103mm		8
33	02/100017	<EU027630M	Bolt 105mm		12
33	02/101761		Bolt 119mm		12
34	02/100310	<EU027630M	Bolt 125mm		2
34	02/101760		Bolt 140mm		2
35	:02/192001		Bush camshaft <i>Included in Cyl/Block Assy</i>		1
36	02/100136		Pointer Timing		1
37	02/100138		Plug		1
39	02/101810		Plug		1
40	:02/101827	>EU027631M	Plug <i>Included in latest Cyl/Block Assy</i>		1

Note 1: Fitted with flame ringed liners.

Note 2: Part N.L.A use 02/101944 with 1 off 2102/0604, 02/192076, 02/102037 and 3 off 02/101905.

Note 3: New Block (enlarged bore) uses liners without flame ring, Refer to Service Workshop Manual

Note 4: Used only with Block assembly 02/101821

JCB 9802/7600 L1-2-1 CRANKSHAFT, BEARINGS PISTONS,
 CON-RODS PULLEY & FAN BELT, LD BUILD

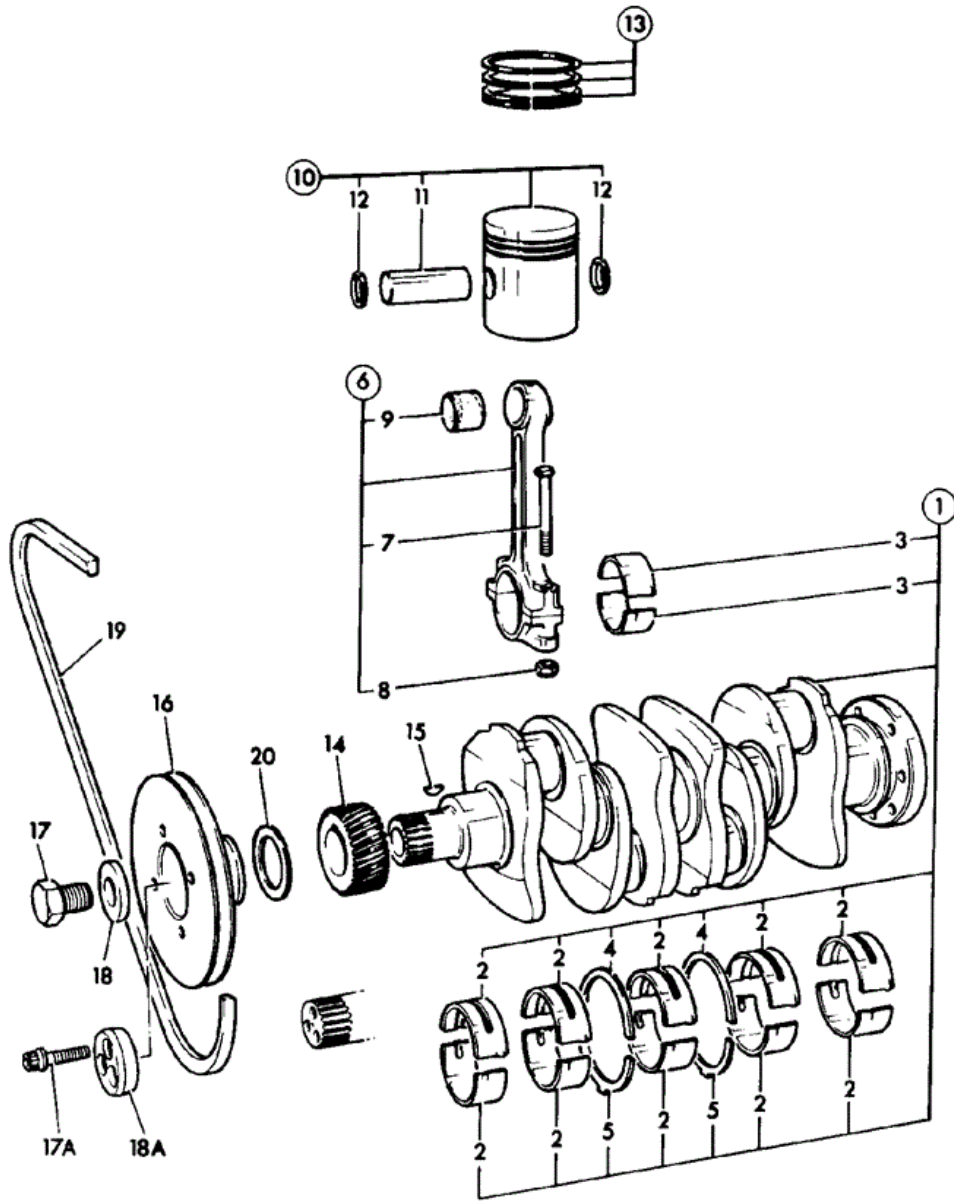

064s12

Item	Part #	Change No	Description	Usage Code	QTY
1	02/100012	Superseded	Crankshaft assembly		1

1	02/101825		Crankshaft assembly <i>Includes items 17A & 18A</i>	P/Ex	1
2	:02/192002		Kit-bearing Main Standard		1
2	02/192003		Kit-bearing Main Undersize - .010inch		0
2	02/192004		Kit-bearing Main Undersize - .020inch		0
2	02/192005		Kit-bearing Main Undersize - .030inch		0
3	:02/192006		Kit-bearing big end standard		1
3	02/192007		Kit-bearing Big end Undersize - .010inch		0
3	02/192008		Kit-bearing Big end Undersize - .020inch		0
3	02/192009		Kit-bearing Big end Undersize - .030inch		0
4	:02/192010	Superseded	Washer thrust top - standard		2
4	:02/192083		Washer thrust top - standard		2
4	02/192011		Washer thrust top-oversize 0.19mm		0
5	:02/192012	Superseded	Washer thrust bottom - standard		2
5	:02/192084		Washer thrust bottom - standard		2
5	02/192013		Washer thrust btm-oversize 0.19mm		0
6	02/101440		Rod assembly Connecting		4
7	:02/100127		Bolt		2
8	:02/100128		Nut		2
9	:02/192015		Bush small end		1
10	02/100007		Piston assembly 5 ring		4
10	02/100008		Piston assembly Oversize - .030inch		0
11	:N.S.P.		None serviced part <i>Gudgeon pin</i>		1
12	:2203/1040		Circlip		2
13	02/101438		Kit-piston ring		4
13	02/100011		Kit-piston ring service <i>For use with part worn bores</i>		0
13	02/100010		Kit-piston ring oversize - .030 inch		0
14	02/190001		Gear crankshaft		1
15	02/100038		Key		1
16	02/101572	<EU978997L	Pulley Spoked Crankshaft		1
16	02/101736		Pulley Crankshaft		1
17	02/101586	<EU071167N	Bolt		1
17A	02/101813		Capscrew		3
18	02/100139	<EU071167N	Washer		1
18A	02/101812		Block Thrust		1
19	02/101566		Belt fan, pair L=1312mm		1
20	02/100178	<EU978997L	Washer		1

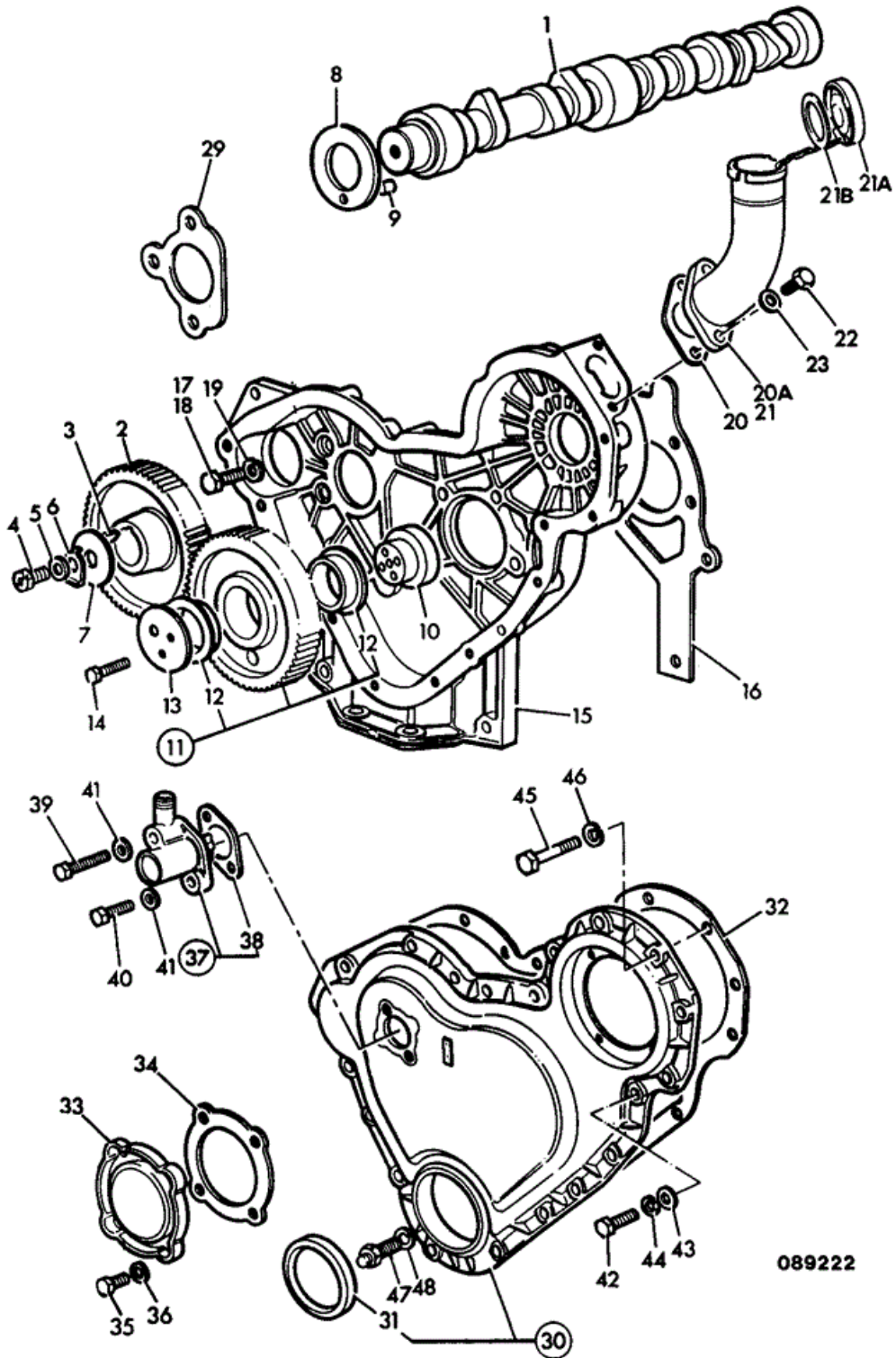

089222

Item	Part #	Change No	Description	Usage Code	QTY
1	02/100040	<EU106654N	Camshaft		1
1	02/101890		Camshaft		1
2	02/190002	<EU106654N	Gear camshaft		1
2	02/190032		Gear camshaft		1
3	02/100038		Key		1

4	02/100312		Bolt		1
5	02/100306		Washer		1
6	02/100305		Washer tab		1
7	02/100313		Plate thrust		1
8	02/192046		Washer thrust		1
8	02/192076		Washer thrust <i>Refer to Service Workshop Manual See Note 1</i>		1
9	2102/0604		Dowel		1
10	02/100041		Hub		1
11	02/190003		Gear Idler		1
12	:02/192016		Bush		2
13	02/100042		Plate		1
14	1305/3218Z	<EU106654N	Bolt		3
14	02/101905		Screw hexagon head		3
15	02/100002		Casing timing		1
16	02/100005	<EU106654N	Gasket timing case		1
16	02/101891		Gasket timing case		1
17	1305/0105Z		Bolt		8
18	1305/0106Z		Bolt 5/16"UNF x 1" long		1
19	823/00268		Washer spring		9
20	02/100140		Gasket		1
21	02/101483		Tube oil filler assembly		1
21A	:02/101484		Cap oil filler		1
21B	:02/100421		Seal		1
22	1305/0104Z		Setscrew (5/16" UNF x 3/4")		2
23	823/00268		Washer spring		2
29	813/00169		Gasket		1
30	02/100944		Cover timing		1
31	:02/101435		Seal front oil		1
32	02/100006	Superseded	Gasket timing cover		1
32	02/102086		Gasket timing cover		1
33	02/100144	Superseded	Cover inspection		1
33	02/101796		Cover Inspection		1
34	02/100145		Gasket		1
35	1305/0103Z		Screw		4
36	823/00268		Washer spring		4
37	02/300113		Drive Tachometer		1
38	:02/100146		Gasket		1
39	1305/3010Z		Bolt <i>1.1/2" Long</i>		1
40	1305/0004Z		Bolt <i>3/4" Long</i>		1
41	823/00267		Washer		2
42	1305/0105Z		Bolt <i>7/8" Long</i>		14
43	823/00263		Washer		4
44	823/00268		Washer spring		10
45	1305/3118Z		Bolt 5/16"UNF x 2.5" long <i>2.1/2" Long</i>		4
46	823/00268		Washer spring		4

Note 1: Fitted only when new type Cylinder block is used with earlier Camshaft, Gear & T/C Gasket.



9802/7600 L1-4-4 FLYWHEEL & HOUSING LD BUILD

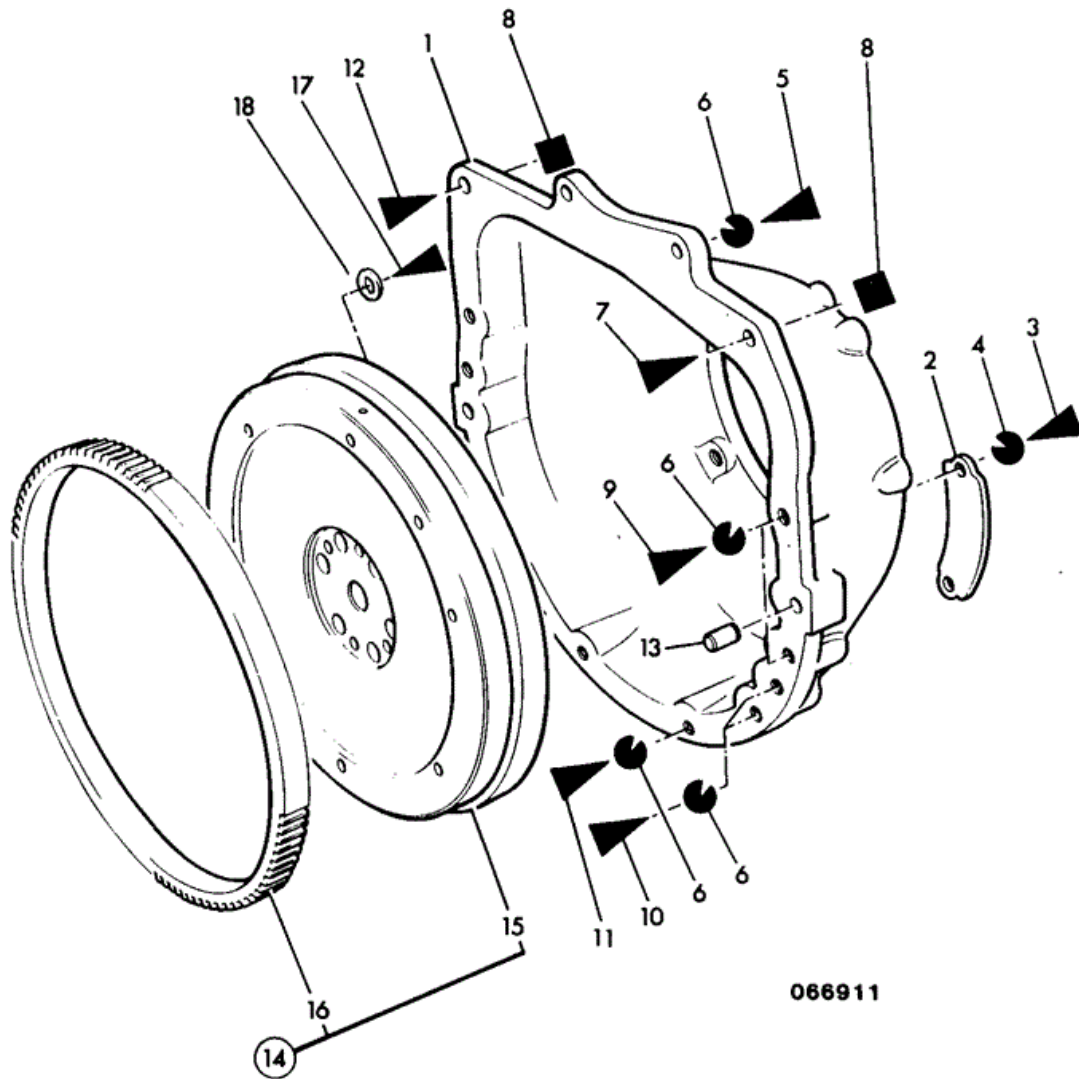

066911

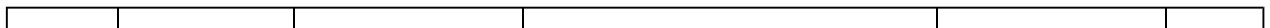

Item	Part #	Change No	Description	Usage Code	QTY
1	121/77701		Housing flywheel		1
2	121/77702		Cover		1
3	1305/1804		Bolt		2
4	1416/0007		Washer		2
5	1305/4818		Bolt		2
6	1416/0007		Washer		13
7	1305/3330		Bolt		1
8	1340/0304		Nut		2
9	1305/4818		Bolt		5
10	1305/4822		Bolt		4
11	1305/4814		Bolt		2
12	1305/3314		Bolt		1
13	02/101370		Dowel		2
14	02/101585		Flywheel assembly		1
15	:N.S.P.		None serviced part		1
16	:02/100078		Gear starter ring		1
17	1305/0407		Bolt		6
18	02/100614		Washer		6



9802/7600 L1-6-6 ENGINE MOUNTINGS LD BUILD

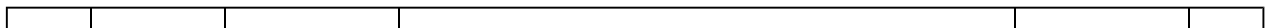
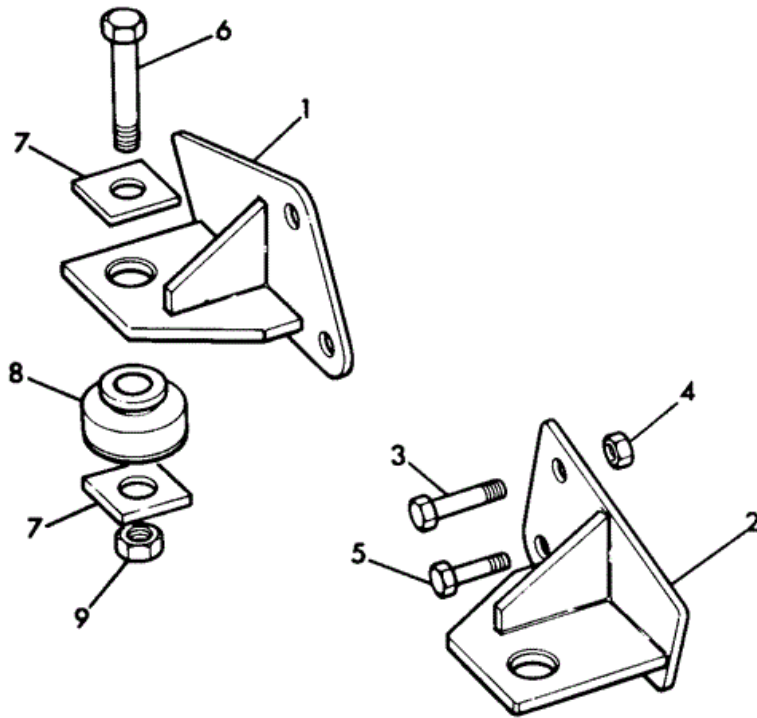

Item	Part #	Change No	Description	Usage Code	QTY
1	190/25600		Bracket engine mounting left hand		1
2	190/25500		Bracket engine mounting right hand		1
3	1315/3716Z		Bolt M16 x 70mm		2
4	1370/0603Z		Nut lock M16		2
5	1315/0710Z		Setscrew		2
6	1305/3424Z		Bolt 1/2" x 3.1/4" long		2
7	111/15709		Washer		4
8	111/30101		Mounting metalastik		2
9	1340/0403Z		Nut lock		2

Thank you so much for reading.
Please click the “Buy Now!”
button below to download the
complete manual.



After you pay.

You can download the most
perfect and complete manual in
the world immediately.

Our support email:

ebooklibonline@outlook.com