

**JOHN DEERE**  
**AG & TURF DIVISION**

---

**ZTrak™**  
**Z900B, Z900M, Z900R Series**

OMTCU35848 D3

**OPERATOR'S MANUAL**



**JOHN DEERE**

**⚠ WARNING:** The Engine Exhaust from this product contains chemicals known to the State of California to cause cancer, birth defects or other reproductive harm.

California Proposition 65 Warning

North American Version  
Printed in U.S.A.

# Introduction

---

## Thank You for Purchasing a John Deere Product

We appreciate having you as a customer and wish you many years of safe and satisfied use of your machine.

## Using Your Operator's Manual

This manual is an important part of your machine and should remain with the machine when you sell it.

Reading your operator's manual will help you and others avoid personal injury or damage to the machine. Information given in this manual will provide the operator with the safest and most effective use of the machine. Knowing how to operate this machine safely and correctly will allow you to train others who may operate this machine.

If you have an attachment, use the safety and operating information in the attachment operator's manual along with the machine operator's manual to operate the attachment safely and correctly.

This manual and safety signs on your machine may also be available in other languages (see your authorized dealer to order).

Sections in your operator's manual are placed in a specific order to help you understand all the safety messages and learn the controls so you can operate this machine safely. You can also use this manual to answer any specific operating or servicing questions. A convenient index located at the end of this book will help you to find needed information quickly.

The machine shown in this manual may differ slightly from your machine, but will be similar enough to help you understand our instructions.

RIGHT-HAND and LEFT-HAND sides are determined by facing in the direction the machine will travel when going forward. When you see a broken line (-----), the item referred to is hidden from view.

Before delivering this machine, your dealer performed a predelivery inspection to ensure best performance.

## Special Messages

Your manual contains special messages to bring attention to potential safety concerns, machine damage as well as helpful operating and servicing information. Please read all the information carefully to avoid injury and machine damage.



**CAUTION: Avoid injury! This symbol and text highlight potential hazards or death to the operator or bystanders that may occur if the hazards or procedures are ignored.**

**IMPORTANT: Avoid damage! This text is used to tell the operator of actions or conditions that might result in damage to the machine.**

***NOTE: General information is given throughout the manual that may help the operator in the operation or service of the machine.***

# Product Identification

## Record Identification Numbers

ZTrak™ Z915B (Z900B Series), Z920M, Z925M EFI, Z925M EFI Flex Fuel, Z930M, Z930M EFI (Z900M Series), Z920R, Z930R, Z950R, Z960R, Z970R (Z900R Series)

PIN (010001-)

If you need to contact an Authorized Service Center for information on servicing, always provide the product model and serial number.

You will need to locate the model and serial number for the machine and for the engine of your machine and record the information in the spaces provided below.

DATE OF PURCHASE:

\_\_\_\_\_

DEALER NAME:

\_\_\_\_\_

DEALER PHONE:

\_\_\_\_\_

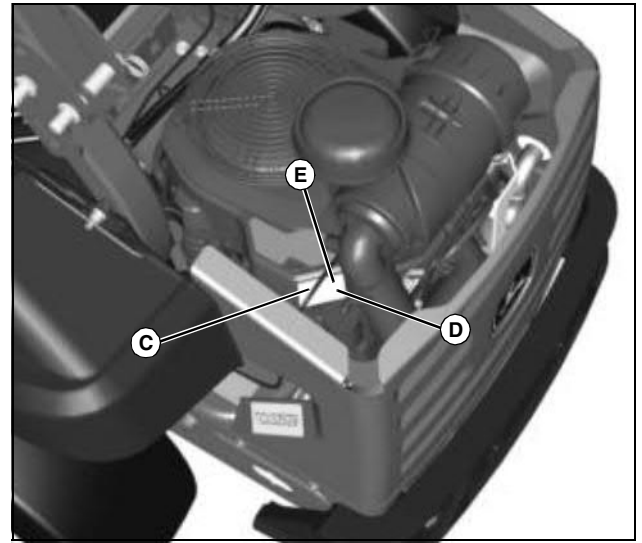

MX51852

### Picture Note: Kohler Engine

ENGINE MODEL NUMBER (C):

-----  
ENGINE SPECIFICATION NUMBER (D):

-----  
ENGINE SERIAL NUMBER (E):

-----

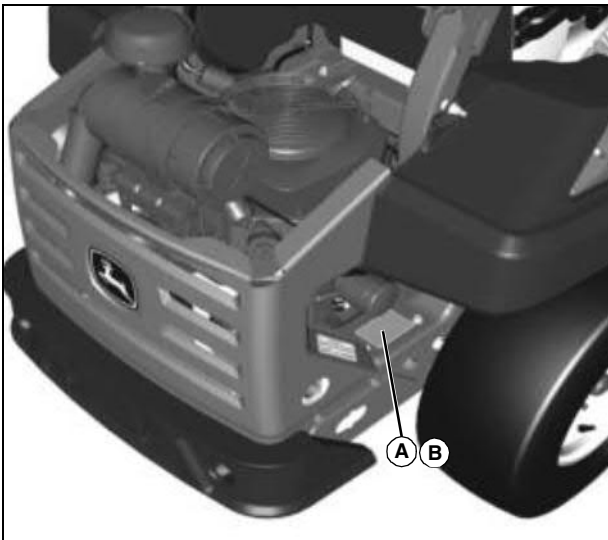

MX51851

PRODUCT MODEL NUMBER (A):

-----  
PRODUCT IDENTIFICATION NUMBER (B):

-----

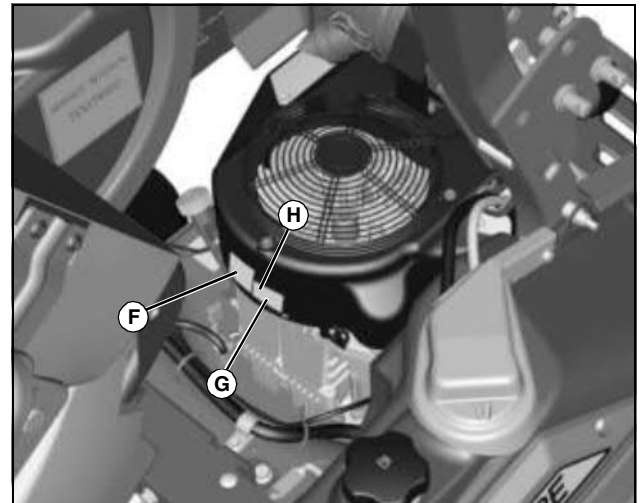

MX51909

### Picture Note: Kawasaki Engine

ENGINE MODEL NUMBER (F):

-----  
ENGINE SPECIFICATION NUMBER (G):

-----  
ENGINE SERIAL NUMBER (H):

-----

# Table of Contents

---

Safety Labels .....	1
Safety Labels .....	6
Safety .....	11
Operating - Controls .....	19
Operating .....	21
Replacement Parts .....	41
Service Intervals .....	42
Service Lubrication .....	44
Service Engine .....	46
Service Transmission .....	62
Service Steering & Brakes .....	68
Service Mower .....	71
Service Electrical .....	75
Service Miscellaneous .....	80
Troubleshooting .....	84
Storage .....	96
Specifications .....	98
Warranty .....	106
Index .....	108

Original Instruction

All information, illustrations and specifications in this manual are based on the latest information at the time of publication. The right is reserved to make changes at any time without notice.

COPYRIGHT© 2013

Deere & Co.

John Deere Ag & Turf Division

All rights reserved

Previous Editions

COPYRIGHT©

OMTCU35848 D3 -

# Safety Labels

## Safety Label Location (Text)

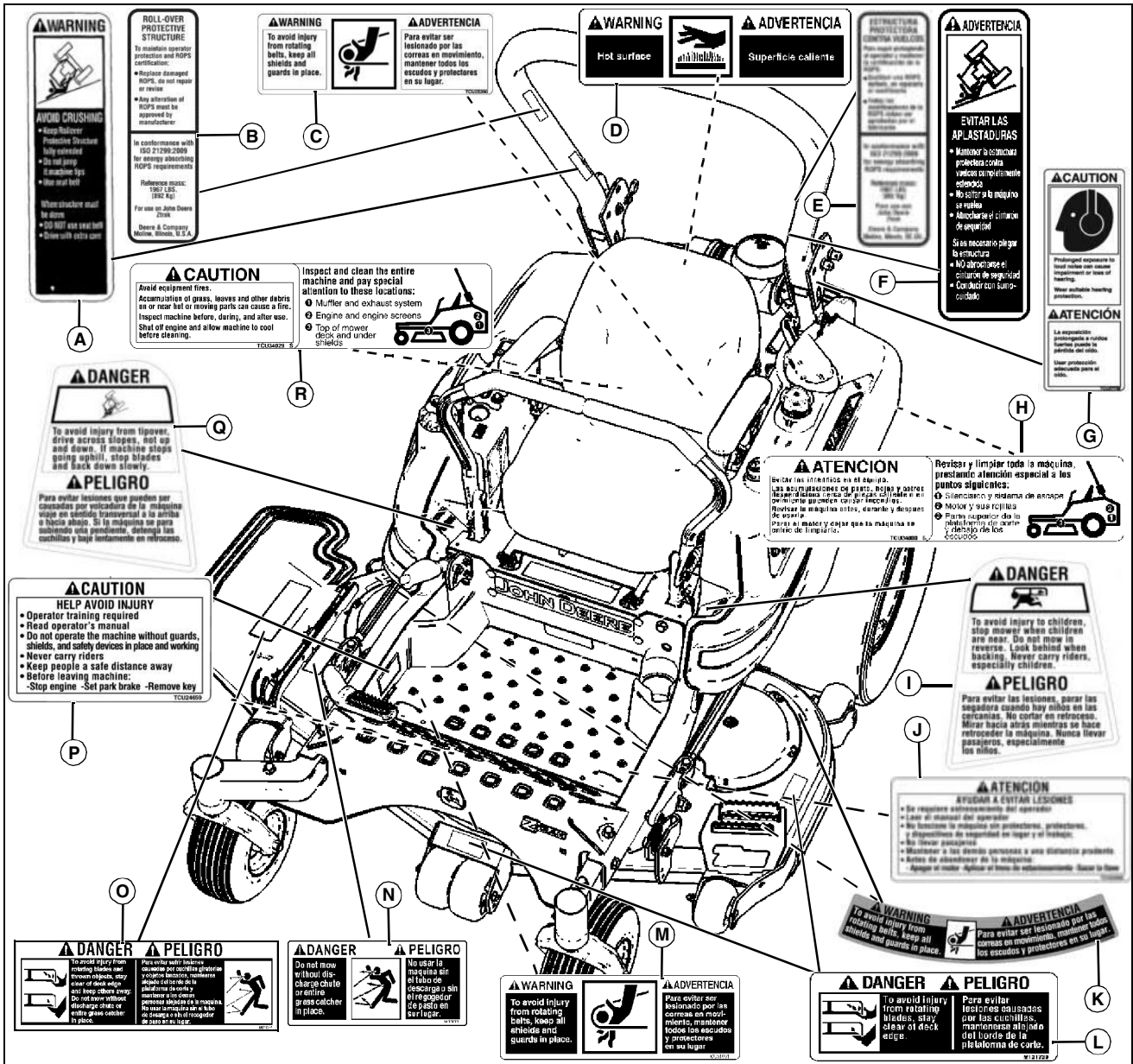

MX52183

Picture Note: Use label number listed in table below to locate complete text of safety label message following this illustration.

- |   |  |
|---|--|
| <p><b>A - AVOID CRUSHING</b></p> <p><b>B - ROLL-OVER PROTECTIVE STRUCTURE</b></p> <p><b>C - ROTATING BELT</b></p> <p><b>D - HOT SURFACES</b></p> <p><b>E - ROLL-OVER PROTECTIVE STRUCTURE (Spanish)</b></p> <p><b>F - AVOID CRUSHING (Spanish)</b></p> <p><b>G - HEARING PROTECTION</b></p> <p><b>H - PREVENT EQUIPMENT FIRES (Spanish)</b></p> | <p><b>I - AVOID INJURY TCU31665</b></p> <p><b>J - HELP AVOID INJURY (Spanish)</b></p> <p><b>K - ROTATING BELT</b></p> <p><b>L - ROTATING BLADES</b></p> <p><b>M - ROTATING BELT</b></p> <p><b>N - THROWN OBJECTS</b></p> <p><b>O - ROTATING BLADES AND THROWN OBJECTS</b></p> <p><b>P - HELP AVOID INJURY</b></p> <p><b>Q - AVOID TIPPING</b></p> <p><b>R - PREVENT EQUIPMENT FIRES TCU34029</b></p> |
|---|--|

Thank you so much for reading.  
Please click the “Buy Now!”  
button below to download the  
complete manual.



After you pay.

You can download the most  
perfect and complete manual in  
the world immediately.

Our support email:

[ebooklibonline@outlook.com](mailto:ebooklibonline@outlook.com)