

Section: ENGINE  
CRANKCASE

Fig.	P/n	QTY	Name
<b>Notes:</b>			
[1106]			
1	0.066.1120.0/20	6	engine cylinder 3528 <= X 100HP 1463 <= X 110HP 1764 <= X 130HP
1	0.066.1120.0/30	6	engine cylinder => 3529 - 3642 <= X 100HP => 1464 - 1965 <= X 110HP => 1765 - 1802 <= X 130HP
1	0.066.1120.0/60	6	engine cylinder => 3643 X 100HP => 1966 X 110HP => 1803 X 130HP
2	2.1519.096.0/20	18	special oil seal 107.67x1.78 3642 <= X 100HP 1965 <= X 110HP 1802 <= X 130HP
2	2.1539.193.0	12	special oil seal 107.62x2.62 => 3643 X 100HP => 1966 X 110HP => 1803 X 130HP
3	2.1559.188.2	6	bush 11.4 x 14 x 16
4	2.0432.003.7	18	stud bolt m 8 p.1.25 / p.1 x 20
5	2.0112.305.2	1	screw m 10 p.1.5 x 16
6	2.1470.006.2	1	lock washer 10
7	2.0312.219.2	2	screw m 8 p.1.25x65
8	2.1470.004.2	2	lock washer 8
9	0.065.1143.3	1	body 1026 <= X 100HP 1027 <= X 110HP 1020 <= X 130HP
9	0.065.1143.3/10	1	body => 1027 - (...) <= X 100HP => 1028 - (...) <= X 110HP => 1021 - (...) <= X 130HP
10	2.6850.006.0	1	clamp 18-28 1026 <= X 100HP 1027 <= X 110HP 1020 <= X 130HP
10	2.6859.072.2	1	clamp => 1027 - (...) <= X 100HP => 1028 - (...) <= X 110HP

Section: ENGINE

## CRANKCASE

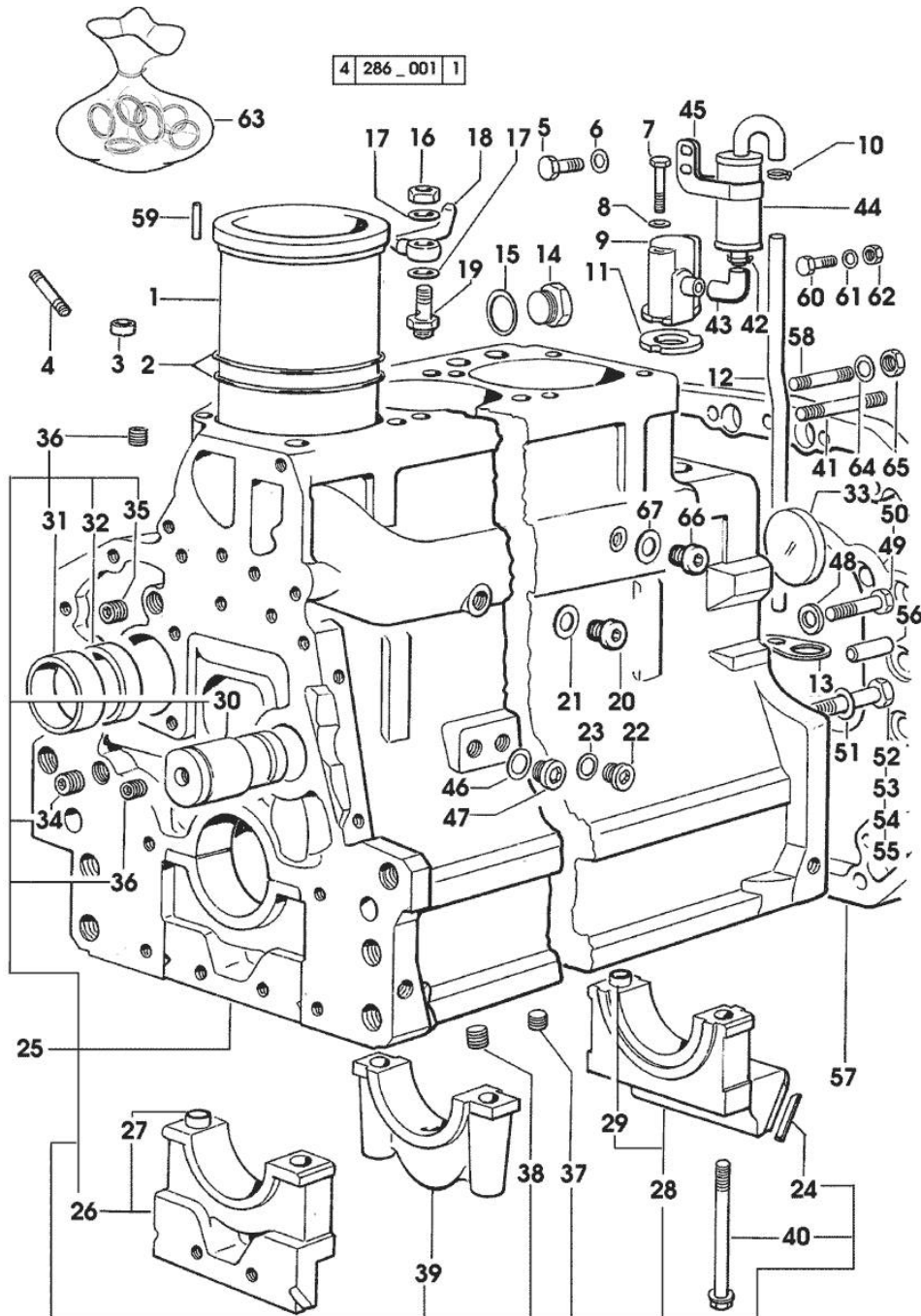
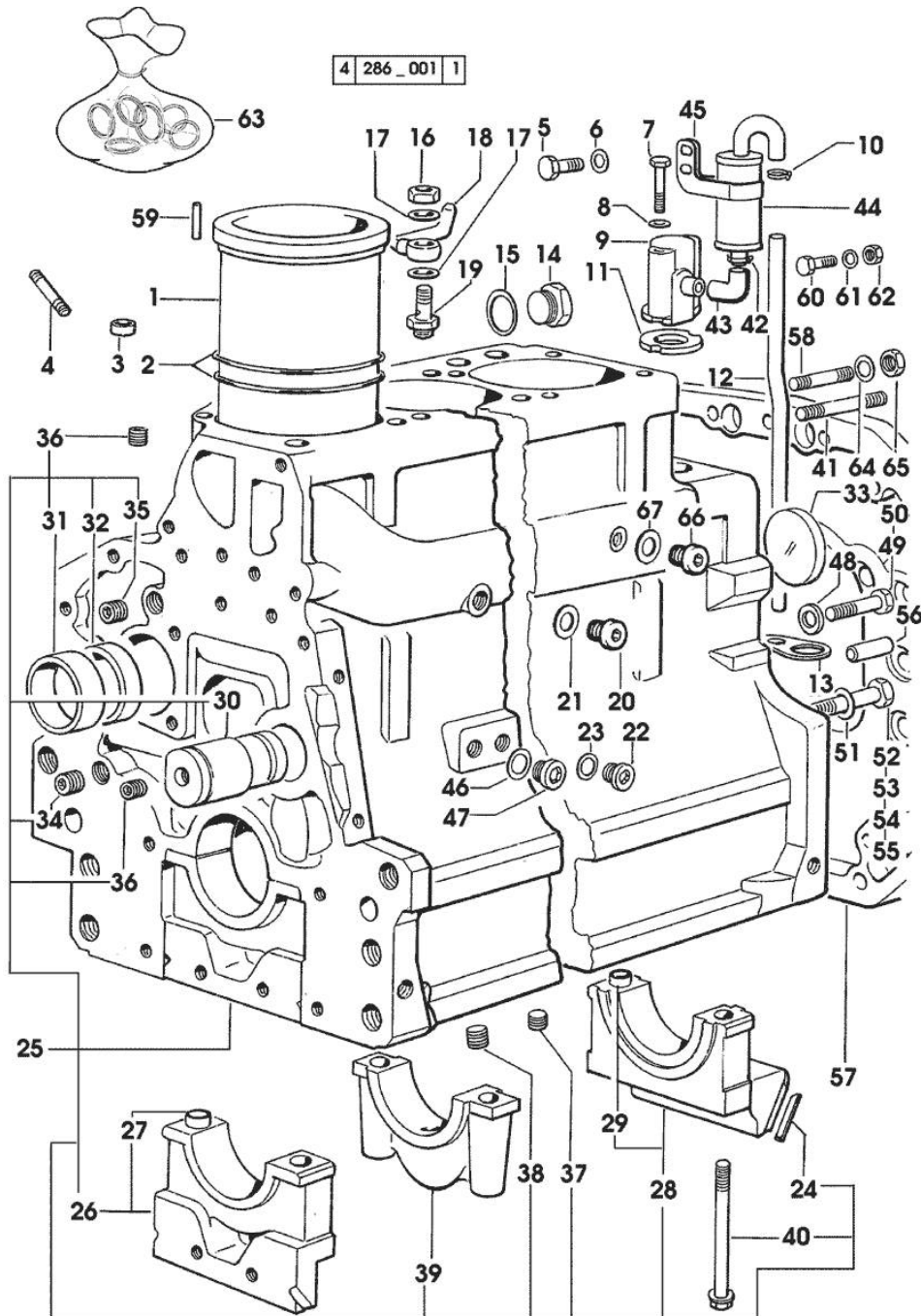

Fig.	P/n	QTY	Name
			=> 1021 - (...) <= X 130HP
11	0.065.1156.0	1	gasket
12	0.065.1155.0	1	old part number 1026 <= X 100HP 1027 <= X 110HP 1020 <= X 130HP
12	0.065.1155.0/10		tube => 1027 - (...) <= X 100HP => 1028 - (...) <= X 110HP => 1021 - (...) <= X 130HP
13	0.065.1157.0	1	bracket
14	2.3199.405.2	1	plug m 28 p.1.5
15	2.1539.047.0	1	special oil seal 26.7x1.78
16	2.1099.108.2	6	special nut m 10 p.1
17	2.1560.006.0	12	gasket 10.2 x 16
18	0.086.1550.2	6	sprayer nozzle
19	0.065.1160.3/10	6	old part number
20	2.3199.292.0	1	plug 1/4" gas
21	2.1560.010.0	1	gasket 14.2 x 20
22	2.3120.001.4	2	plug m 18 p.1.5
23	2.1560.014.0	1	washer 18.2 x 24
24	0.066.1152.0/10	4	gasket
25	0.075.1110.6/20	1	crankcase * 3642 <= X 100HP * 1965 <= X 110HP * 1802 <= X 130HP - N.6 066.1120.0/50 - N.12 2.1539.193.0
26	0.065.1112.7	1	support
27	2.1699.165.0	2	bush 12.3x15x16
28	0.065.1116.3	1	support
29	2.1699.165.0	4	bush 12.3x15x16
30	0.066.1151.0	1	pin
31	0.065.1141.0	1	special bushing 59X55X30
32	0.065.1140.0	6	special bushing 59X55X20
33	2.3179.012.0	1	plug 60
34	2.3130.003.1	7	plug 3/8" gas
35	2.3130.002.1	2	plug 1/4" gas
36	2.3130.001.1	14	plug 1/8" gas
37	2.1324.011.0	1	plug
38	2.3131.006.0	1	plug m 22 x 1.5
39	0.065.1114.0/10	5	support
40	0.065.1117.0	14	screw m 12 x 100
41	2.0432.267.7	6	stud bolt m 12 p.1.75-1.25x60
42	2.6859.073.2	2	clamp

Section: ENGINE  
CRANKCASE

Fig.	P/n	QTY	Name
			=> 1027 - (...) <= X 100HP => 1028 - (...) <= X 110HP => 1021 - (...) <= X 130HP
43	0.065.1166.0	1	sleeve => 1027 - (...) <= X 100HP => 1028 - (...) <= X 110HP => 1021 - (...) <= X 130HP
44	0.065.1165.2	1	sediment bowl => 1027 - (...) <= X 100HP => 1028 - (...) <= X 110HP => 1021 - (...) <= X 130HP
45	2.6859.074.2/10	1	clamp => 1027 - (...) <= X 100HP => 1028 - (...) <= X 110HP => 1021 - (...) <= X 130HP
46	2.1560.017.0	1	gasket 22.2 x 27
47	2.3120.002.4	1	plug m 22 x 1.5
48	2.1599.144.7	4	shoulder ring 12.5x23x4
49	2.0112.429.2	4	screw m 12 p.1.75x100
50	2.0112.433.2	2	screw m 12 p.1.75x120
51	2.1470.008.6	6	lock washer 14
52	2.0112.513.2	11	screw m 14 p.2 x 35
53	2.0312.520.1	2	screw m 14 p.2x70
54	2.0112.533.1	4	screw
55	2.0112.607.2	2	screw m 16 p.2x20
56	2.1651.911.0	4	cylindrical plug
57	0.075.1130.0	1	spacer (...) <=
57	0.078.1130.0/20	1	flange => (...)
58	2.0432.257.7	2	stud bolt m 12 p.1.75 - 1.25 x 30
59	2.1631.205.0	1	roll pin
60	2.0112.005.2	1	screw m 6 p.1 x 16
61	2.1470.002.2	1	lock washer 6
62	2.1011.103.2	1	nut m 6 p.1
63	0.075.0050.6		gasket set - X 100HP - X 110HP - FOR ENGINE MOUNTING
63	0.078.0050.6		gasket set - X 130HP - FOR ENGINE MOUNTING
64	2.1470.007.2	12	lock washer 12
65	2.1011.322.1	6	nut m 12 p.1.25

Section: ENGINE  
CRANKCASE

Fig.	P/n	QTY	Name
66	2.3120.101.0	1	plug m 18 p.1.5 => 3643 X 100HP => 1966 X 110HP => 1803 X 130HP
67	2.1560.014.0	1	washer 18.2 x 24

Section: ENGINE

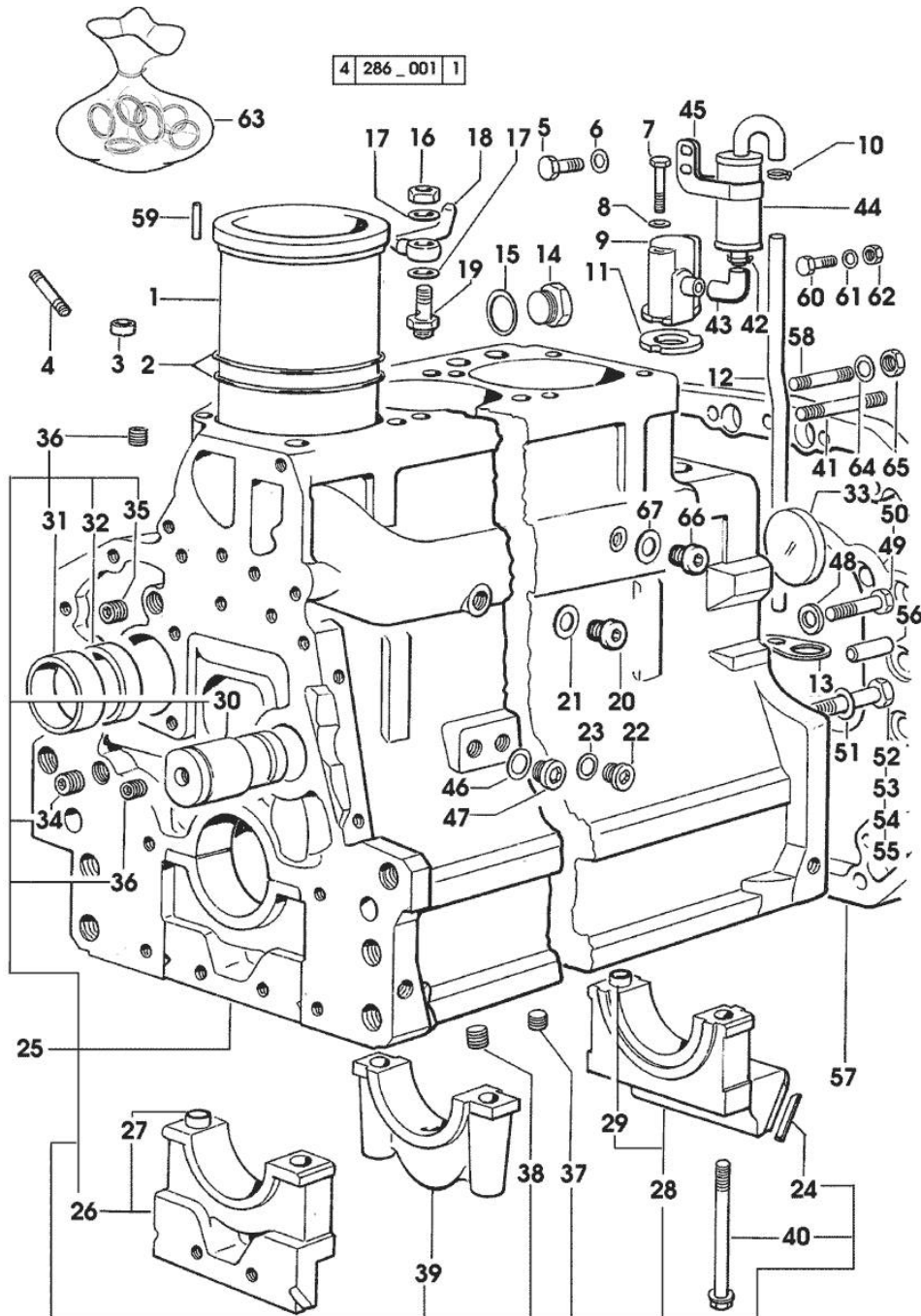
**TIMING CASE**

Fig.	P/n	QTY	Name
------	-----	-----	------

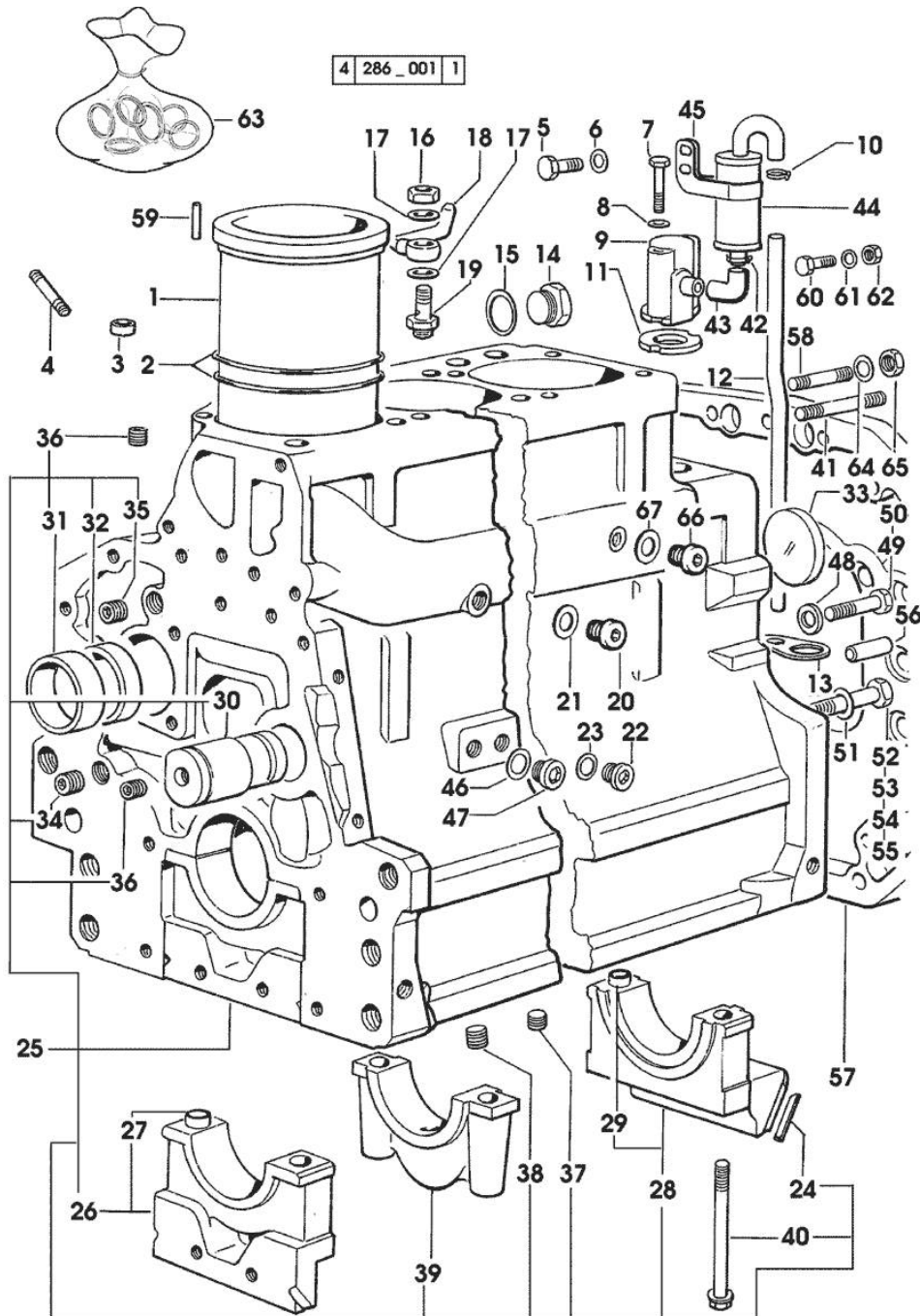
**Notes:**

[1106]

1	0.065.1132.0/60	1	guard
2	0.065.1150.0/30	1	gasket
3	0.065.1152.0	1	gasket
4	0.065.1151.0	1	cover
5	2.1470.004.2	4	lock washer 8
6	2.0112.205.2	2	screw m 8 p.1.25 x 16
7	2.0432.003.7	2	stud bolt m 8 p.1.25 / p.1 x 20
8	2.1011.405.2	2	nut m 8 p.1
9	2.0312.208.2	8	screw m 8 p.1.25 x 25
10	2.1480.014.1	15	washer 8
11	2.0432.003.7	2	stud bolt m 8 p.1.25 / p.1 x 20
13	2.0312.214.2	7	screw m 8 p.1.25 x 40
14	2.1529.141.0	1	special oil seal

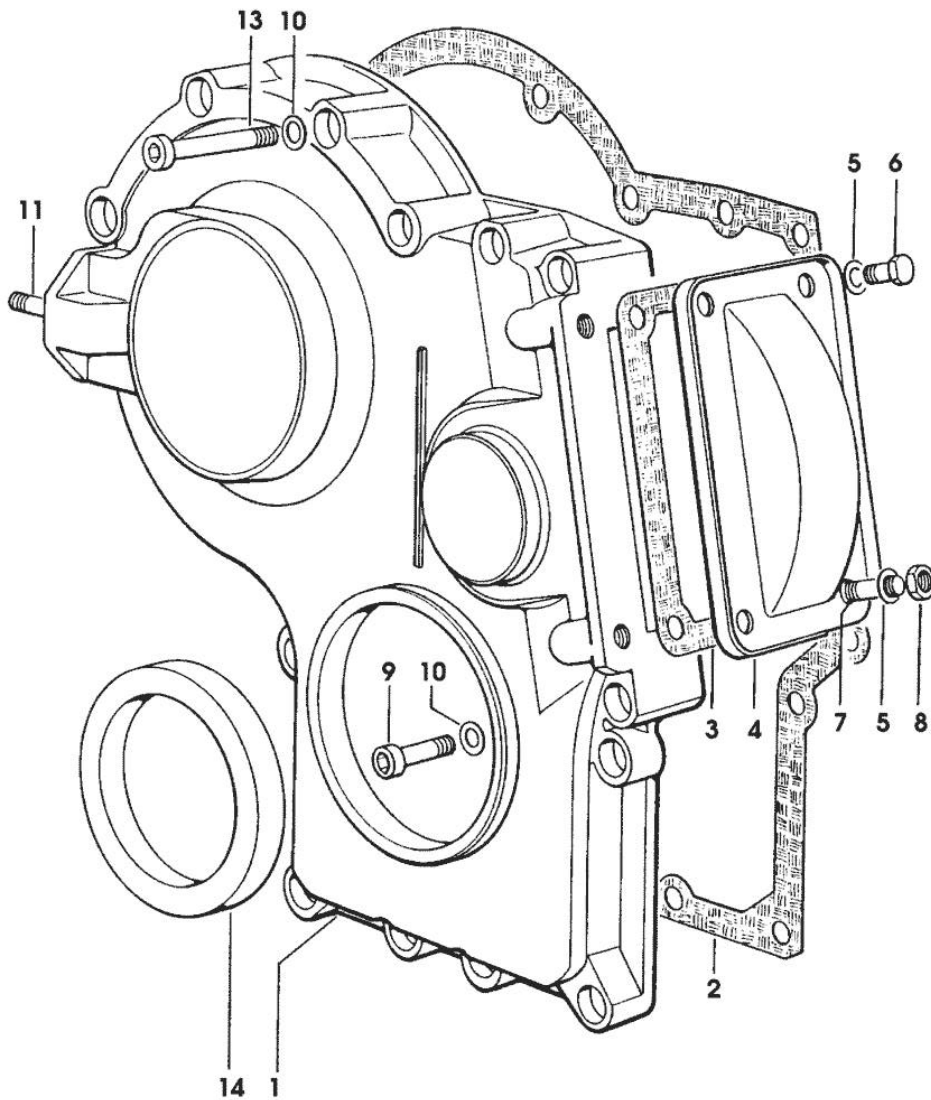

286\_002

Section: ENGINE  
CRANKSHAFT

Fig.	P/n	QTY	Name
------	-----	-----	------

Notes:  
[1106]

1	0.080.1210.0/20	1	crankshaft * (...) <= - N.6 2.3130.001.1
2	2.3130.001.1	6	plug 1/8" gas
3	0.007.0896.0/20	1	hub - A = mm 57 - FOR VISCOUS TYPE => (...) * (...) <= - N.1 007.1010.3
3	0.065.1248.0/30	1	hub - A = mm 47 - FOR RUBBER TYPE (...) <=
4	2.1720.006.0	2	key 4x6.5
5	0.065.1220.3/30	6	engine connecting rod - X 100HP - X 110HP
5	0.078.1220.3/30	6	engine connecting rod - X 130HP
6	2.0399.213.0	12	screw m 12 p.1.25x61.5
7	0.065.1227.0	6	special bushing - X 100HP - X 110HP
7	2.1559.114.0/10	6	special bushing - X 130HP
8	0.075.1241.3	1	flywheel (...) <=
8	0.078.1241.3	1	flywheel => (...)
9	0.047.1242.0	1	crown wheel z=128 (...) <=
9	0.065.1242.0	1	crown wheel Z = 123 => (...)
10	0.007.1260.0	1	fork 70x188x70,7 => (...) - FOR TRACTORS WITH AIR CONDITIONING
10	0.075.1244.0/10	1	pulley (...) <=
10	0.075.1244.0/20	1	pulley 70x172x55 => (...)

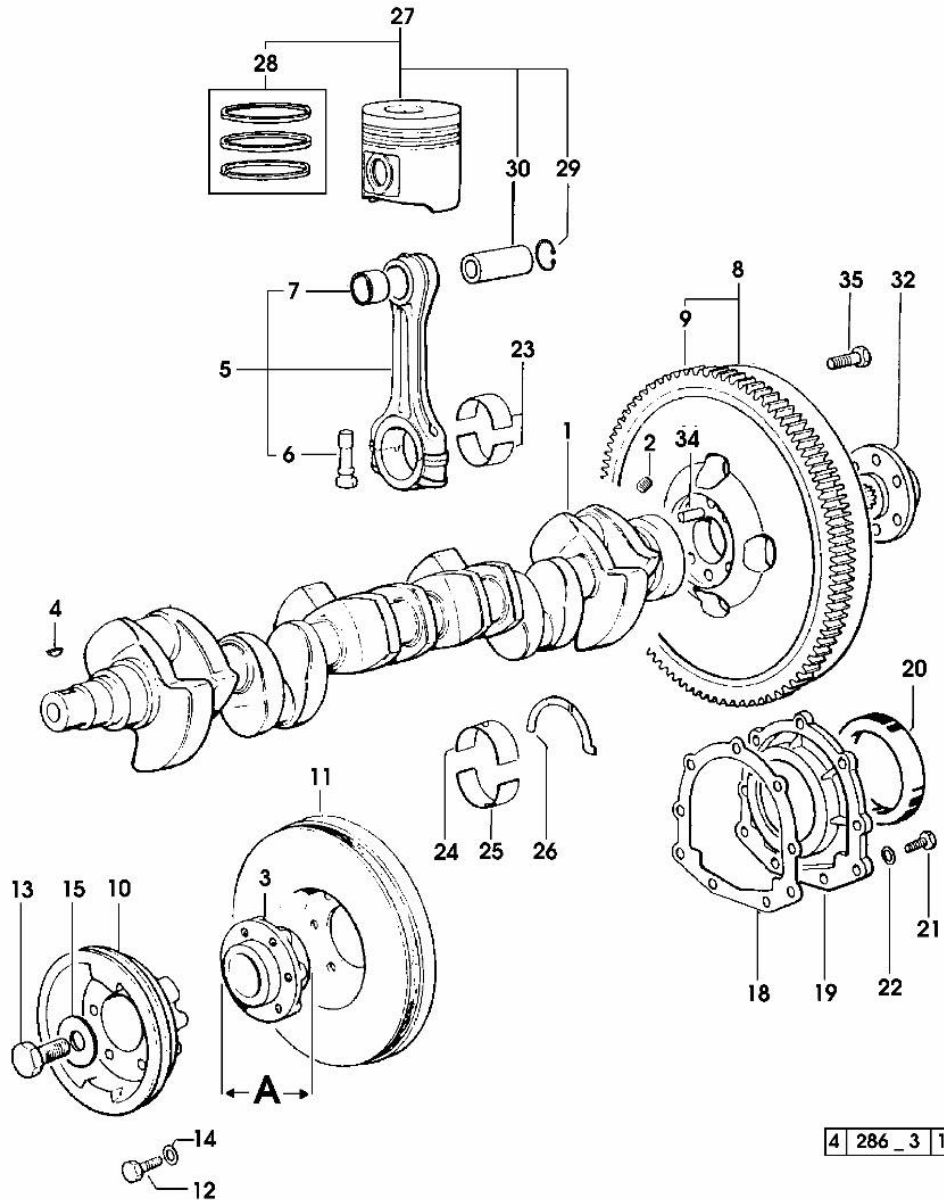

Section: ENGINE  
CRANKSHAFT

Fig.	P/n	QTY	Name
10	0.075.1252.0/10	1	pulley (...) <= - FOR TRACTORS WITH AIR CONDITIONING
11	0.007.1010.3	1	antivibration pulley - FOR VISCOUS TYPE => (...) * (...) <= - N.1 007.0896.0/20
11	0.078.1246.6	1	flywheel - FOR RUBBER TYPE (...) <=
12	2.0112.322.2	6	screw m 10 p.1.5x65
13	2.0399.144.7/10	1	screw m 20 p.1.5x51
14	2.1470.006.2	6	lock washer 10
15	2.1599.503.0	1	shoulder ring
18	0.065.1254.0/20	1	gasket
19	0.065.1253.0/20	1	cover
20	2.1529.073.0	1	special oil seal 110x130x13
21	2.0112.207.2	9	screw m 8 p 1.25 x 20
22	2.1474.009.2	9	spring washer 8
23	0.065.1225.0	12	con.rod half bushing STANDARD - A = 28.75 -> 29.00
24	0.065.1215.0	7	main half bushing STANDARD
25	0.065.1216.0	7	main half bushing
26	0.065.1218.0	4	shim STANDARD
27	0.069.0060.6	6	complete piston STANDARD - X 100HP - X 110HP
27	0.078.0060.6	1	complete piston STANDARD - X 130HP
28	0.069.0052.6	6	piston ring set - X 100HP - X 110HP
28	0.078.0052.6	6	piston ring set - X 130HP
29	2.1411.013.7	12	circlip Ø 32 - X 100HP - X 110HP
29	2.1411.014.1	12	circlip 35 - X 130HP
30	0.065.1236.0	6	piston pin - X 100HP - X 110HP
30	0.078.1236.0	6	piston pin Ø 18 / Ø 35 / L = mm 86 - X 130HP

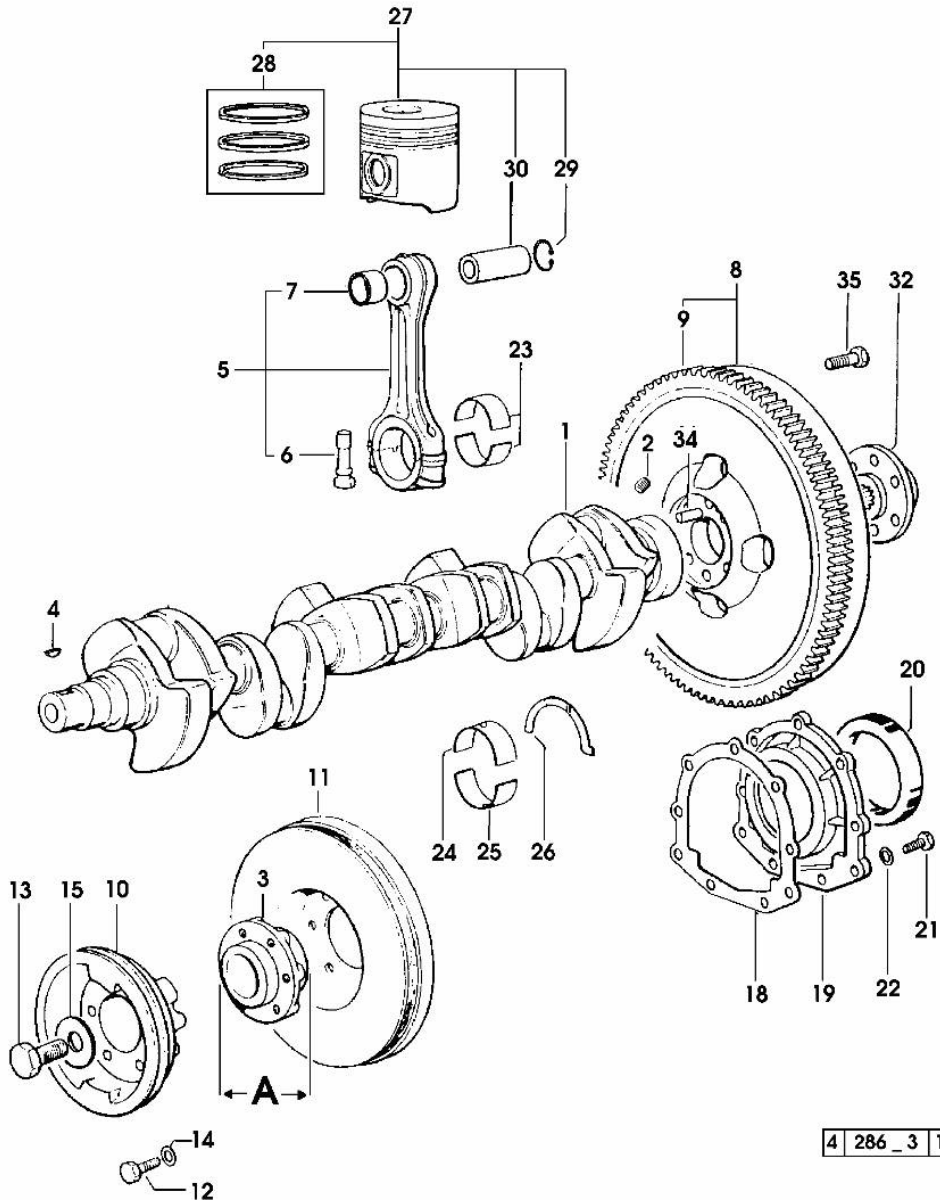

***Buy Now***



Our support email:

[ebooklibonline@outlook.com](mailto:ebooklibonline@outlook.com)