

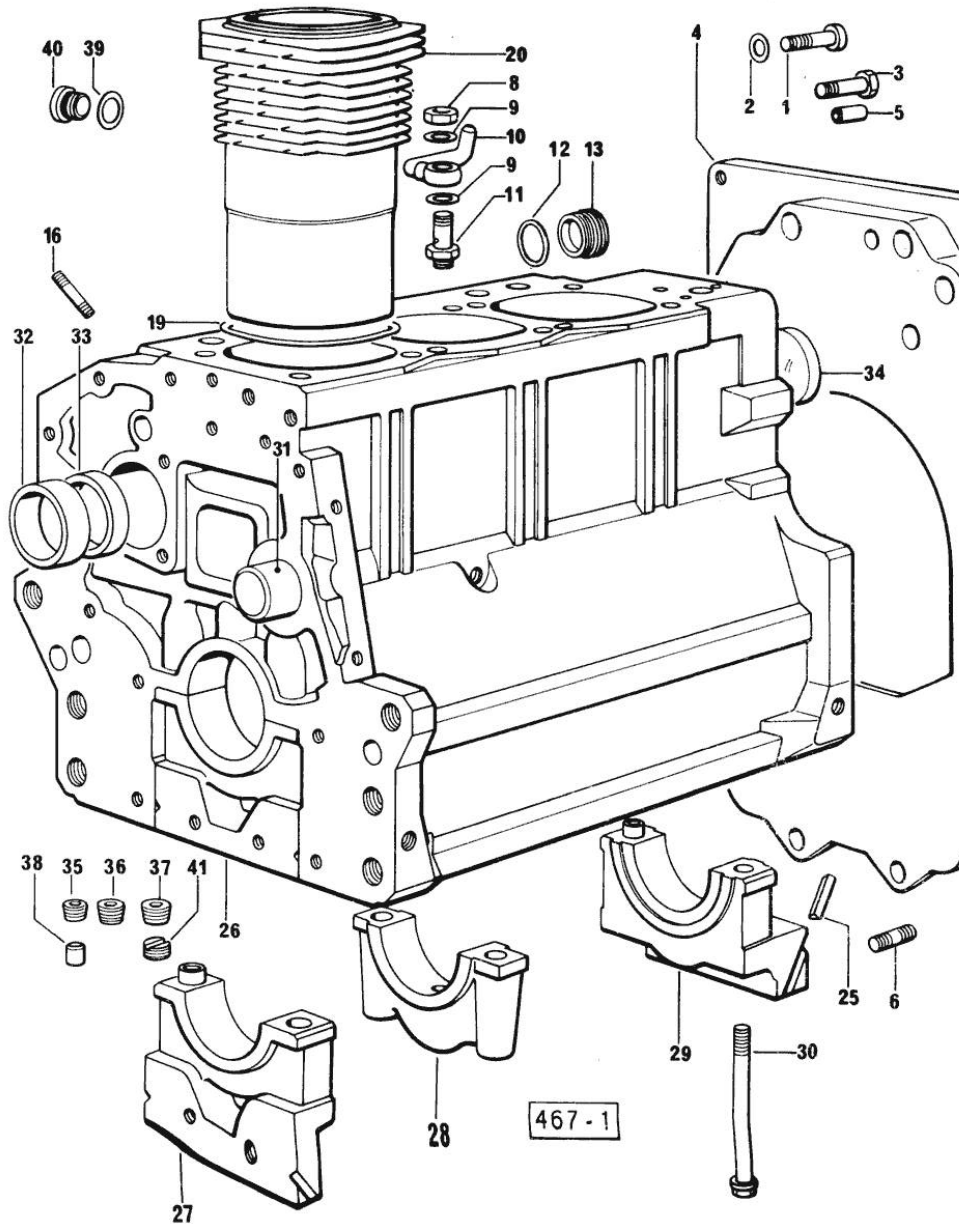
Section: ENGINE  
CRANKCASE

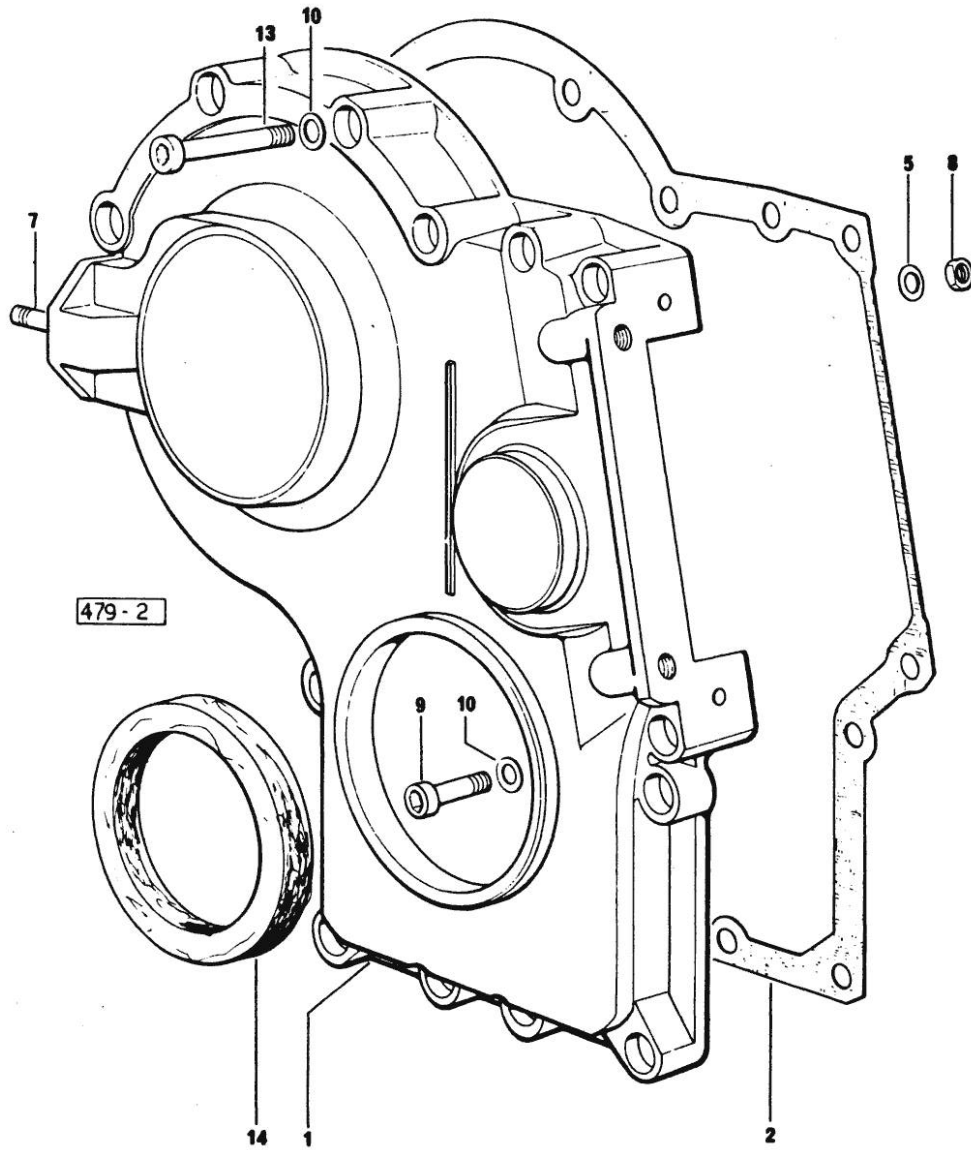
Fig.	P/n	QTY	Name
<b>Notes:</b>			
[660 V]			
0	0.085.0050.6	1	gasket set - FOR ENGINE MOUNTING
1	2.0312.516.1	2	screw m 14 p.2x50
2	2.1480.018.1	2	washer 14
3	2.0112.511.1	8	screw m 14 p.2 x 30
4	0.330.1130.0	1	extension
5	2.1651.912.0	2	cylindrical plug 12x28
6	2.0432.255.1	2	stud bolt m 12 p.1.75 - 12 p1.25x25
8	2.1099.108.2	3	special nut m 10 p.1
9	2.1560.006.0	6	gasket 10.2 x 16
10	0.086.1550.2	3	sprayer nozzle
11	0.065.1160.3/20	3	valve
12	2.1539.047.2	1	old part number
13	2.3199.405.2	1	plug m 28 p.1.5
16	2.0439.154.1	9	old part number
19	2.1519.096.0	3	oil seal
20	0.085.1120.0/10	3	engine cylinder gasket
25	0.066.1152.0	4	gasket
26	0.085.1110.4/10	1	-
27	0.065.1112.3	1	support
27	2.1699.165.0	1	bush 12.3x15x16
28	0.065.1114.0	2	old part number
29	0.065.1116.3	1	support
29	2.1699.165.0	1	bush 12.3x15x16
30	0.065.1117.0	8	screw m 12 x 100
31	0.066.1151.0/10	1	-
32	0.065.1141.0	1	special bushing 59X55X30
33	0.065.1140.0	3	special bushing 59X55X20
34	2.3179.012.0	1	plug 60
35	2.3130.001.1	11	plug 1/8" gas
36	2.3130.002.1	2	plug 1/4" gas
37	2.3130.003.1	7	plug 3/8" gas
38	2.3199.092.0	3	plug 8 x 12
39	2.1560.017.0	1	gasket 22.2 x 27
40	2.3120.002.4	1	plug m 22 x 1.5
41	2.1324.011.0	1	plug

Section: ENGINE  
TIMING CASE

Fig.	P/n	QTY	Name
------	-----	-----	------

Notes:  
[660 V]

1	0.065.1132.0/20	1	guard
2	0.065.1150.0/10	1	gasket
5	2.1470.004.2	4	lock washer 8
7	2.0432.003.7	2	stud bolt m 8 p.1.25 / p.1 x 20
8	2.1011.405.2	2	nut m 8 p.1
9	2.0312.208.1	8	screw m 8 p.1.25 x 25
10	2.1480.014.1	15	washer 8
13	2.0312.214.1	3	screw m 8 p.1.25 x 40
13	2.0312.219.2	4	screw m 8 p.1.25x65
14	2.1529.072.0	1	oil seal



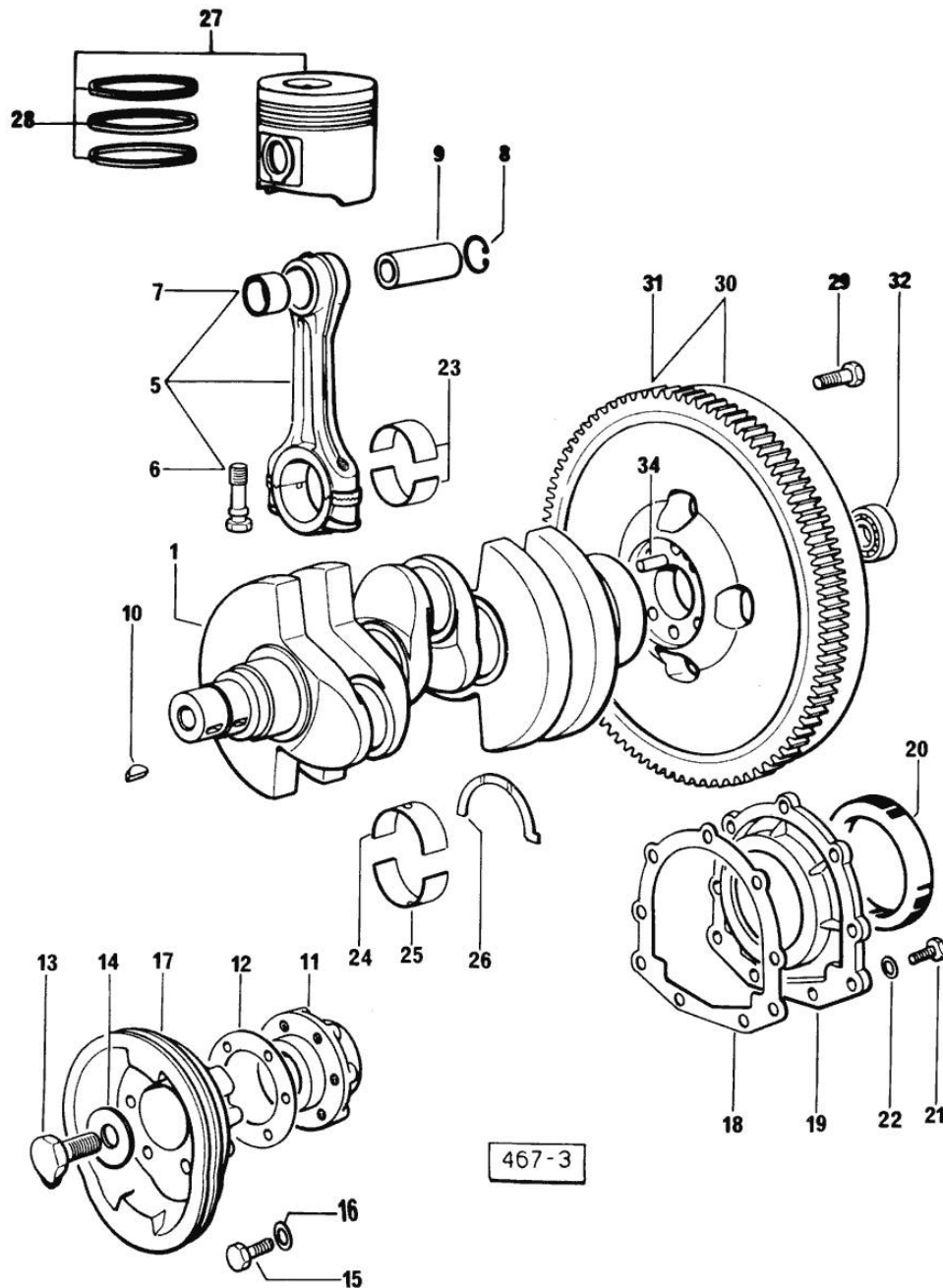

 Section: ENGINE  
**CRANKSHAFT**

Fig.	P/n	QTY	Name
<b>Notes:</b>			
[660 V]			
1	0.085.1210.3	1	crankshaft
5	0.078.1220.3/10	3	engine connecting rod - X 1000.4 W
6	2.0139.021.0	6	screw
7	2.1559.114.0/10	3	special bushing
8	2.1411.014.1	8	circlip 35
9	0.078.1236.0	3	piston pin Ø 18 / Ø 35 / L = mm 86
10	2.1720.006.0	2	key 4x6.5
11	0.065.1248.0/10	1	hub
12	2.1589.137.0	1	shoulder ring 71x110x1
13	2.0399.095.2/10	1	screw
14	2.1599.503.2	1	shoulder ring
15	2.0112.317.2	6	screw m 10 p.1.5 x 45
16	2.1470.006.2	6	lock washer 10
17	0.065.1244.0	1	pulley
18	0.065.1254.0	1	gasket
19	0.065.1253.0/10	1	cover
20	2.1529.073.0	1	special oil seal 110x130x13
21	2.0112.207.2	9	screw m 8 p 1.25 x 20
22	2.1474.009.2	9	spring washer 8
23	0.065.1225.0	6	con.rod half bushing STANDARD - A = 28.75 -> 29.00
23	0.065.1225.7	6	con.rod half bushing - mm 0.25
23	0.065.1225.8	6	con.rod half bushing - mm 0.50
24	0.065.1215.0	4	main half bushing STANDARD
24	0.065.1215.7	4	main half bushing - mm 0.25
24	0.065.1215.8	4	main half bushing - mm 0.50
25	0.065.1216.0	4	main half bushing
25	0.065.1216.7	4	main half bushing - mm 0.25
25	0.065.1216.8	4	main half bushing - mm 0.50
26	0.065.1218.0	3	shim STANDARD
26	0.065.1218.7	3	shim + mm 0.10
26	0.065.1218.8	3	shim + mm 0.15
27	0.086.0060.6	3	complete piston
28	0.086.0052.6	3	piston ring set
29	0.330.1250.0	6	screw m 12 p.1.25x98
30	0.330.1247.3	1	flywheel
31	0.069.1242.0	1	crown wheel Z = 121
32	2.2041.008.0	1	ball bearing 20x47x14
34	2.1652.915.0	1	cylindrical plug 12x35

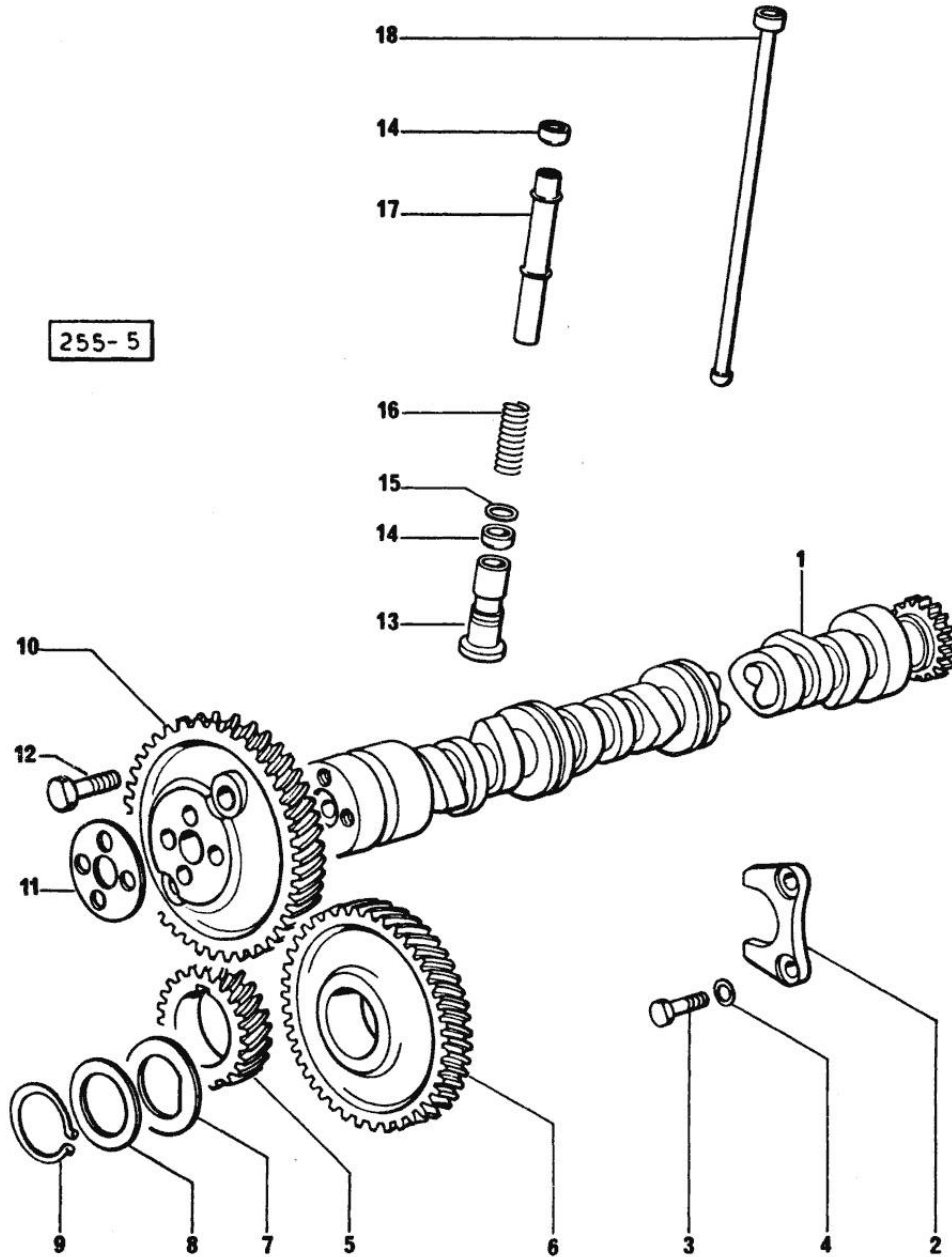
Section: ENGINE

**CAMSHAFT**

Fig.	P/n	QTY	Name
------	-----	-----	------

Notes:  
[660 V]

1	0.065.1324.0	1	gear
1	0.070.1310.3/20	1	camshaft
2	0.065.1353.0	1	small plate
3	2.0312.205.2	2	screw
4	2.1480.014.1	2	washer 8
5	065.1323.0/20	1	-
6	065.1325.3/20	1	-
6	2.1559.185.0/10	1	bushing
7	0.065.1351.0	2	shoulder ring
8	0.065.1352.0	1	shim
9	2.1410.016.1	1	circlip 40
10	0.065.1354.0/10	1	gear z=58
11	0.065.1350.0	1	small disc
12	2.0132.207.2	4	screw m 10 p.1 x 25
13	0.065.1330.0	6	tappets
14	2.1569.114.0	12	gasket
15	2.1599.437.0	6	shoulder ring
16	2.4019.300.1	6	spring
17	0.065.1332.0	6	sleeve
18	0.065.1331.2	6	rod



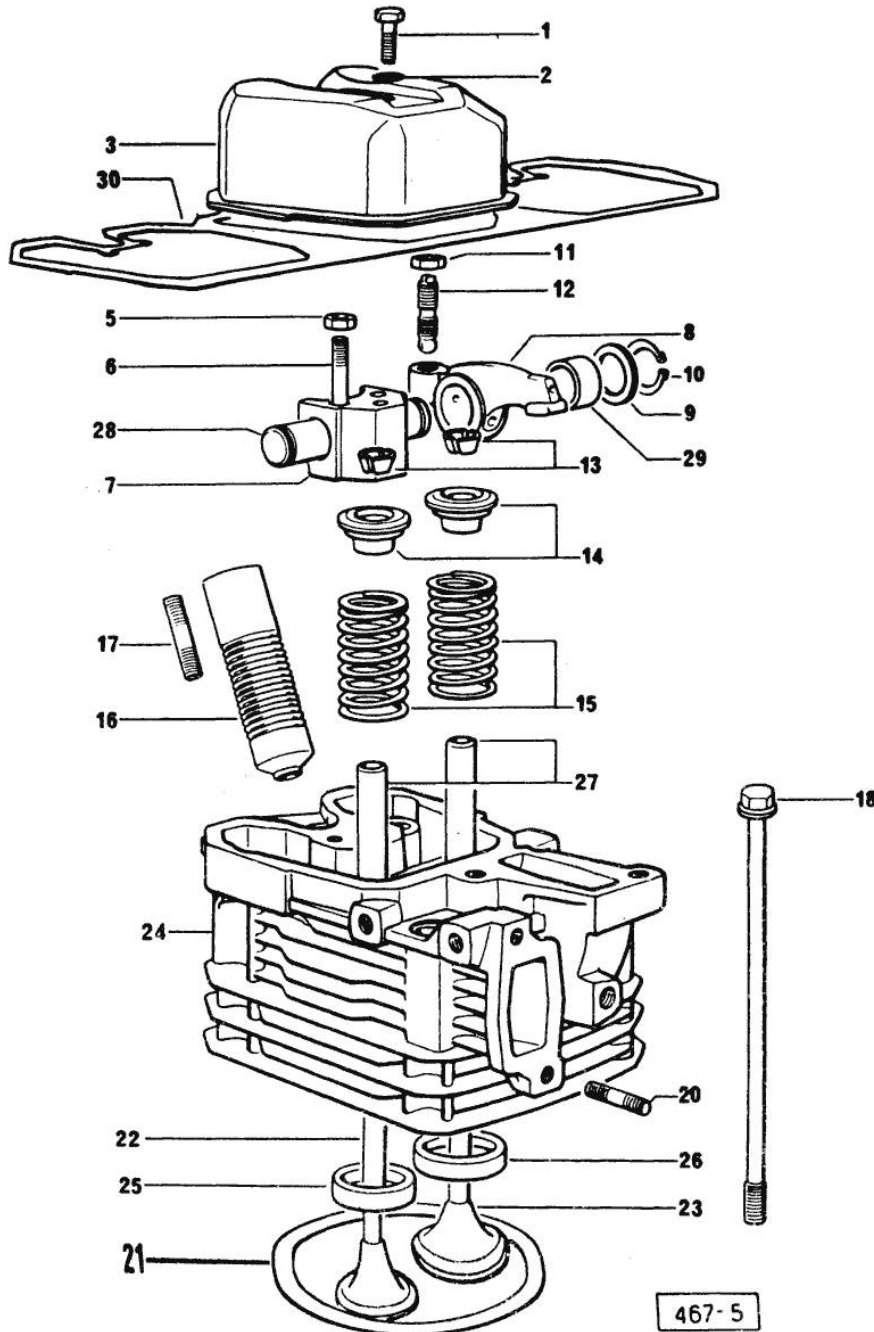
Section: ENGINE  
**CYLINDER HEAD**


Fig.	P/n	QTY	Name
<b>Notes:</b>			
[660 V]			
0	0.085.0057.6	1	gasket set - FOR GRINDING VALVES OF ONE CYLINDER
1	2.0112.211.2	3	screw m 8 p.1.25 x 30
2	2.1560.204.0	3	gasket
3	0.066.1440.0/10	3	small cap
5	2.1011.421.2	6	nut m 10 p.1.25
6	2.0432.163.1	6	stud bolt m 10 p.1.5 / p.1.25 x 45
7	0.066.1430.0	3	support
8	0.066.1432.0	6	rocker arm
9	2.1599.432.0	6	shoulder ring
10	2.1410.055.1	6	circlip 19
11	2.1011.405.2	6	nut m 8 p.1
12	0.021.1434.0	6	screw
13	0.074.1423.0	6	conical valve cotter
14	0.066.1425.0	6	cup
15	2.4019.287.0	6	spring
16	0.065.1413.0/10	3	bush L = mm 97.1
17	2.0432.161.7	3	stud bolt m 10 p.1.5 / p.1.25 x 40
18	0.065.1443.0/20	12	screw
20	2.0432.007.1	6	stud bolt m 8 p.1.25 / p.1 x 30
21	0.085.1450.0	3	head gasket mm 0.5 -A-
21	0.085.1451.0	4	head gasket mm 0.7 -B-
21	0.085.1452.0	4	head gasket mm 1.0 -C-
21	0.085.1453.0	1	head gasket mm 0.8 -D-
22	0.066.1421.0	3	exhaust valve
23	0.078.1420.0	3	inlet valve
24	0.081.1410.3/10	3	engine head
25	0.066.1427.0	3	valve seat
26	0.078.1426.0	3	valve seat
27	0.066.1416.0	6	valve guide
28	0.066.1431.0	3	pin
29	2.1559.021.0/40	6	bushing 15x19x22
30	0.069.1450.0/10	1	gasket

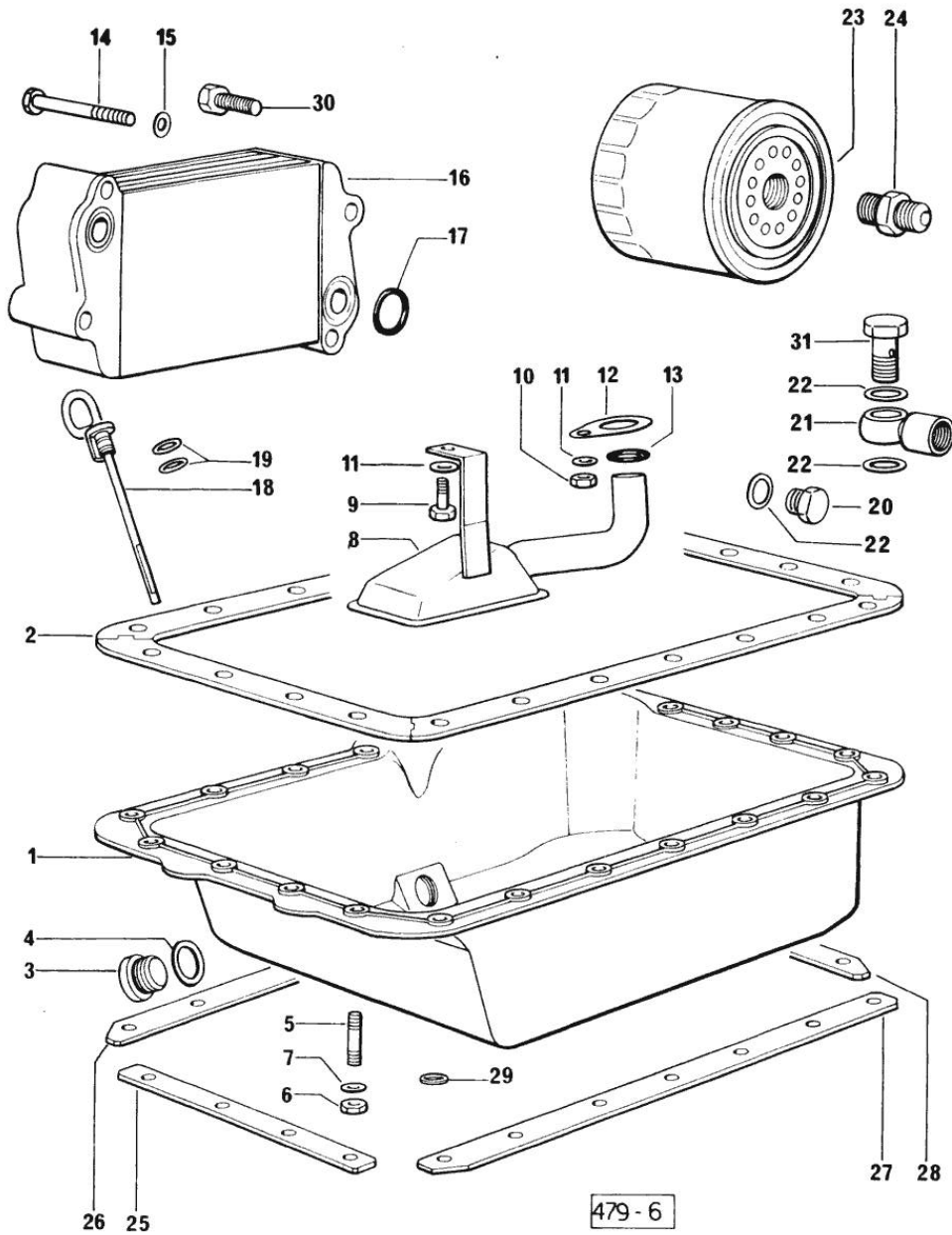
Section: ENGINE  
LUBRICATION

Fig.	P/n	QTY	Name
<b>Notes:</b>			
[660 V]			
1	0.070.1510.2/20	1	oil sump
2	0.070.1551.0	1	gasket
3	2.3199.001.2	1	plug 1/2" gas
4	2.1560.054.0	1	gasket 21 x 26
5	2.0432.003.1	22	stud bolt m 8 p.1.25 / p.1 x 20
6	2.1121.105.2	22	nut m 8 x 1
7	2.1470.004.2	22	lock washer 8
8	0.070.1531.3	1	tube
9	2.0112.205.2	1	screw m 8 p.1.25 x 16
10	2.1011.105.2	1	nut m 8 p.1.25
11	2.1470.004.2	2	lock washer 8
12	0.065.1538.0	1	flange
13	2.1539.040.0	1	special oil seal 21.82 x 3.53
14	2.0312.216.1	2	screw
15	2.1310.004.2	4	flat washer 8.4x17
16	0.085.1540.3	1	oil cooler
17	2.1539.048.0	2	special oil seal 20.35x1.78
18	0.085.1513.2	1	dipstick mm 78
19	2.1539.065.0	2	special oil seal 8.73 x 1.78
20	2.3110.402.1	1	plug m 12 p.1.5x10
21	2.3249.014.2	1	pipe fitting m 12 p.1.5
22	2.1560.008.0	3	gasket 12.2 x 18
23	0.044.1554.0	1	grease cartridge
24	2.3339.307.1/20	1	pipe fitting
25	0.070.1554.0	1	small plate
26	0.070.1552.0	1	small plate
27	0.070.1553.0	1	small plate
28	0.070.1555.0	1	small plate
29	2.1599.459.0	3	small plate
30	2.0399.125.2	2	screw
31	2.3339.448.2	1	pipe union m 12 p.1.75

Section: ENGINE  
LUBRICATION

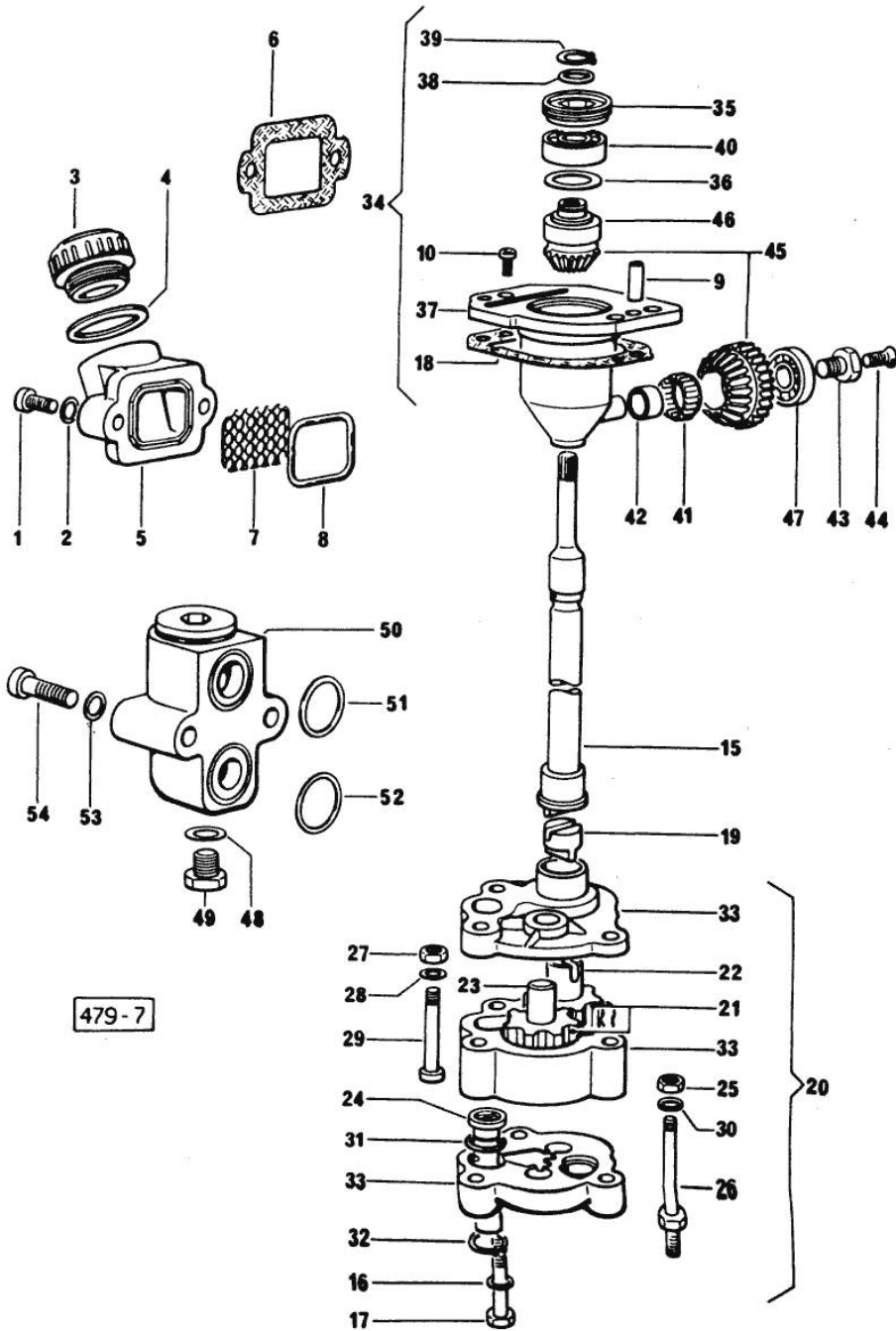


Fig.	P/n	QTY	Name
------	-----	-----	------

Notes:  
[660 V]

1	2.0312.205.2	2	screw
2	2.1480.014.1	2	washer 8
3	0.041.1135.4	1	plug 1" gas
4	2.1569.072.0	1	gasket 32 x 39.5 x 2
5	0.065.1565.0/10	1	pipe union
6	0.065.1566.0	1	gasket
7	0.065.1567.0/10	1	filter
8	2.1539.042.0	1	special oil seal 47.35x1.78
9	2.1652.711.0	2	cylindrical plug 8x25
10	2.0169.005.2	2	screw m 6 p.1 x 12
15	0.065.1569.0	1	shaft
16	2.1470.006.2	2	lock washer 10
17	2.0112.323.2	2	screw m 10 p.1.5x70
18	0.065.1560.0/10	2	gasket
19	0.065.1562.0	1	joint
20	9.06699.42.2	1	old part number
21	0.066.1521.0/20	2	gear
22	0.066.1528.0/10	1	pin
23	0.066.1529.0/10	1	small shaft
24	0.065.1552.3/40	1	valve
25	2.1011.105.2	1	nut m 8 p.1.25
26	2.0399.119.2	1	screw
27	2.1011.103.2	1	nut m 6 p.1
28	2.1480.012.1	1	washer 6, d128
29	2.0312.115.1	1	screw m 6 p.1x45
30	2.1480.014.1	1	washer 8
31	2.1539.041.0	1	special oil seal
32	2.1410.004.1	1	circlip 16
33	0.000.0000.1	1	cannot be supplied
34	9.07599.43.3	1	old part number
35	2.1219.025.2/10	1	ring nut m 36 p.1.5
36	2.1589.148.0	1	shoulder ring 28.2 x 31.8 x 0.5
36	2.1589.150.0	1	shoulder ring 28.2 x 31.8 x 0.1
36	2.1589.151.0	1	shoulder ring 28.2 x 31.8 x 0.15
37	0.075.1551.3/20	1	support
38	2.1589.146.0	1	shoulder ring 15.2 x 19 x 0.15
38	2.1589.147.0	1	shoulder ring 15.2 x 19 x 0.10
38	2.1589.153.0	1	shoulder ring 15.2 x 19 x 1.00
39	2.1410.057.1	1	circlip 15
40	2.2020.001.0	1	ball bearing 15 x 32 x 8.00
41	2.2725.016.0	1	roller cage 15 x 21 x 12

**Buy Now**



Our support email:

[ebooklibonline@outlook.com](mailto:ebooklibonline@outlook.com)