

Section: ENGINE
CRANKCASE

Fig.	P/n	QTY	Name
------	-----	-----	------

Notes:
[674-70 GRAND PRIX]

1	0.089.0050.6	1	gasket set - X 674-70 - 774-80 - FOR ENGINE MOUNTING
1	0.090.0050.6	1	gasket set - X 874-90T - FOR ENGINE MOUNTING
2	2.1519.096.0/20	12	special oil seal 107.67x1.78 25065 <= X 674-70 24928 <= X 774-80 6740 <= X 874-90
2	2.1539.193.0	8	special oil seal 107.62x2.62 => 25066 X 674-70 => 24929 X 774-80 => 6741 X 874-90
3	2.1559.188.2	4	bush 11.4 x 14 x16
4	2.0432.003.7	12	stud bolt m 8 p.1.25 / p.1 x 20
5	0.009.7500.0/10	4	engine cylinder = A 17700 <= X 674-70 - 774-80 5428 <= X 874-90
5	0.011.0183.0/20	4	engine cylinder => 25066 X 674-70 => 24929 X 774-80 => 6741 X 874-90
5	0.011.0582.0	4	engine cylinder = B => 17701 - 25065 <= X 674-70 => 17701 - 24928 <= X 774-80 => 5429 - 6740 <= X 874-90
7	2.1549.154.2	4	bush 4.8x5.8x16
8	0.066.1130.0/20	1	flange
14	2.3199.405.2	1	plug m 28 p.1.5
15	2.1539.047.0	1	special oil seal 26.7x1.78
16	2.1099.108.2	4	special nut m 10 p.1
17	2.1560.006.0	8	gasket 10.2 x 16
18	0.086.1550.2	4	sprayer nozzle
19	0.065.1160.3/20	4	valve
20	2.3199.292.0	1	plug 1/4" gas
21	2.1560.010.0	1	gasket 14.2 x 20
24	0.066.1152.0/10	4	gasket
25	0.082.1110.6/20	1	crankcase

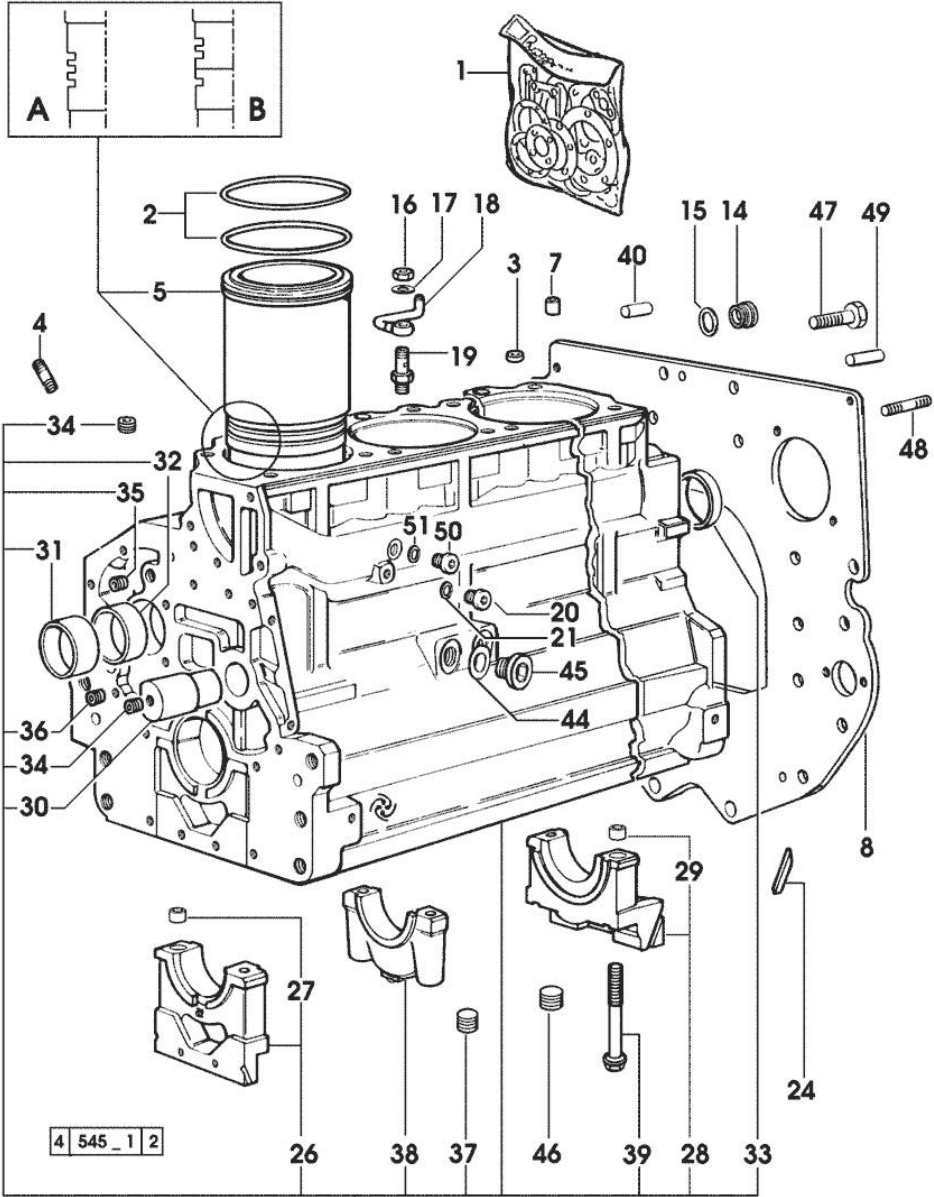

Section: ENGINE
CRANKCASE

Fig.	P/n	QTY	Name
			* 25065 <= X 674-70
			* 24928 <= X 774-80
			* 6740 <= X 874-90
			- N.4 011.0183.0/10 - N.8 2.1539.193.0
26	0.065.1112.7	1	support
27	2.1699.165.0	1	bush 12.3x15x16
28	0.065.1116.3	1	support
29	2.1699.165.0	1	bush 12.3x15x16
30	0.066.1151.0	1	pin
31	0.065.1141.0	1	special bushing 59X55X30
32	0.065.1140.0	4	special bushing 59X55X20
33	2.3179.012.0	1	plug 60
34	2.3130.001.1	11	plug 1/8" gas
35	2.3130.002.1	2	plug 1/4" gas
36	2.3130.003.1	5	plug 3/8" gas
37	2.1324.011.0	1	plug
38	0.065.1114.0/10	3	support
39	0.065.1117.0	10	screw m 12 x 100
40	2.1651.912.0	2	cylindrical plug 12x28
44	2.1560.017.0	1	gasket 22.2 x 27 - X 674-70 - 774-80
45	2.3120.002.4	1	plug m 22 x 1.5 - X 674-70 - 774-80
46	2.3130.003.1	2	plug 3/8" gas
47	2.0112.511.2	8	screw m 14 p.2 x 30
48	2.0432.255.7	2	stud bolt m 12 p.1.75-1.25x25
49	2.1651.917.0	1	cylindrical plug 12x40
50	2.3120.101.0	1	plug m 18 p.1.5 => 25066 X 674-70 => 24929 X 774-80 => 6741 X 874-90
51	2.1560.014.0	1	washer 18.2 x 24

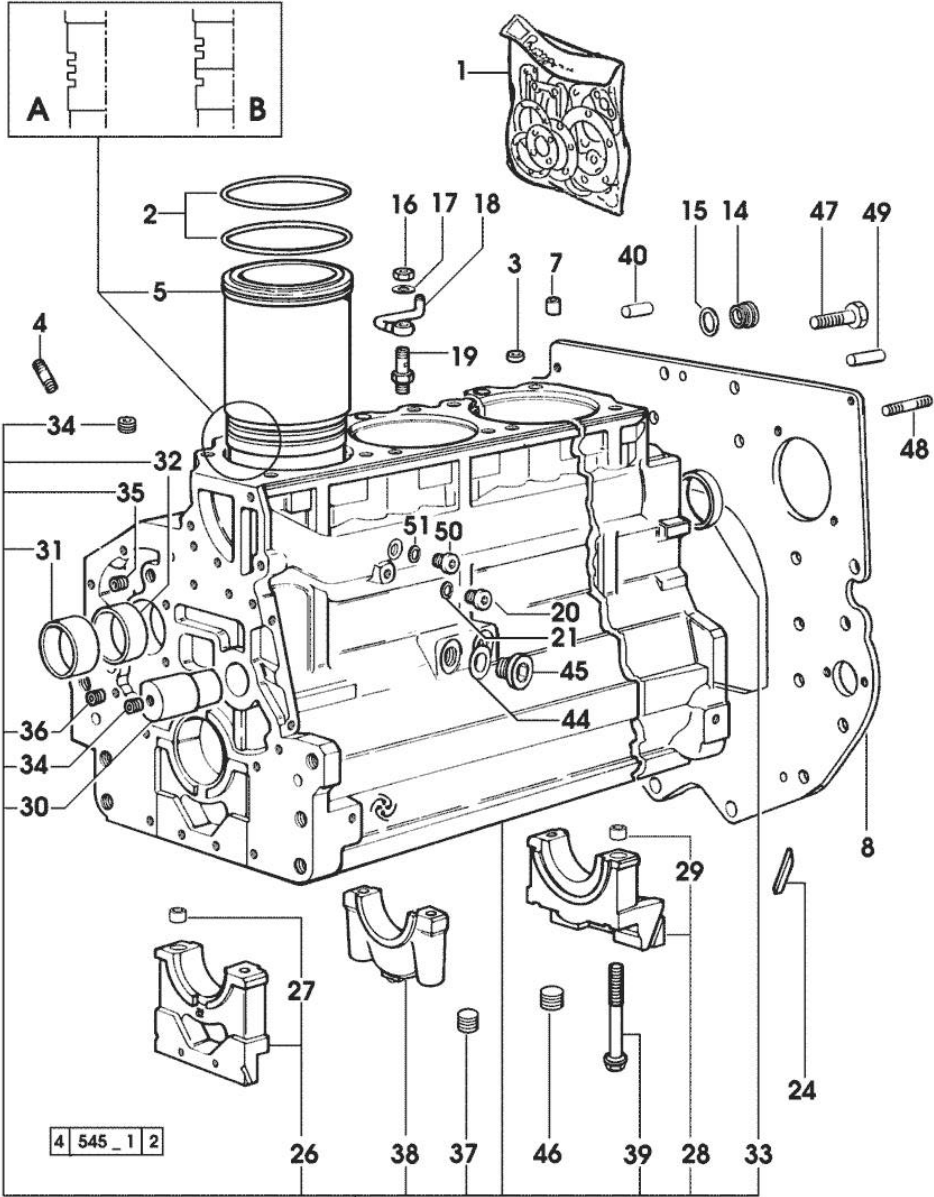

Section: ENGINE
TIMING CASE

Fig.	P/n	QTY	Name
------	-----	-----	------

Notes:
[674-70 GRAND PRIX]

1	0.007.1262.3/50	1	guard
2	0.007.1271.0/10	1	small column m 8 p.1.25 / L = mm 60
3	0.007.1272.0/10	2	small column m 8 p.1.25 / L = mm 50
5	2.1310.004.2	3	flat washer 8.4x17
7	2.0112.205.2	3	screw m 8 p.1.25 x 16

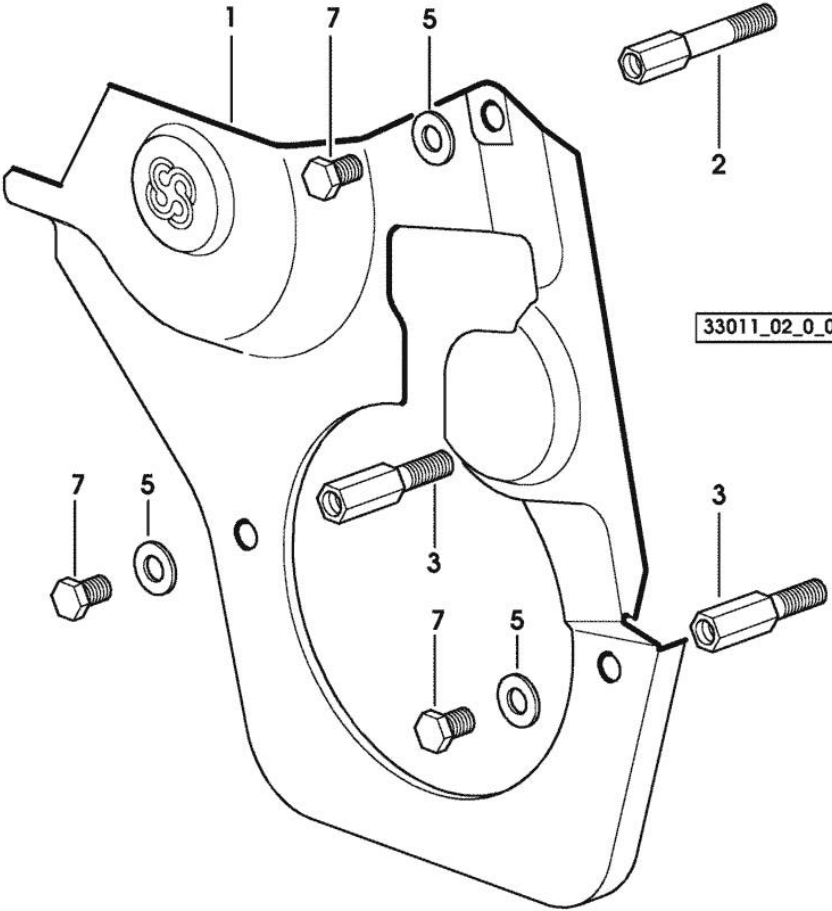

Section: ENGINE

TIMING CASE

Fig.	P/n	QTY	Name
------	-----	-----	------

Notes:

[674-70 GRAND PRIX]

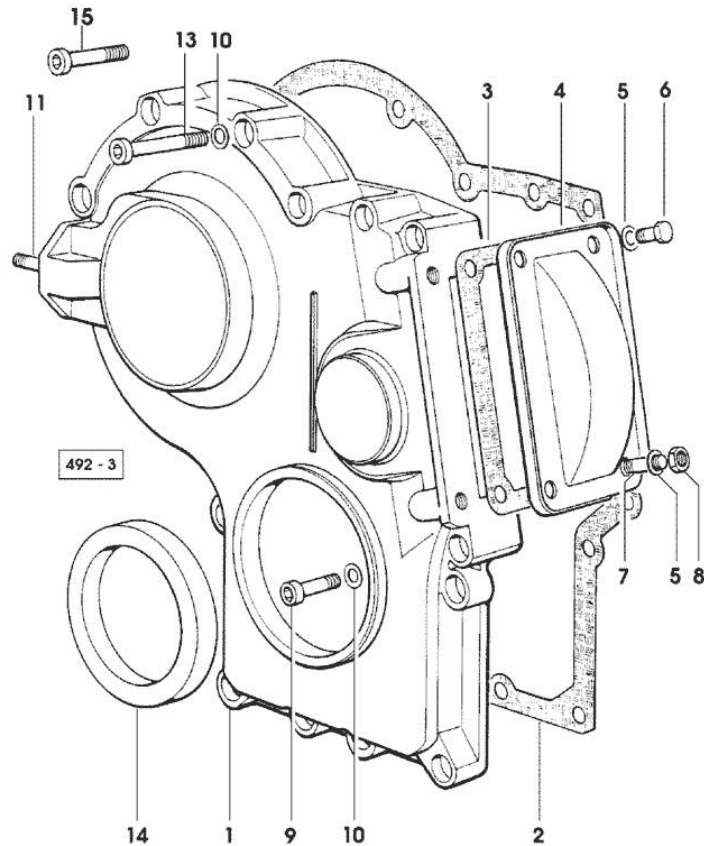

1	0.065.1132.0/60	1	guard
2	0.065.1150.0/30	1	gasket
3	0.065.1152.0	1	gasket
4	0.065.1151.0	1	cover
5	2.1470.004.2	4	lock washer 8
6	2.0112.205.2	2	screw m 8 p.1.25 x 16
7	2.0432.003.7	2	stud bolt m 8 p.1.25 / p.1 x 20
8	2.1011.405.2	2	nut m 8 p.1
9	2.0312.208.2	8	screw m 8 p.1.25 x 25
10	2.1480.014.1	15	washer 8
11	2.0432.003.7	2	stud bolt m 8 p.1.25 / p.1 x 20
13	2.0312.214.2	3	screw m 8 p.1.25 x 40
14	2.1529.141.0	1	special oil seal
15	2.0312.214.2	4	screw m 8 p.1.25 x 40

Section: ENGINE

CRANKSHAFT

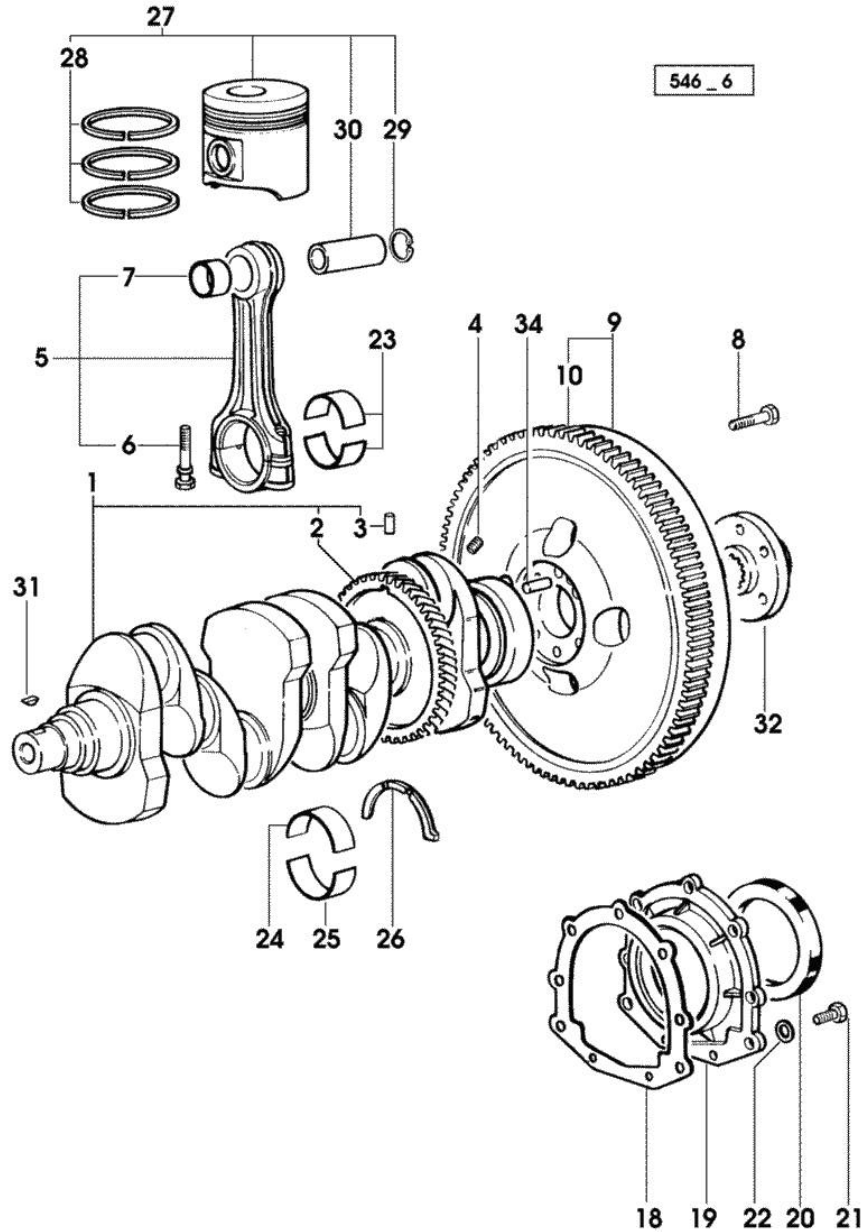

Fig.	P/n	QTY	Name
Notes:			
[674-70 GRAND PRIX]			
1	0.086.1210.3/30	1	crankshaft * 14871 <= - N.1 - 007.1711.0/10 - N.4 - 2.3130.001.1
2	0.065.1211.0/10	1	crown wheel
3	2.1630.608.0	1	pin 6x16
4	2.3130.001.1	4	plug 1/8" gas
5	0.078.1220.3/30	4	engine connecting rod
6	2.0399.213.0	8	screw m 12 p.1.25x61.5
7	2.1559.114.0/10	4	special bushing
8	2.0139.022.2	6	screw m 12 p.1.25x55
9	0.065.1247.3/30	1	flywheel
9	0.076.1247.3/20	1	flywheel 21102 <= -> 21103
10	0.065.1242.0	1	crown wheel Z = 123
18	0.065.1254.0/20	1	gasket
19	0.007.1711.0/10	1	cover
19	0.065.1253.0/20	1	cover => 14872 14871 <=
20	2.1529.073.0	1	special oil seal 110x130x13
21	2.0112.207.2	9	screw m 8 p 1.25 x 20
22	2.1475.002.2	9	conical washer 8
23	0.065.1225.0	8	con.rod half bushing STANDARD - A = 28.75 -> 29.00
23	0.065.1225.7		con.rod half bushing - mm 0.25
23	0.065.1225.8		con.rod half bushing - mm 0.50
24	0.065.1215.0	5	main half bushing STANDARD
24	0.065.1215.7		main half bushing - mm 0.25
24	0.065.1215.8		main half bushing - mm 0.50
25	0.065.1216.0	5	main half bushing
25	0.065.1216.7		main half bushing - mm 0.25
25	0.065.1216.8		main half bushing - mm 0.50
26	0.065.1218.0	4	shim STANDARD
26	0.065.1218.7		shim + mm 0.10
26	0.065.1218.8		shim + mm 0.15
27	0.086.0060.6/30	4	complete piston
27	0.379.0060.6	4	complete piston - EXPORT U.S.A.
28	0.086.0052.6/10	4	piston ring set
29	2.1411.014.1	8	circlip 35
30	0.078.1236.0	4	piston pin Ø 18 / Ø 35 / L = mm 86

CRANKSHAFT

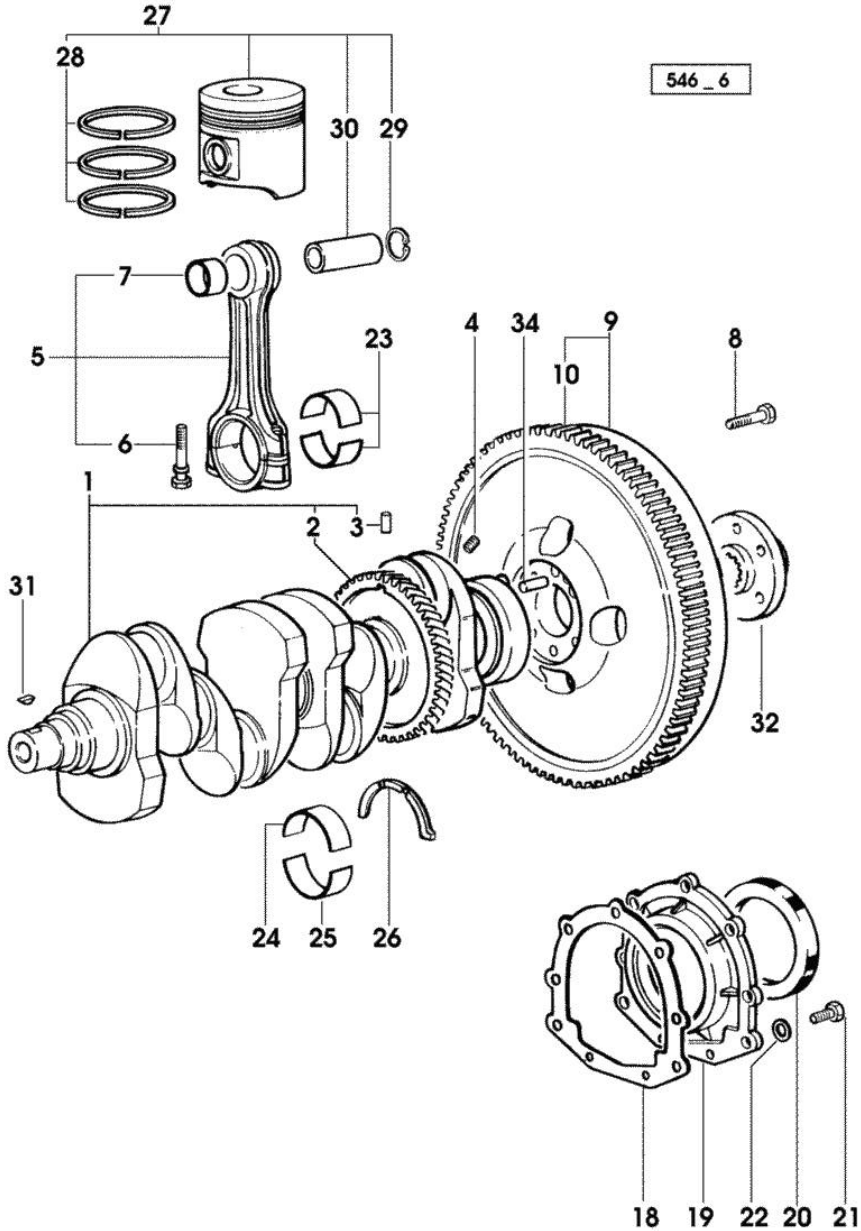

Fig.	P/n	QTY	Name
31	2.1720.006.0	3	key 4x6.5
32	0.255.2525.0/10	1	flange
34	2.1652.915.0	1	cylindrical plug 12x35

Section: ENGINE

ENGINE SHAFT - PULLEYS

Fig.	P/n	QTY	Name
------	-----	-----	------

Notes:

[674-70 GRAND PRIX]

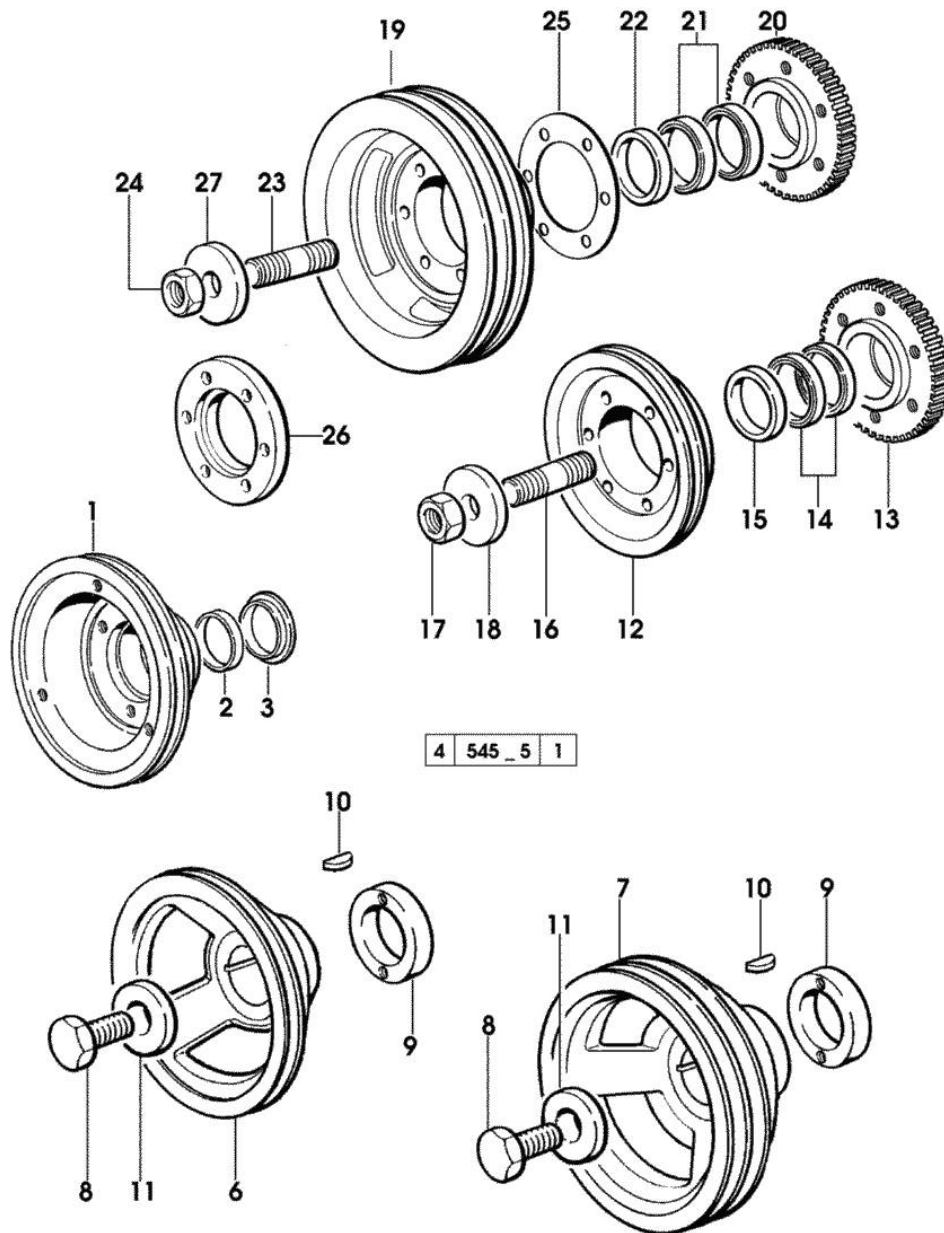

1	0.089.1251.0/10	1	pulley (...)-<
1	0.089.1252.0/10	1	pulley (...)-< - FOR TRACTORS WITH AIR CONDITIONING
2	0.085.1254.0	1	ring
3	0.065.1256.0	1	ring 45x52
6	0.007.1457.0/20	1	pulley
7	0.007.1458.0/30	1	pulley - FOR TRACTORS WITH AIR CONDITIONING
8	2.0399.144.7/10	1	screw m 20 p.1.5x51 * (...)-< - N.1 - 2.1599.524.7
9	0.085.1248.0/10	1	hub
10	2.1720.006.0	1	key 4x6.5
11	2.1599.524.7	1	washer 21x60x12 * (...)-< - N.1 - 2.0399.144.7
12	0.082.1244.0/10	1	pulley -> (...)
13	0.011.3515.0/10	1	hub Z = 48
14	0.065.1256.0	2	ring 45x52
15	2.1579.865.0	4	spacer 45.2x51.8x10
16	2.0439.195.7	1	stud bolt m 20 p.1.5x80
17	2.1019.094.7	1	nut m 20 p.1.5
18	2.1599.524.7	1	washer 21x60x12
19	0.082.1250.0/10	1	pulley -> (...) - FOR TRACTORS WITH AIR CONDITIONING
20	0.011.3515.0/10	1	hub Z = 48
21	0.065.1256.0	2	ring 45x52
22	2.1579.865.0	1	spacer 45.2x51.8x10
23	2.0439.195.7	1	stud bolt m 20 p.1.5x80
24	2.1019.094.7	1	nut m 20 p.1.5
25	2.1589.137.0	3	shoulder ring 71x110x1
26	0.089.1253.0/10	1	spacer
27	2.1599.524.7	1	washer 21x60x12

Buy Now



Our support email:

ebooklibonline@outlook.com