

Section: ENGINE
CRANKCASE

Fig.	P/n	QTY	Name
Notes:			
[774-80]			
0	0.066.0050.6	1	gasket set
FOR INSTALLATION OF 916.4 W ENGINE			
0	0.089.0050.6	1	gasket set
FOR INSTALLATION OF 1000.4 W ENGINE			
1	0.066.1120.0/10	4	engine cylinder
X 916.4 W			
1	0.088.1120.0/10	4	engine cylinder
X 1000.4 W			
2	2.1519.096.0/10	8	oil seal 107.67x1.78
3	2.1559.188.0/10	4	bush
4	2.0439.154.0	12	old part number
7	2.1631.205.0	4	roll pin
8	0.066.1130.0/20	1	flange
14	2.3199.405.2	1	plug m 28 p.1.5
15	2.1539.047.0	1	special oil seal 26.7x1.78
16	2.1099.108.2	4	special nut m 10 p.1
17	2.1560.006.0	8	gasket 10.2 x 16
18	0.086.1550.2	4	sprayer nozzle
19	0.065.1160.3/20	4	valve
20	0.049.1152.0	1	cock
21	2.1560.009.0	1	gasket 14.2x18
24	0.066.1152.0/10	4	gasket
25	9.06699.43.4	1	crankcase
X 916.4 W			
25	9.08299.42.2	1	crankcase - X 916.4 W
X 1000.4 W			
26	0.065.1112.3	1	support
26	2.1699.165.0	1	bush 12.3x15x16
27	0.065.1114.0	3	old part number
28	0.065.1116.3	1	support
28	2.1699.165.0	1	bush 12.3x15x16
29	0.065.1117.0	10	screw m 12 x 100
30	0.066.1151.0	1	pin
31	0.065.1141.0	1	special bushing 59X55X30
32	0.065.1140.0	4	special bushing 59X55X20
33	2.3179.012.0	1	plug 60
34	2.3130.001.1	11	plug 1/8" gas
35	2.3130.002.1	2	plug 1/4" gas
36	2.3130.003.1	2	plug 3/8" gas
37	2.1324.011.0	1	plug
X 1000.4 W			

Section: ENGINE
CRANKCASE

296-1

Fig.	P/n	QTY	Name
38	2.0112.511.2	8	screw m 14 p.2 x 30
39	2.0432.255.2	2	stud bolt m 12 p.1.75-1.25x25
40	2.1651.912.0	2	cylindrical plug 12x28
41	2.1651.917.0	1	cylindrical plug 12x40
42	0.065.1156.0	2	gasket (...)<=
43	0.065.1143.3/10	1	body (...)<=
44	2.1470.004.2	2	lock washer 8
45	2.0312.219.2	2	screw m 8 p.1.25x65
46	2.6859.074.2/10	1	clamp (...)<=
47	2.6859.072.2	1	clamp
48	0.065.1165.2	1	sediment bowl (...)<=
49	2.6859.073.2	2	clamp
50	0.065.1166.0	1	sleeve (...)<=
51	0.065.1155.0/10	1	tube (...)<=
52	0.065.1157.0	1	bracket
53	2.1011.103.2	1	nut m 6 p.1
54	2.1470.002.2	1	lock washer 6
55	2.0112.004.2	1	screw m 6 p.1 x 14

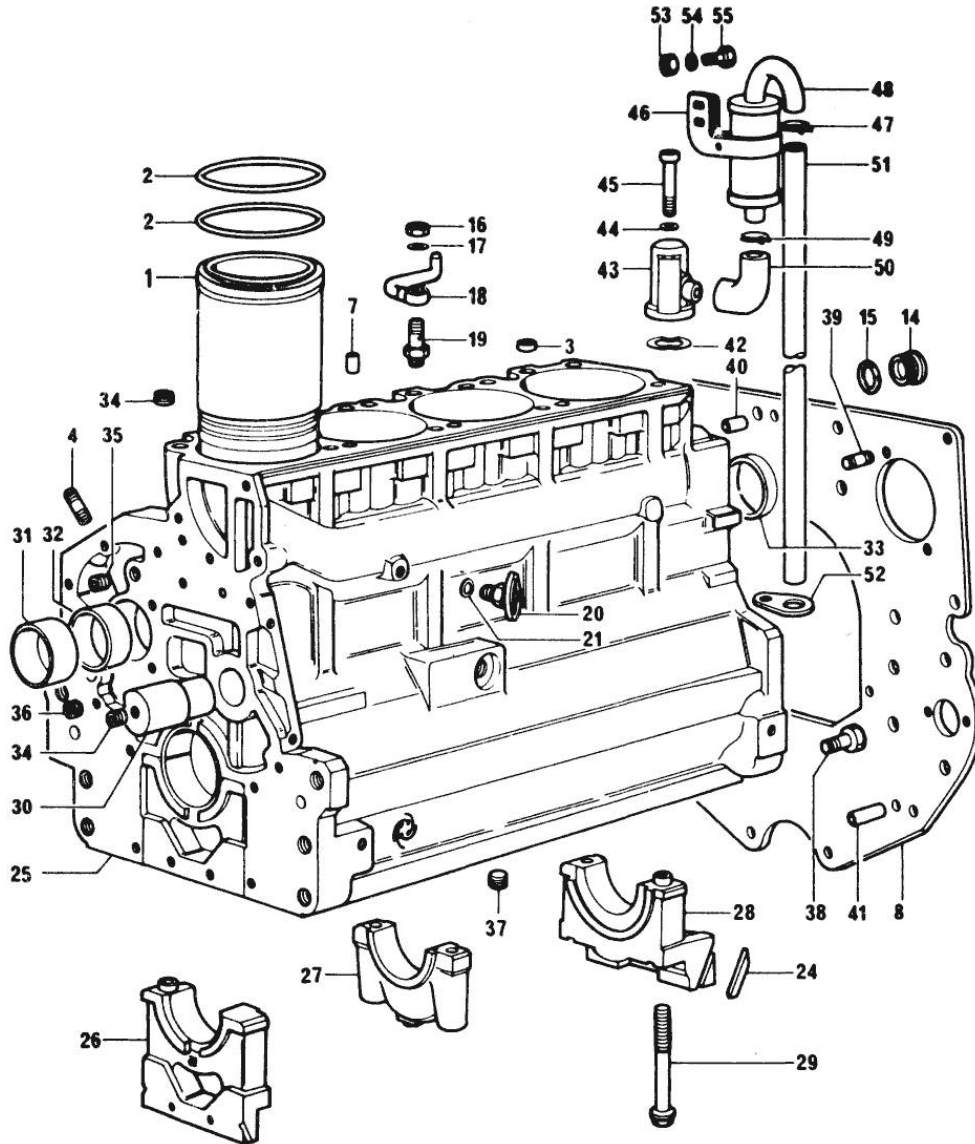
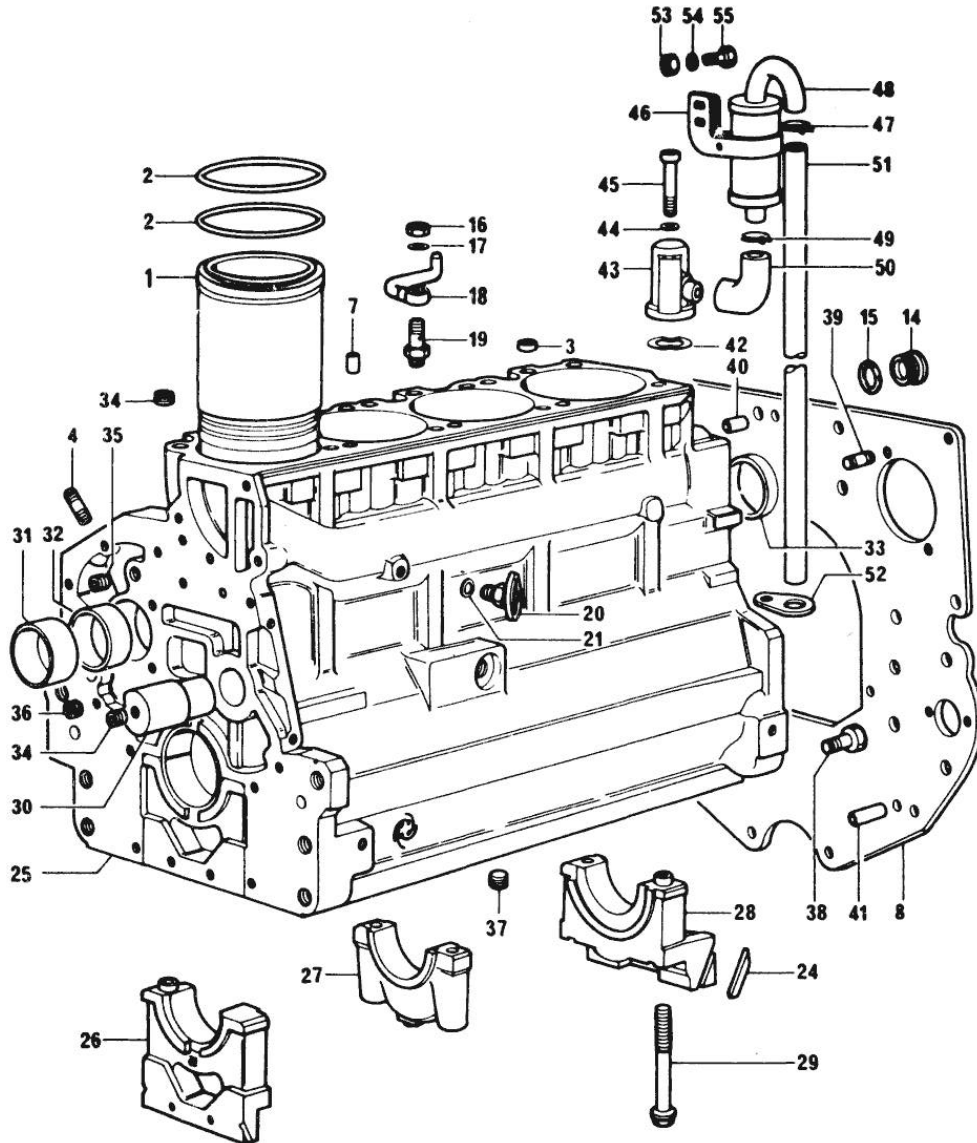
Section: ENGINE

TIMING CASE

Fig.	P/n	QTY	Name
------	-----	-----	------

Notes:
[774-80]

1	0.065.1132.0/20	1	guard
2	0.065.1150.0/10	1	gasket
3	0.065.1152.0	1	gasket
4	0.065.1151.0	1	cover
5	2.1470.004.2	4	lock washer 8
6	2.0112.205.2	2	screw m 8 p.1.25 x 16
7	2.0432.001.1	2	stud bolt m 14 p.2-1.5x35
8	2.1011.405.2	2	nut m 8 p.1
9	2.0312.208.1	8	screw m 8 p.1.25 x 25
10	2.1480.014.1	15	washer 8
11	2.0432.003.7	2	stud bolt m 8 p.1.25 / p.1 x 20
13	2.0312.214.2	7	screw m 8 p.1.25 x 40
14	2.1529.072.0	1	oil seal

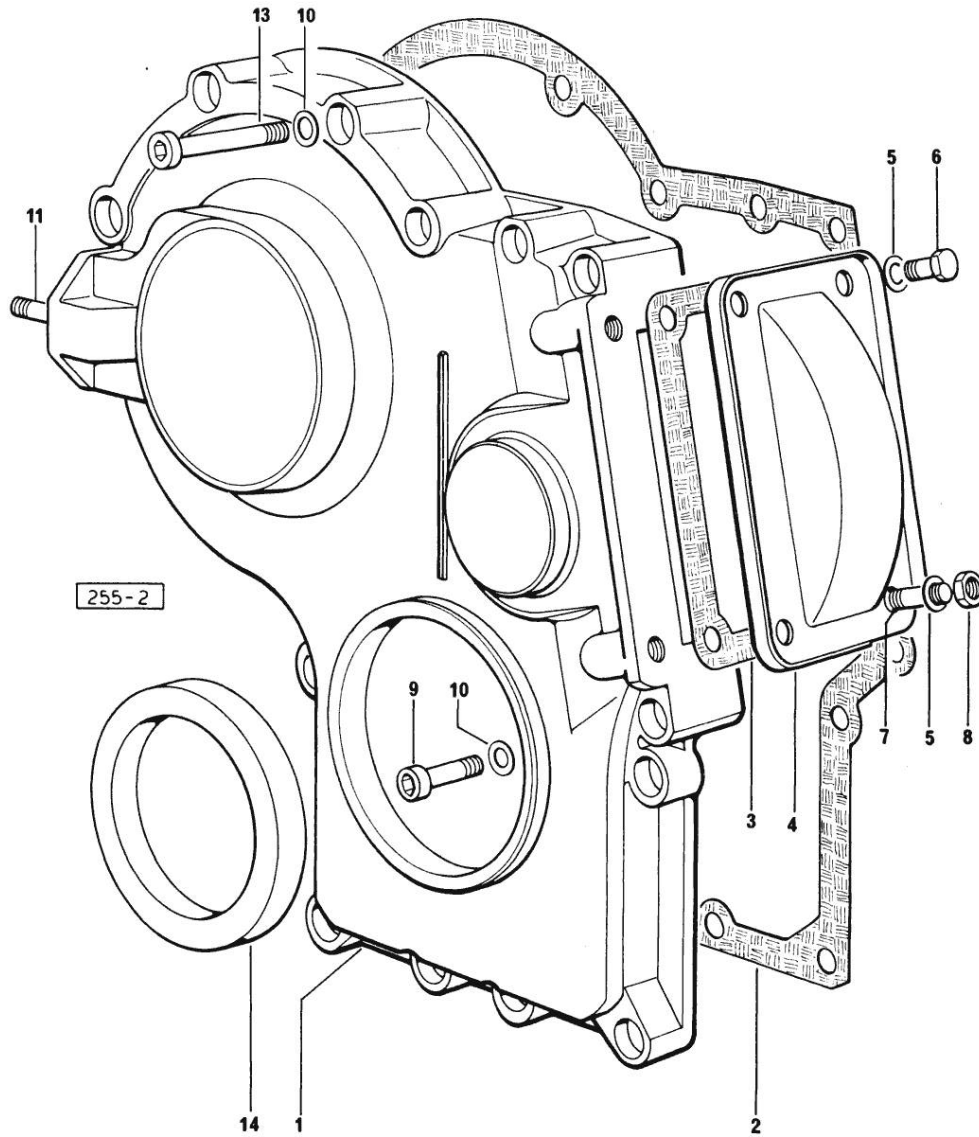

Section: ENGINE

CRANKSHAFT

Fig.	P/n	QTY	Name
Notes:			
[774-80]			
1	0.066.1210.3/20	1	crankshaft X 916.4 W
1	0.086.1210.3	1	crankshaft X 1000.4 W
2	0.065.1211.0/10	1	crown wheel
3	2.1630.608.0	1	pin 6x16
4	2.3130.001.1	11	plug 1/8" gas
5	0.065.1220.3/10	4	engine connecting rod X 916.4 W
5	0.078.1220.3/10	4	engine connecting rod - X 1000.4 W X 1000.4 W
6	2.0139.021.0	8	screw
7	0.065.1227.0	4	special bushing X 916.4 W
7	2.1559.114.0/10	4	special bushing X 1000.4 W
8	2.1411.013.1	8	circlip 32 X 916.4 W
8	2.1411.014.1	8	circlip 35 X 1000.4 W
9	0.065.1236.0	4	piston pin X 916.4 W
9	0.078.1236.0	4	piston pin Ø 18 / Ø 35 / L = mm 86 X 1000.4 W
10	2.1720.006.0	2	key 4x6.5
11	0.065.1248.0	1	old part number
13	2.0399.095.2	1	old part number
14	2.1599.503.2	1	shoulder ring
15	2.0112.317.2	6	screw m 10 p.1.5 x 45
15	2.0112.320.2	6	screw m 10 p.1.5 x 55
16	2.1470.006.2	6	lock washer 10
17	0.066.1244.0	1	pulley 2245<=
17	0.066.1244.0/10	1	pulley =>2246
17	0.075.1252.0	1	pulley 70x188x77,7 - FOR TRACTORS WITH AIR CONDITIONING
18	0.065.1254.0	1	gasket
19	0.065.1253.0/10	1	cover
20	2.1529.073.0	1	special oil seal 110x130x13
21	2.0112.207.2	9	screw m 8 p 1.25 x 20

Section: ENGINE
CRANKSHAFT

Fig.	P/n	QTY	Name
22	2.1474.009.2	9	spring washer 8
23	0.065.1225.0	8	con.rod half bushing STANDARD - A = 28.75 -> 29.00
23	0.065.1225.7	8	con.rod half bushing - mm 0.25
23	0.065.1225.8	8	con.rod half bushing - mm 0.50
24	0.065.1215.0	5	main half bushing STANDARD
24	0.065.1215.7	5	main half bushing - mm 0.25
24	0.065.1215.8	5	main half bushing - mm 0.50
25	0.065.1216.0	5	main half bushing
25	0.065.1216.7	5	main half bushing - mm 0.25
25	0.065.1216.8	5	main half bushing - mm 0.50
26	0.065.1218.0	4	shim STANDARD
26	0.065.1218.7	4	shim + mm 0.10
26	0.065.1218.8	4	shim + mm 0.15
27	0.066.0060.6	4	complete piston X 916.4 W
27	0.085.0060.6	4	complete piston X 1000.4 W
28	0.065.0052.6	4	piston ring set X 916.4 W
28	0.085.0052.6	4	piston ring set X 1000.4 W
29	2.0139.022.2	6	screw m 12 p.1.25x55
30	0.076.1247.3/10	1	flywheel
31	0.065.1242.0	1	crown wheel Z = 123
32	0.255.2525.0/10	1	flange
34	2.1652.915.0	1	cylindrical plug 12x35

Section: ENGINE
COUNTERWEIGHTS

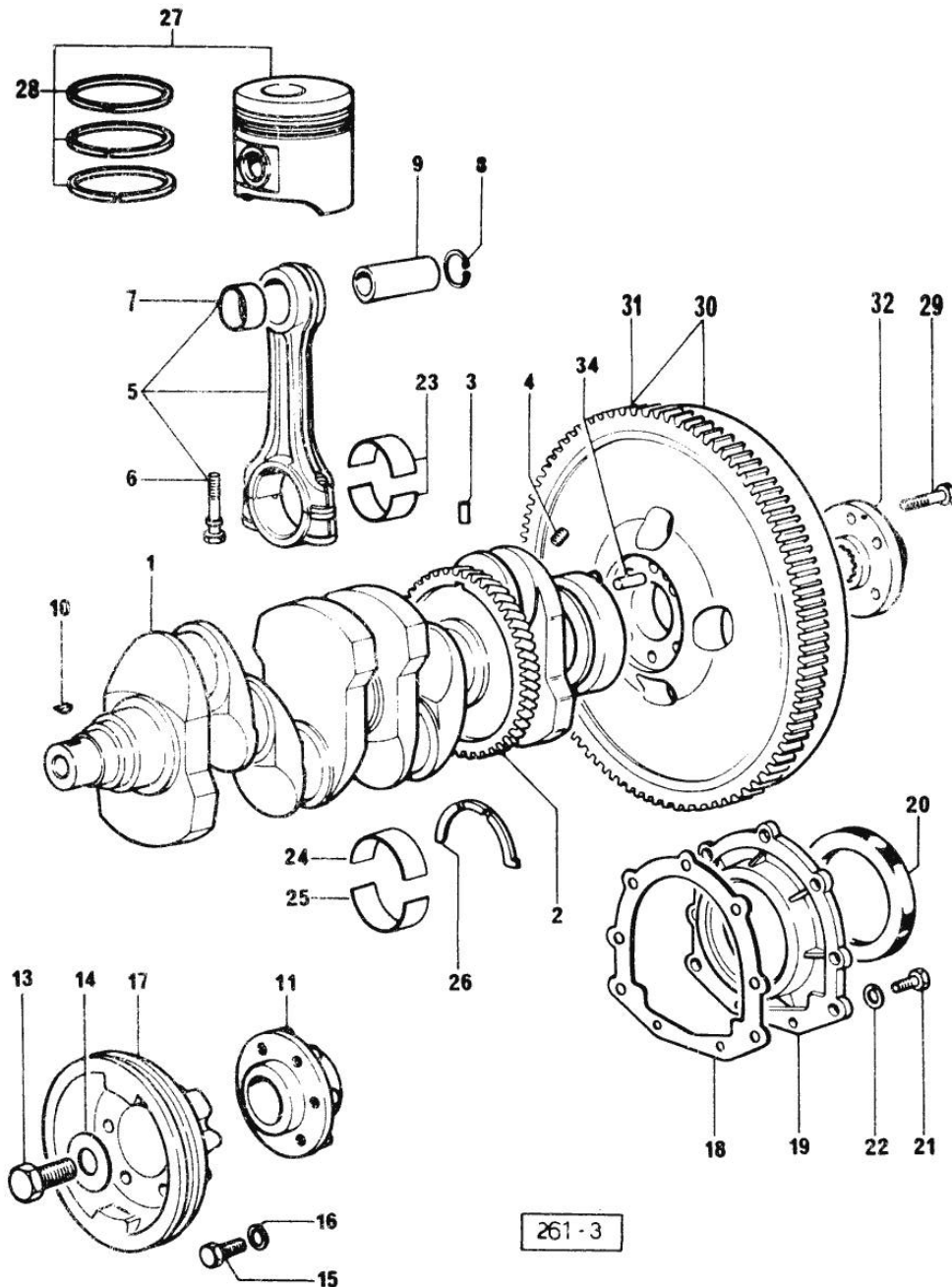
Notes:
 [774-80]

Fig.	P/n	QTY	Name
1	0.065.1232.3/20	1	old part number X 916.4 W
1	0.086.1233.3/10	1	mass X 1000.4 W
2	2.1559.115.0	2	special bushing 26x30x30
3	2.1652.302.0	1	roll pin 4x6
4	0.065.1237.0/10	1	gear
5	0.065.1233.3/10	1	mass
6	2.1410.018.1	1	circlip 45
7	2.1652.302.0	1	roll pin 4x6
8	2.1559.115.0	2	special bushing 26x30x30
9	0.065.1238.0	1	gear
10	2.1589.050.0	4	shim X 916.4 W
10	2.1589.185.0	4	shoulder ring 26.1x34x1 X 1000.4 W
11	2.1631.717.0	2	roll pin 8 x 40
12	0.065.1231.3/20	1	old part number X 916.4 W
12	0.086.1231.3	1	old part number X 1000.4 W
13	2.3130.001.1	4	plug 1/8" gas
14	2.0112.427.1	4	screw m 12 p.1.75 x 90
15	2.1589.048.0	2	shoulder ring 16.5x26x0.3
15	2.1589.049.0	2	shoulder ring 12.5x26x0.3
16	2.1579.628.0	2	spacer 16.5x26x0.1
16	2.1579.629.0	2	spacer 12.5x26x0.1
17	2.1579.626.0	2	spacer 13.2x16x11
18	2.1589.139.0	2	shoulder ring mm 0.3
19	2.1589.140.0	2	shoulder ring mm 0.1
20	2.1699.191.0	1	bush 7x10x16
21	0.065.1234.3	2	old part number
22	2.3130.001.1	2	plug 1/8" gas

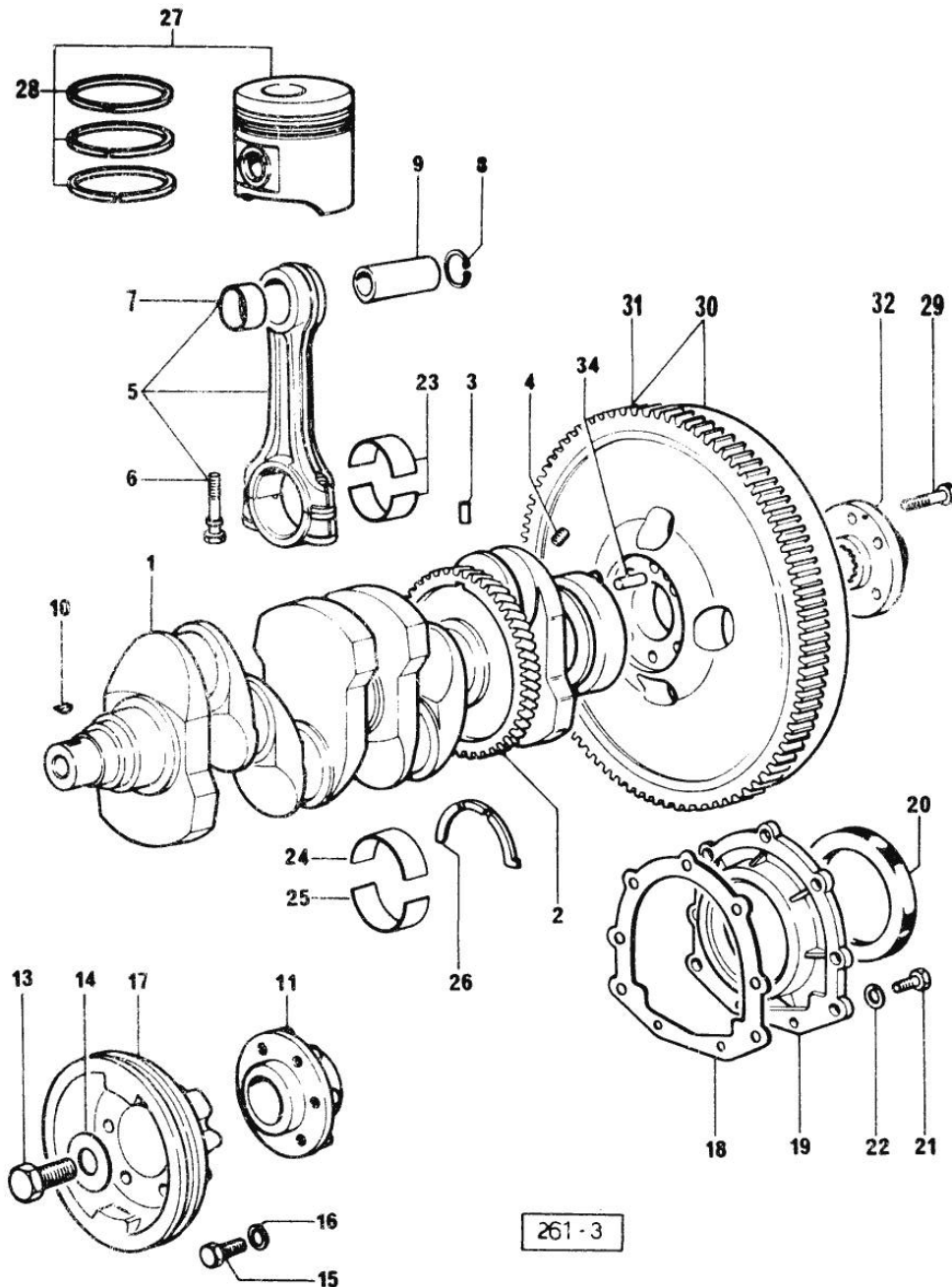
Section: ENGINE

CAMSHAFT

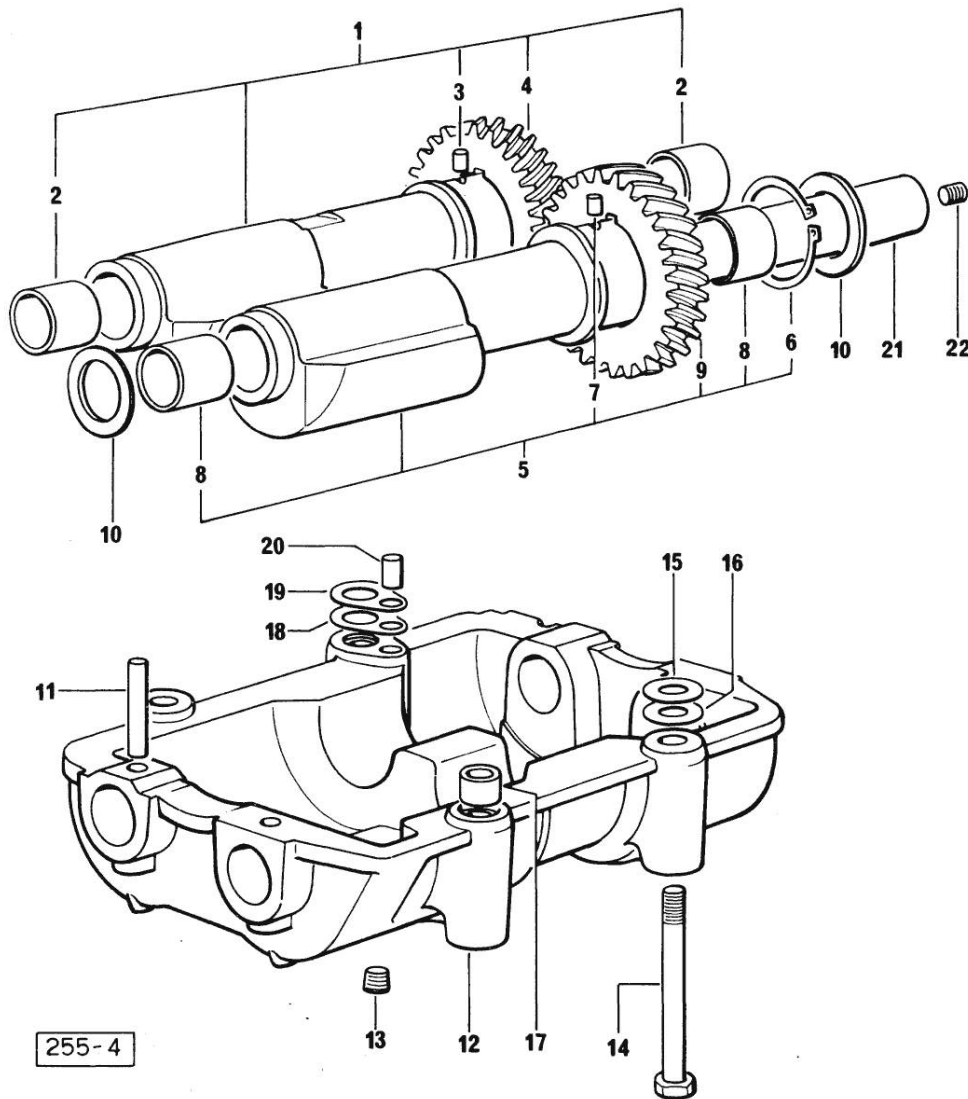
Fig.	P/n	QTY	Name
------	-----	-----	------

Notes:

[774-80]

1	0.065.1324.0	1	gear
1	0.066.1310.3/20	1	camshaft
2	0.065.1353.0	1	small plate
3	2.0312.205.2	2	screw
4	2.1480.014.1	2	washer 8
5	065.1323.0/20	1	-
6	065.1325.3/20	1	-
6	2.1559.185.0/10	1	bushing
7	0.065.1351.0	2	shoulder ring
8	0.065.1352.0	1	shim
9	2.1410.016.1	1	circlip 40
10	0.065.1354.0/10	1	gear z=58
11	0.065.1350.0	1	small disc
12	2.0132.207.2	4	screw m 10 p.1 x 25
13	0.065.1330.0	8	tappets
14	2.1569.114.0	16	gasket
15	2.1599.437.0	8	shoulder ring
16	2.4019.300.1	8	spring
17	0.065.1332.0	8	sleeve
18	0.065.1331.2	8	rod

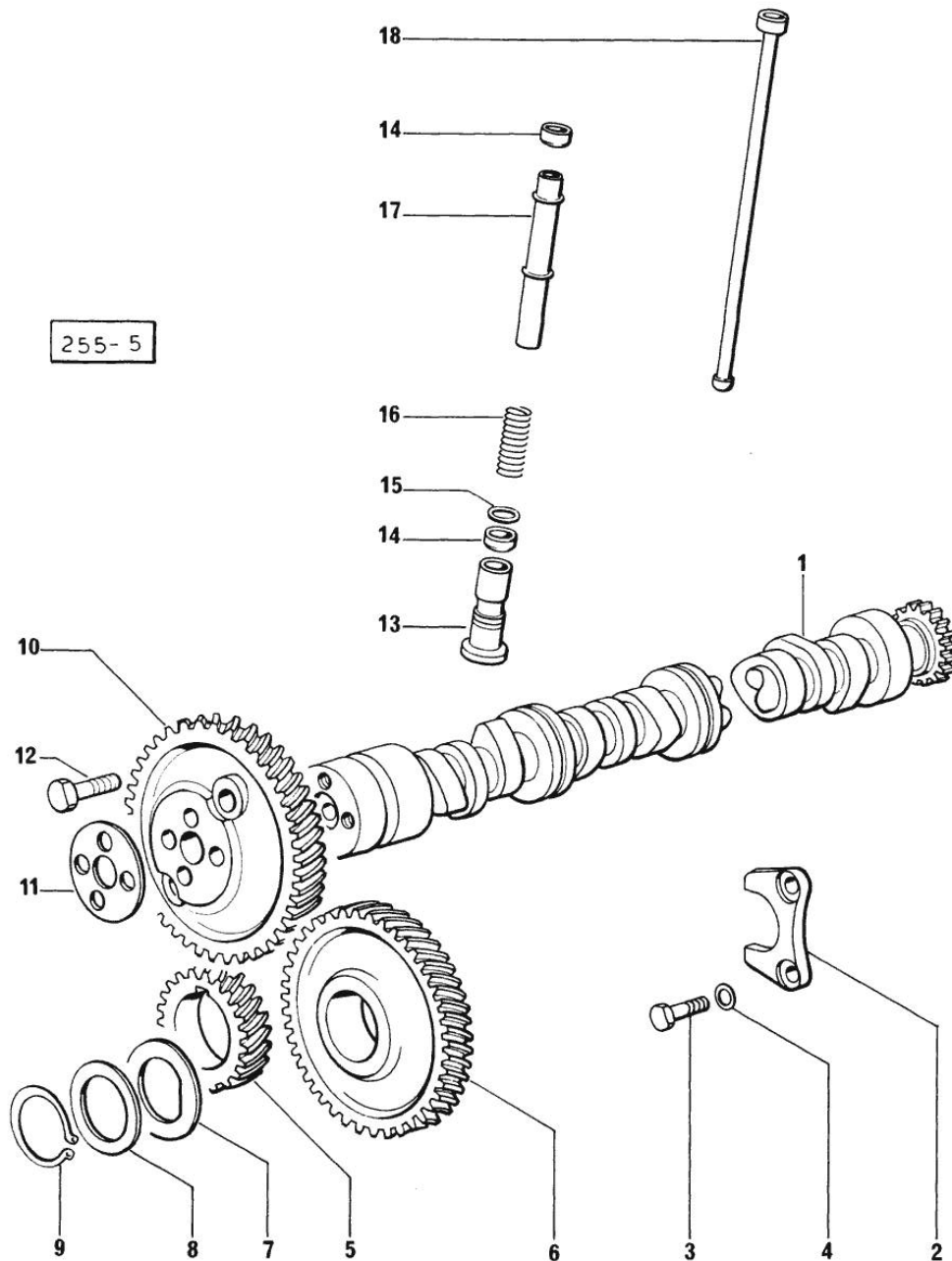

Buy Now



Our support email:

ebooklibonline@outlook.com