

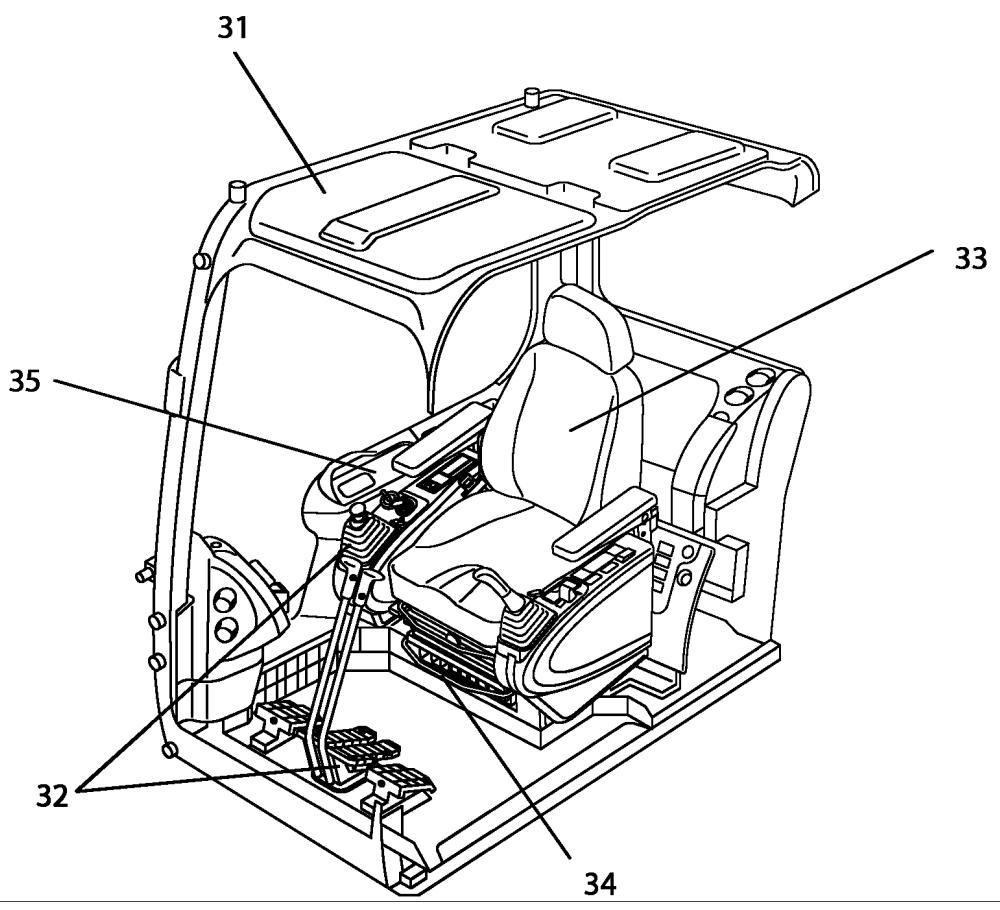

# PARTS CATALOGUE

CRAWLER EXCAVATOR  
CX240B

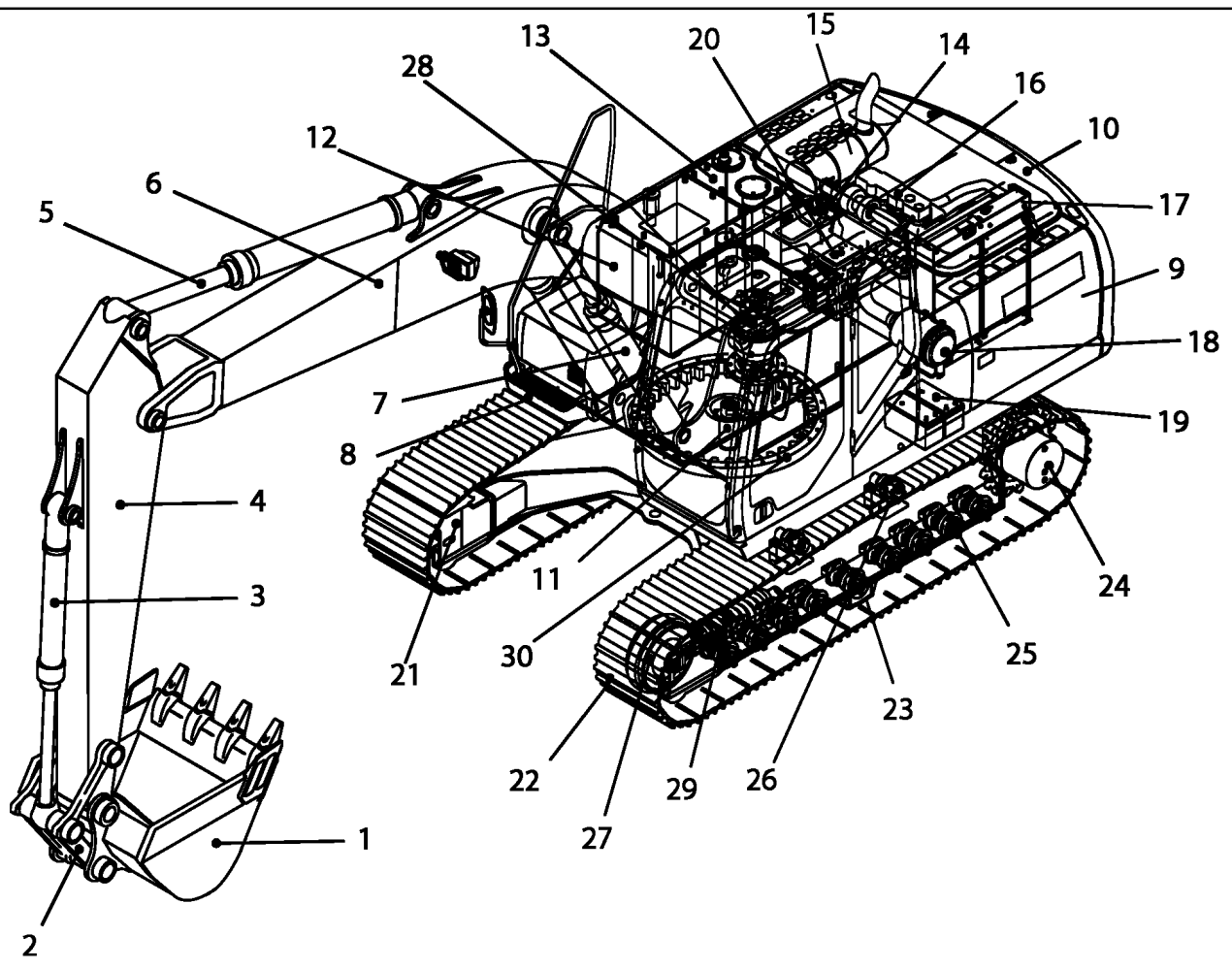

## CX240B CASE CRAWLER EXCAVATOR TIER III (EUROPE) (1/07- )

## 00-001-00(01) COMPONENT INDEX

Ref	Part Number	Qty	Description
1		1	BUCKET - See Figure(s) 09-310-00 01 - 09-322-00 01
2		1	BUCKET CONTROL - See Figure(s) 09-300-00 01
3		1	BUCKET CYLINDER - See Figure(s) 08-021-00 01, 08-303-00 01
4		1	DIPPER - See Figure(s) 09-202-00 01
5		1	DIPPER CYLINDER - See Figures 08-017-00 01, 08-018-00 01, 08-302-00 1, 08-302-01 01
6		1	MONOBLOCK BOOM - See Figure(s) 09-100-00 01
7		1	BOOM CYLINDER - See Figure(s) 08-013-00 01 - 08-015-00 01, 08-300-00 01 - 08-301-01 01
8		1	UPPERSTRUCTURE CHASSIS - See Figure(s) 09-002-00 01, 09-003-00 01
9		1	COWLING - See Figure(s) 09-005-00 01 - 09-008-00 01
10		1	COUNTERWEIGHT - See Figure(s) 09-004-00 01
11		1	SWING JOINT - See Figure(s) 07-010-00 01
12		1	FUEL TANK, FUEL SYSTEM - See Figure(s) 03-001-00 01 - 03-086-01 01
13		1	HYDRAULIC RESERVOIR, HYDRAULIC SYSTEM - See Figure(s) 08-001-00 01, 08-004-00 01 To 08-067-00 01
14		1	HYDRAULIC PUMP - See Figure(s) 08-002-00 01, 08-002-01 01
15		1	EXHAUST ENGINE - See Figure(s) 02-003-00 01
16		1	ENGINE - See Figure(s) 02-001-00 01, 02-005-01 01 - 02-286-01 01
17		1	RADIATOR - See Figure(s) 02-004-00 01, 02-004-01 01
18		1	AIR FILTRATION - See Figure(s) 02-002-00 01
19		1	BATTERIES, ELECTRICAL SYSTEM - See Figure(s) 04-001-00 01 - 04-815-01 01
20		1	CONTROL VALVE - See Figure(s) 08-200-00 01 - 08-212-00 01
21		1	UNDERCARRIAGE, HYDRAULIC CIRCUIT For CX240B LC - See Figure(s) 05-001-00 01, 07-001-00 01
21		1	UNDERCARRIAGE, HYDRAULIC CIRCUIT For CX240B NLC - See Figure(s) 05-001-01 01, 07-001-01 01
22		1	TRACK FOOT STEP - See Figure(s) 05-006-00 01 - 05-009-00 01
23		1	GUIDE, CHAIN - See Figure(s) 05-011-00 01, 05-011-01 01
24		1	TRAVEL MOTOR AND REDUCTIONGEAR - See Figure(s) 06-001-00 01, 06-010-00 01, 07-011-00 01 07-012-00 01
25		1	ROLLER LOWER - See Figure(s) 05-003-00 01
26		1	ROLLER UPPER - See Figure(s) 05-002-00 01
27		1	GUIDE PULLEY - See Figure(s) 05-004-00 01
28		1	SWING MOTOR-DRIVE REDUCTION GEAR - See Figure(s) 06-002-00 01, 06-011-00 01, 08-220-00 01
29		1	TENSION DAMPER - See Figure(s) 05-005-00 01
30		1	SWING COMPONENTS, LUBRICATION CIRCUIT - See Figure(s) 09-001-00 01
31		1	OPERATORS COMPARTMENT, CAB - See Figure(s) 09-029-00 01 - 09-032-00 01
32		1	OPERATORS COMPARTMENT, LEVER, CONTROL - See Figure(s) 09-009-00 01
33		1	OPERATORS COMPARTMENT - SEAT AND CONTROL ARM MOUNTING - See Figure(s) 09-017-00 01 - 09-023-00 01
34		1	CAB AIR CONDITIONING - See Figure(s) 09-025-00 01 - 09-028-00 01
35		1	SIDE INSTRUMENT PANEL - See Figure(s) 09-029-00 01

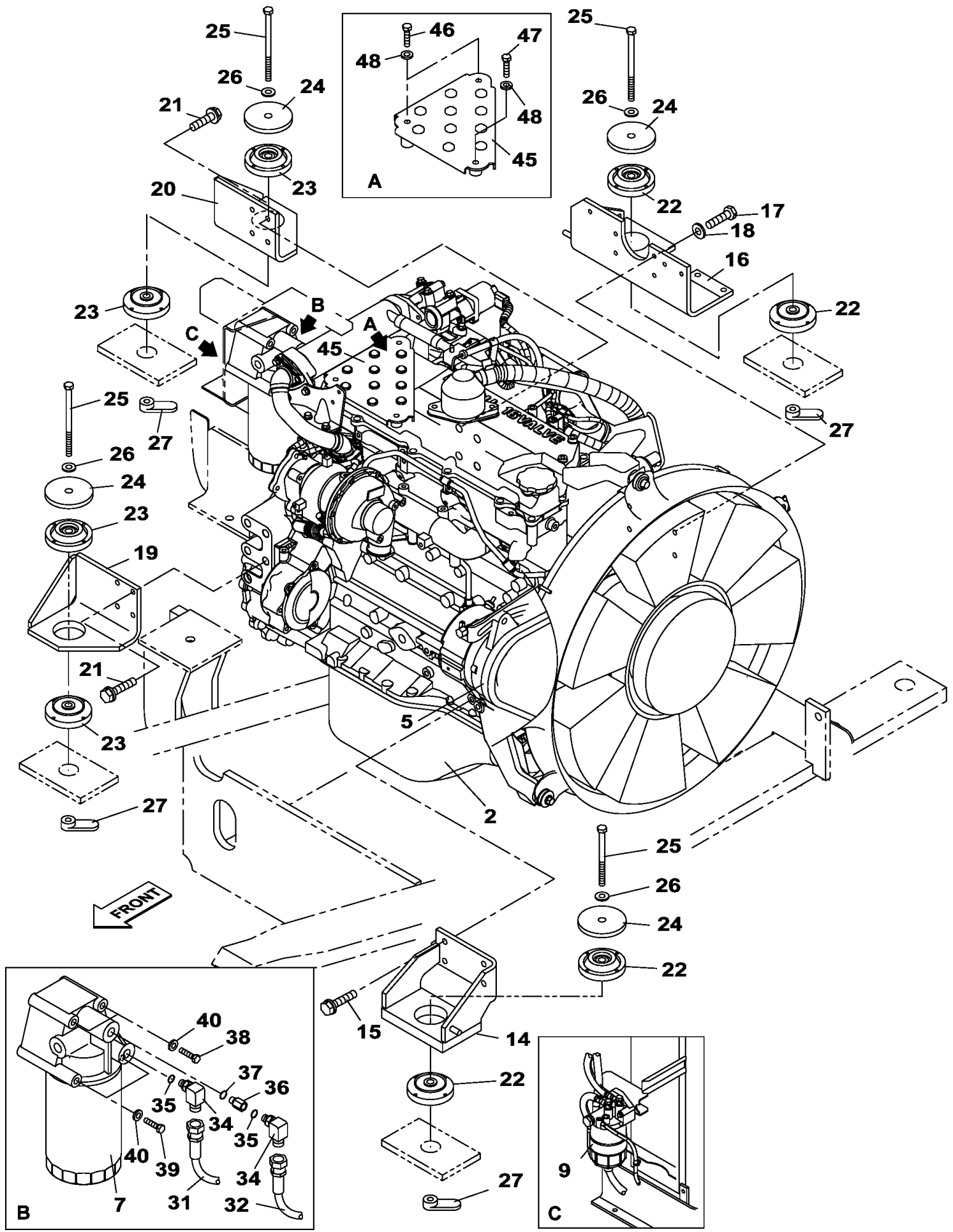

## CX240B CASE CRAWLER EXCAVATOR TIER III (EUROPE) (1/07- )

## 02-001-00(01) ENGINE MOUNTING - ENGINE - OIL CIRCUIT

Ref	Part Number	Qty	Description
2	KBH10790	1	ENGINE, , See Figure(s) 02-001-01 01
5	REF	1	INSTRUCTION, Belt, See Figure(s) 02-033-01 01, Ref. 36
7	REF	1	INSTRUCTION, Oil Filter, See Figure(s) 02-050 01 01, Ref. 496
9	REF	1	INSTRUCTION, Fuel Filter, See Figure(s) 03-041-01 01, Ref. 1A
14	KRH10990	1	SUPPORT,
15	166347A1	4	BOLT, M10 x 30
16	KRH11000	1	SUPPORT,
17	627-10035	5	BOLT, Hex, M10 x 35, 10.9, Full Thd, M10 x 35; 10.9
18	150409A1	5	WASHER,
19	KRH10130	1	SUPPORT,
20	KRH10140	1	SUPPORT,
21	166373A1	8	BOLT, M16 x 40
22	KRH10870	4	SILENTBLOC,
23	KRH10860	4	SILENTBLOC,
24	KRH10190	4	PLATE,
25	827-16130	4	BOLT, Hex, M16 x 130, 10.9, M16 x 130; 10.9
26	150814A1	4	WASHER,
27	KRH1251	4	NUT,
34	157580A1	2	ELBOW, 90°, 3/4" O-Ring x 3/4", , Include(s) 35
35	154503A1	1	O-RING,
36	152012A1	1	CONNECTOR, , Include(s) 37
37	154503A1	1	O-RING,
38	102R008Y110R	2	BOLT, M8 x 110
39	KHH0515	2	BOLT, M8 x 140
40	153081A1	4	WASHER,
45	KRH11050	1	STEP,
46	827-8070	2	BOLT, Hex, M8 x 70, 10.9, M8 x 70; 10.9
47	827-8040	1	BOLT, Hex, M8 x 40, 10.9, M8 x 40; 10.9
48	153081A1	3	WASHER,

Thank you so much for reading.  
Please click the “Buy Now!”  
button below to download the  
complete manual.



After you pay.

You can download the most  
perfect and complete manual in  
the world immediately.

Our support email:

[ebooklibonline@outlook.com](mailto:ebooklibonline@outlook.com)