

100

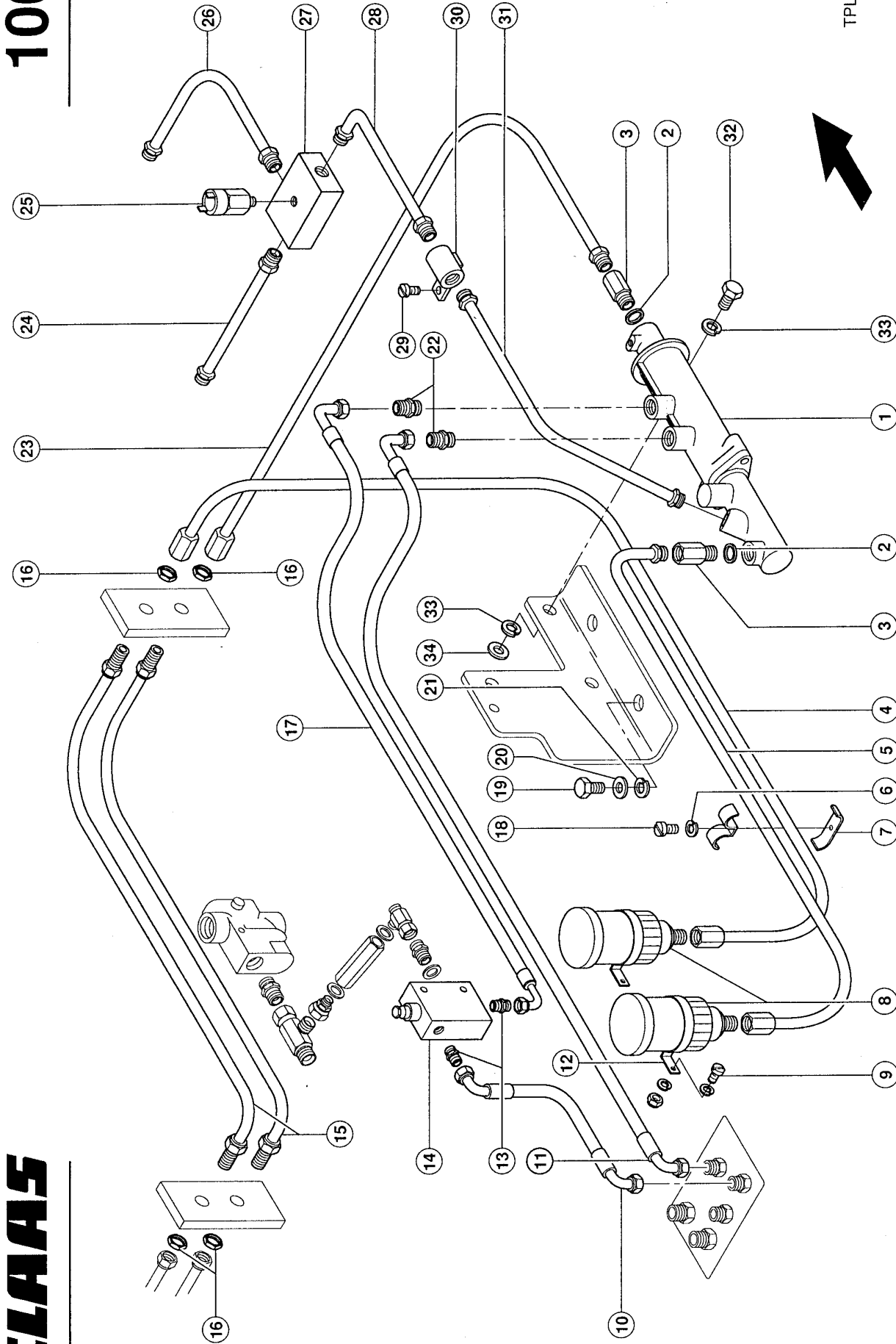

TPL60252

Ranger 925



CLAAS

119000

BRAKE CIRCUIT 1)

Pos.	Part No.	Description	Dimension	Quantity	Conditions
1	00 0310 026 0	TRANSMITT.CYL.ASS		1	2)
2	00 0321 446 0	SEAL RING		1	
3	00 0326 193 0	ADAPTER	I-M12X1,5 - A-A-M14X1,5	1	
3	00 0326 193 0	ADAPTER	I-M12X1,5 - A-A-M14X1,5	1	
4	00 0314 340 0	BRAKE PIPE		1	
5	00 0314 467 0	BRAKE PIPE		1	
6	00 0320 190 0	WASHER	M06	1	
7	00 0326 444 0	PIPE CLAMP		1	
8	00 0324 140 0	CONTAINER		2	
9	00 0320 102 0	HEXAGON HEAD SCREW	M 5X16	4	
9	00 0320 198 0	SPRING WASHER	M04	8	
9	00 0320 315 0	NUT	M.5	4	
10	00 0313 757 0	HOSE		1	
11	00 0314 743 0	HOSE		1	
12	00 0326 482 0	CLAMP		2	
13	00 0326 454 0	ADAPTER	L12 E-G	2	
14	00 0324 135 0	PRESS.REDUCER VAL		1	3)
14	00 0315 572 0	SEAL KIT		1	
15	00 0326 490 0	BRAKE HOSE		2	
16	00 0326 392 0	NUT	M12X1	4	
17	00 0326 539 0	HOSE		1	
18	00 0320 115 0	SCREW	M6X10	1	
19	00 0236 056 0	HEXAGON HEAD BOLT	M12X25	2	
20	00 0320 194 0	SPRING WASHER	M12	2	
21	00 0320 235 0	WASHER	M12	2	
22	00 0310 192 0	SOCKET	SDS-S10XM16X1, 5-TYPE F 6X?X700-0	2	
23	00 0326 279 0	BRAKE PIPE		1	
24	00 0326 265 0	BRAKE PIPE		1	
25	00 0324 048 0	PRESSURE SWITCH	L=46/ SW 24	1	4)
25	00 0342 492 0	PRESSURE SWITCH	L=46/ SW 24	1	5)
25	00 0342 084 0	REDUCING ADAPTER		1	6)
26	00 0326 264 0	BRAKE PIPE	8X?X200-2	1	
27	00 0326 529 0	HOSE		1	
28	00 0326 283 0	BRAKE PIPE	8X?X710-0	1	
29	00 0320 120 0	SCREW	M8X30	1	
30	00 0324 215 0	CONNECTION		1	
31	00 0326 282 0	BRAKE PIPE		1	
32	00 0320 125 0	SCREW	M10X30	1	
33	00 0320 234 0	WASHER	M10	2	
34	00 0235 133 1	SPRING WASHER	10 -10,2X18,1X1,8	1	

1)	Remarks	with Ranger 925
2)	Remarks	see illustration plate 103
3)	Remarks	23 bar
4)	Remarks	5 bar, see illustration plate 502
5)	Remarks	22 bar
6)	Remarks	for 22 bar

101

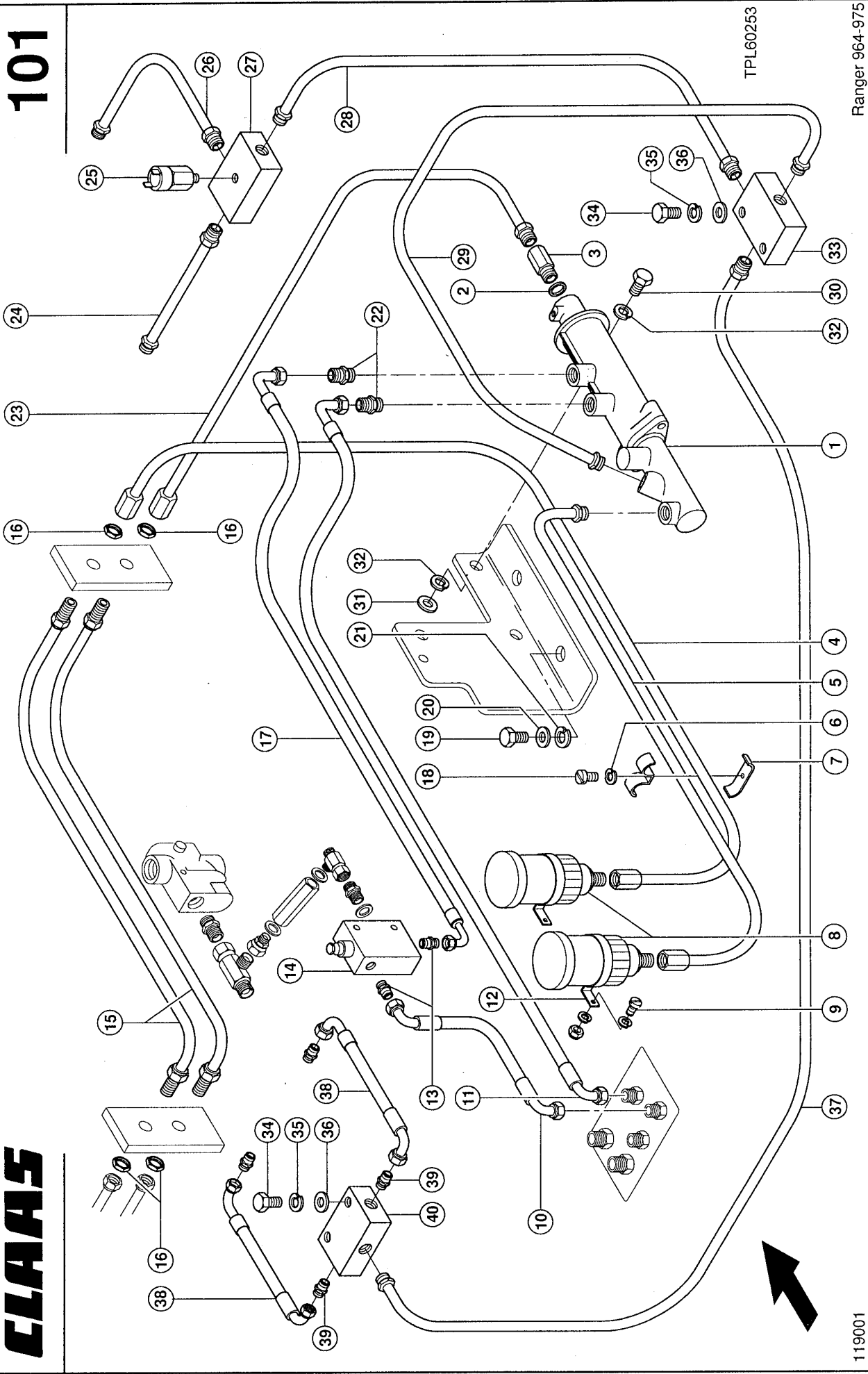

TPL60253

Ranger: 964-975

CLAAS



119001

BRAKE CIRCUIT 1)

Pos.	Part No.	Description	Dimension	Quantity	Conditions
1	00 0324 046 0	TRANSMITT.CYL.ASS		1	2)
2	00 0321 446 0	SEAL RING		1	
3	00 0326 193 0	ADAPTER	I-M12X1,5 - A-A-M14X1,5	1	
4	00 0314 579 0	BRAKE PIPE		1	
5	00 0314 580 0	BRAKE PIPE		1	
6	00 0320 190 0	WASHER	M06	1	
7	00 0326 444 0	PIPE CLAMP		1	
8	00 0324 140 0	CONTAINER		2	
9	00 0320 102 0	HEXAGON HEAD SCREW	M 5X16	4	
9	00 0320 198 0	SPRING WASHER	M04	8	
9	00 0320 315 0	NUT	M.5	4	
10	00 0313 757 0	HOSE		1	
11	00 0313 703 0	HOSE	1/4" BORE	1	
12	00 0326 482 0	CLAMP		2	
13	00 0326 454 0	ADAPTER	L12 E-G	2	
14	00 0324 135 0	PRESS.REDUCER VAL		1	3)
14	00 0315 572 0	SEAL KIT		1	
15	00 0326 490 0	BRAKE HOSE		2	
16	00 0326 392 0	NUT	M12X1	4	
17	00 0313 757 0	HOSE		1	
18	00 0320 115 0	SCREW	M6X10	1	
19	00 0236 056 0	HEXAGON HEAD BOLT	M12X25	2	
20	00 0320 194 0	SPRING WASHER	M12	2	
21	00 0320 235 0	WASHER	M12	2	
22	00 0310 192 0	SOCKET	SDS-S10XM16X1, 5-TYPE F	2	
23	00 0326 489 0	BRAKE HOSE	1SN 6 P90(S08)P(S08) 370	1	
24	00 0326 265 0	BRAKE PIPE		1	
25	00 0324 048 0	PRESSURE SWITCH	L=46/ SW 24	1	
26	00 0326 264 0	BRAKE PIPE	8X?X200-2	1	
27	00 0326 259 0	DISTRIBUTOR BLOCK	3 X B-I-M14X1,5 + 1/8 1 NP	1	
28	00 0311 845 0	BRAKE PIPE	8X?X1100-?	1	
29	00 0311 844 0	BRAKE PIPE	8X?X710-?	1	
30	00 0320 125 0	SCREW	M10X30	1	
31	00 0320 234 0	WASHER	M10	2	
32	00 0235 133 1	SPRING WASHER	10 -10,2X18,1X1,8	1	
33	00 0326 256 0	DISTRIBUTOR BLOCK	3 X B-I-M14X1,5	1	
34	00 0324 996 0	HEXAGON HEAD SCREW	M8X35	3	
35	00 0320 191 0	SPRING WASHER	M08	3	
36	00 0320 233 0	WASHER	M08	3	
37	00 0314 312 0	BRAKE PIPE		1	
38	00 0326 489 0	BRAKE HOSE	1SN 6 P90(S08)P(S08) 370	2	
39	00 0326 449 0	ADAPTER	S08 E-M14	4	
40	00 0315 077 0	DISTRIBUTOR BLOCK		1	

1) Remarks with Ranger 964-975

2) Remarks see illustration plate 103

3) Remarks 23 bar

102

Ranger 925 - 975

BR-073

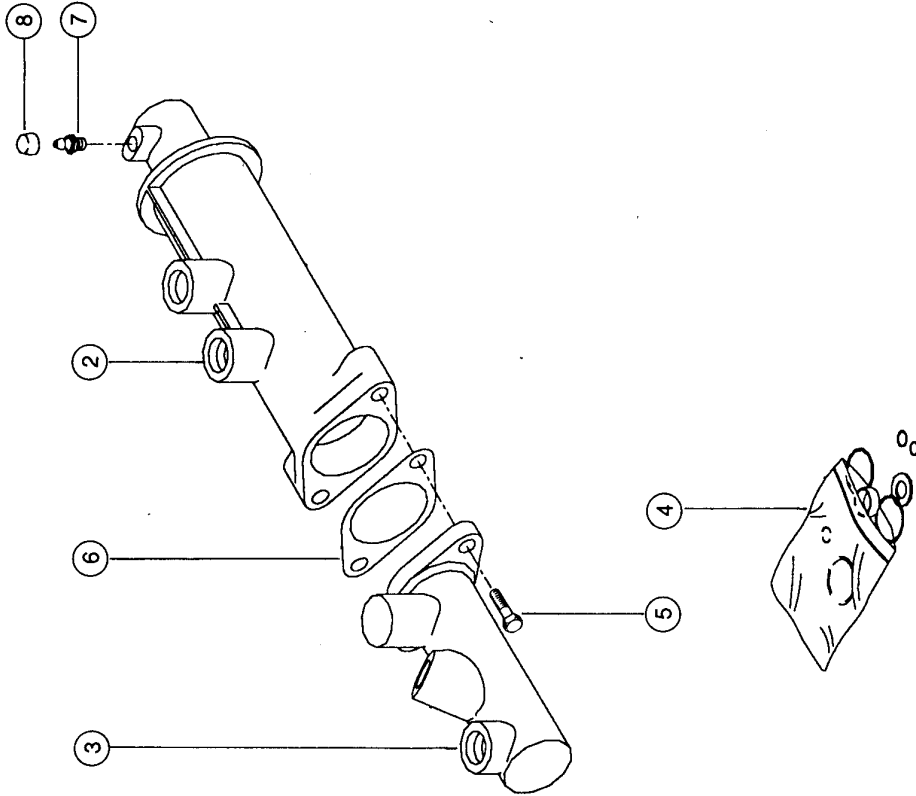

CLAAS

119023



BRAKE BOOSTER

Pos.	Part No.	Description	Dimension	Quantity	Conditions
1	00 0324 046 0	TRANSMITT.CYL.ASS		1	1)
1	00 0310 026 0	TRANSMITT.CYL.ASS		1	2)
2	00 0326 158 0	BRAKE EFF.CONTR.		1	
3	00 0326 159 0	MASTER CYLINDER		1	3)
3	00 0327 018 0	MASTER CYLINDER	7/8"	1	4)
4	00 0326 154 0	SEAL KIT		1	1)
4	00 0327 027 0	SEAL KIT		1	2)
5	00 0326 160 0	SCREW		2	
6	00 0326 161 0	SHIM	0,5 STAINLESS	1	5)
7	00 0326 162 0	GREASE NIPPLE		1	
8	00 0326 163 0	GUARD CAP		1	

1) Remarks	Ranger 964-975
2) Remarks	Ranger 925
3) Remarks	Ranger 964-975 D=25.4
4) Remarks	Ranger 925 D=22,25
5) Remarks	0.5 mm thick

103

CLAAS

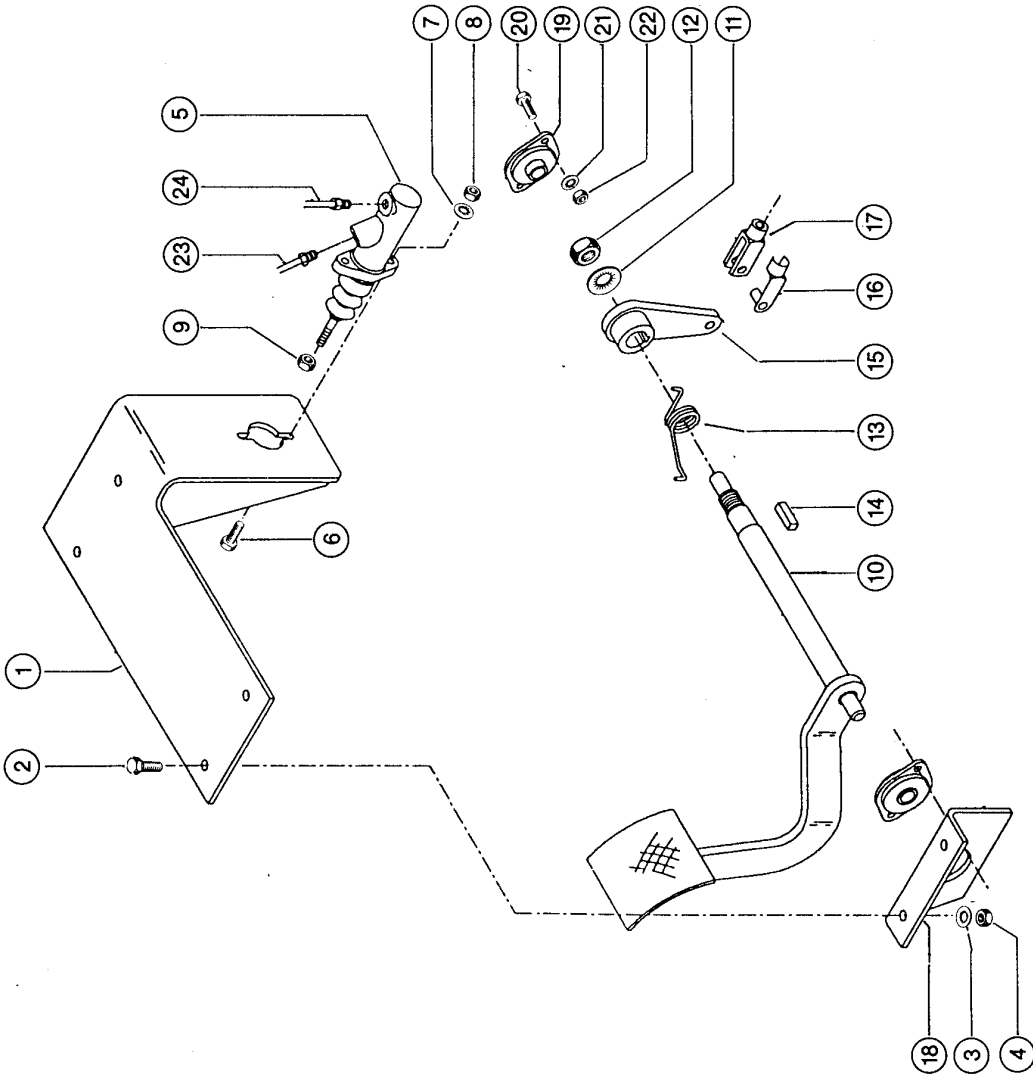

BR-070

Ranger 925

119024

BRAKE PEDAL - FOOT OPERATED 1)

Pos.	Part No.	Description	Dimension	Quantity	Conditions
1	00 0326 276 0	SUPPORT		1	
2	00 0320 125 0	SCREW	M10X30	4	
3	00 0320 192 0	WASHER	M10	4	
4	00 0320 318 0	NUT	M10	4	
5	00 0324 049 0	BRAKE CYLINDER		1	
5	00 0324 050 0	REPAIR KIT		1	2)
6	00 0320 120 0	SCREW	M8X30	2	
7	00 0320 191 0	SPRING WASHER	M08	2	
8	00 0320 317 0	NUT	M 8	2	
9	00 0320 365 0	NUT		2	
10	00 0326 274 0	BRAKE PEDAL		1	
11	00 0320 237 0	WASHER	M20	1	
12	00 0237 521 0	HEX.NUT	M20	1	
13	00 0326 480 0	TORSION SPRING		1	
14	00 0326 419 0	PARALLEL KEY	8X7 X25 ERS.D. 600500451	1	
15	00 0326 263 0	LEVER ARM		1	
16	00 0326 194 0	PIN		1	
17	00 0326 275 0	FORK HEAD		1	
18	00 0326 290 0	BEARING BRACKET		1	
19	00 0326 260 0	FLANGE BEARING		2	
20	00 0320 110 0	SCREW	M6X20	4	
21	00 0320 190 0	WASHER	M06	4	
22	00 0323 222 0	NUT	M 6	4	
23	00 0326 280 0	BRAKE PIPE	6X?X550-0	1	
24	00 0326 281 0	BRAKE PIPE	6X?X650-0	1	
1)	Remarks	Up To Serial No. 51000422 With Ranger 925			
2)	Remarks	for Item 5			

104

CLAAS

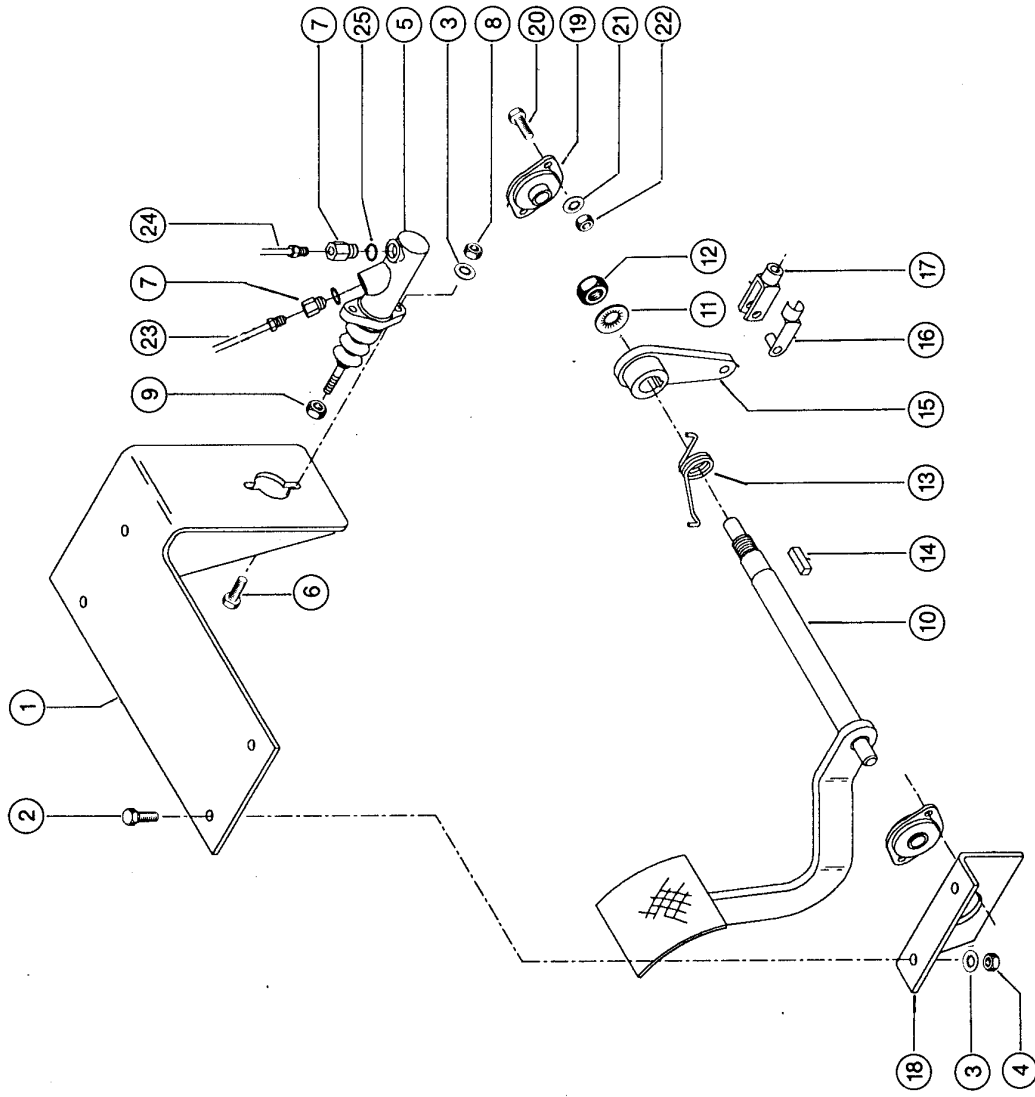

119025

BR-070A

Ranger 964 -- 975

BRAKE PEDAL - FOOT OPERATED 1)

Pos.	Part No.	Description	Dimension	Quantity	Conditions
1	00 0326 262 0	SUPPORT		1	
2	00 0320 125 0	SCREW	M10X30	4	
3	00 0320 192 0	WASHER	M10	6	
4	00 0320 318 0	NUT	M10	4	
5	00 0324 144 0	BRAKE CYLINDER		1	
5	00 0324 047 0	SEAL KIT		1	2)
6	00 0237 874 0	HEXAGON HEAD BOLT	M10X35	2	
7	00 0326 193 0	ADAPTER	I-M12X1,5 - A-A-M14X1,5	2	
8	00 0238 316 0	LOCK NUT	M10	2	
9	00 0320 285 0	SECURING NUT		2	
10	00 0326 274 0	BRAKE PEDAL		1	
11	00 0320 237 0	WASHER	M20	1	
12	00 0237 521 0	HEX.NUT	M20	1	
13	00 0326 480 0	TORSION SPRING		1	
14	00 0326 419 0	PARALLEL KEY	8X7 X25 ERS.D. 600500451	1	
15	00 0326 263 0	LEVER ARM		1	
16	00 0322 768 0	PIN		1	
17	00 0326 483 0	FORK HEAD		1	
18	00 0326 290 0	BEARING BRACKET		1	
19	00 0326 260 0	FLANGE BEARING		2	
20	00 0320 110 0	SCREW	M6X20	4	
21	00 0320 190 0	WASHER	M06	4	
22	00 0323 222 0	NUT	M 6	4	
23	00 0326 280 0	BRAKE PIPE	6X?X550-0	1	
24	00 0326 281 0	BRAKE PIPE	6X?X650-0	1	
25	00 0321 446 0	SEAL RING		2	

1) RemarksUp To Serial No. 51600768
With Ranger 964 - 975**2) Remarks**

for Item 5

104A

Ranger 925-928

EG9934

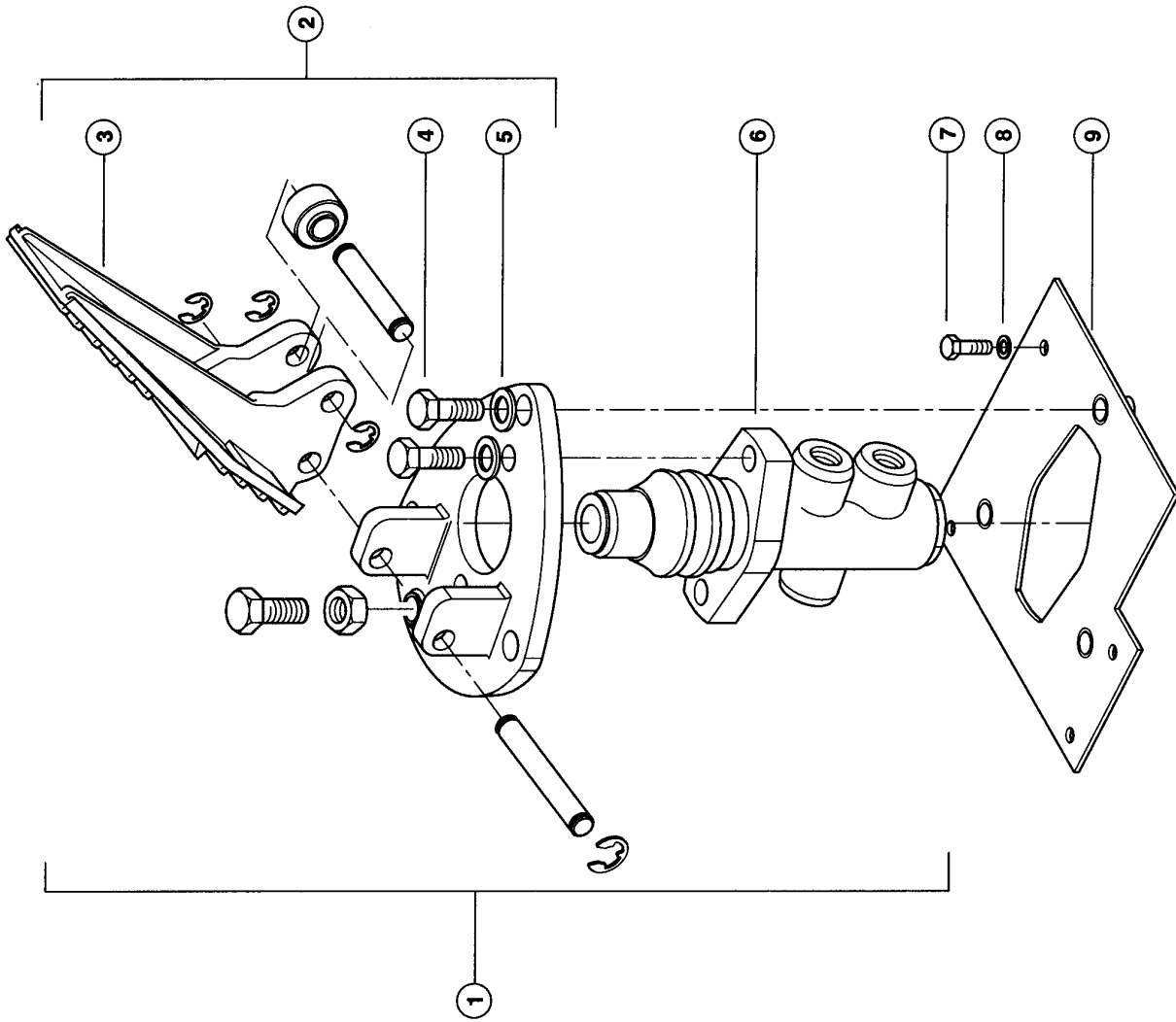

CLAAS

101768

BRAKE PEDAL ASSEMBLY 1)

Pos.	Part No.	Description	Dimension	Quantity	Conditions
1	00 0315 491 0	BRAKE VALVE		1	2)
2	00 0316 895 0	PEDAL CPL.		1	
3	00 0316 894 0	PEDAL		1	
4	00 0236 200 0	HEXAGON HEAD BOLT	M8X20	3	
5	00 0239 387 0	CONTACT WASHER	A8-8,2X18X1,4	3	
6	00 0316 892 0	BRAKE VALVE		1	
6	00 0316 893 0	REPAIR KIT		1	
7	00 0233 918 0	HEXAGON HEAD BOLT	M 5X16	4	
8	00 0217 014 0	CONTACT WASHER	A 5- 5,1X12X1,1	4	
9	00 0315 217 0	METAL SPACER		1	

1) Remarks

From Serial No. 51000423
From Serial No. 51600769
See Illustration 104 E

2) Remarks

with Item 2 - 6

104B

CLAAS

Ranger 925-928

EG9829

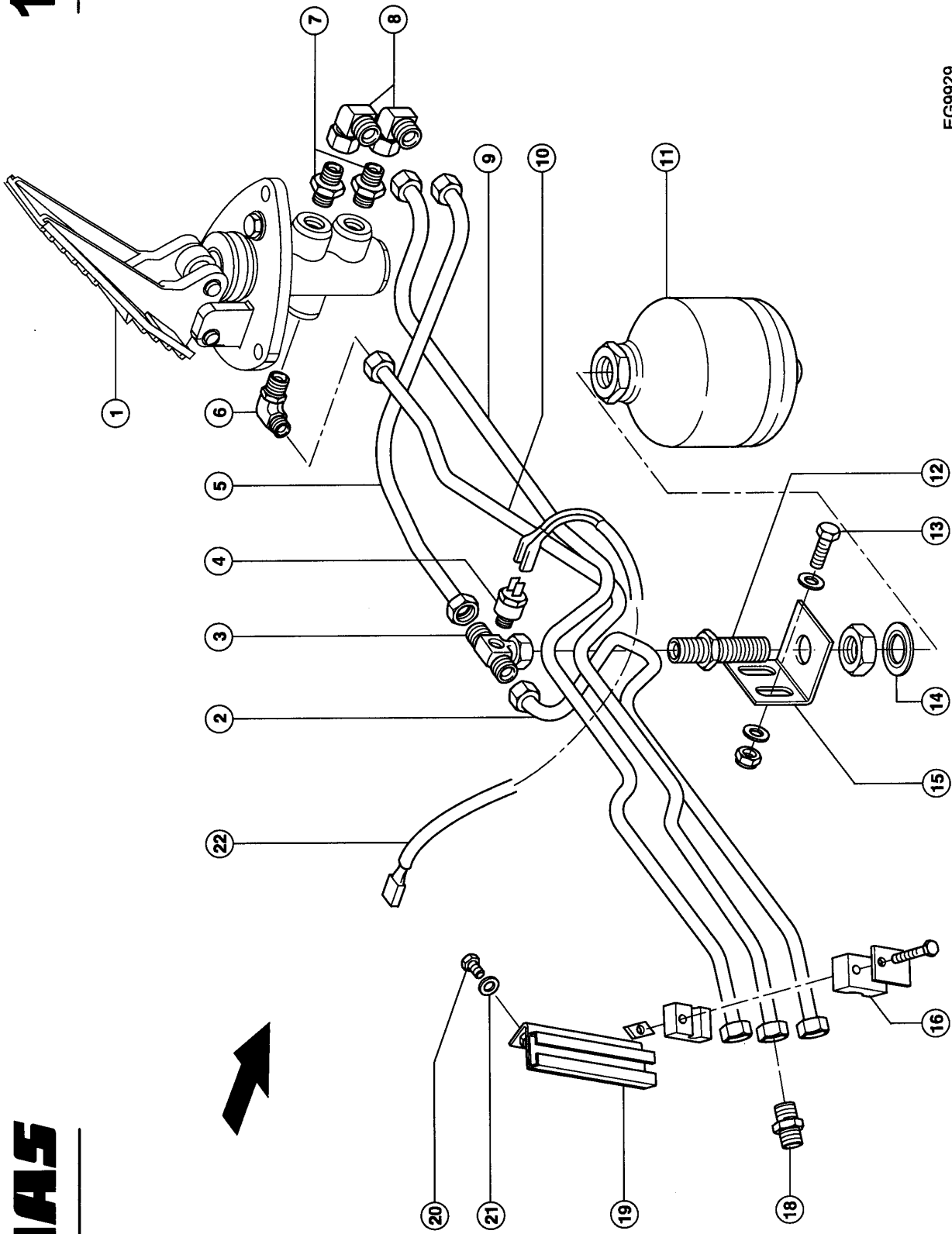

101769

BRAKE CIRCUIT 1)

Pos.	Part No.	Description	Dimension	Quantity	Conditions
1	00 0315 491 0	BRAKE VALVE		1	
2	00 0315 904 0	BRAKE PIPE		1	
3	00 0316 194 0	T-JOINT,SCREW.	SWOBT-S10 MOD. 1/8NPT	1	
4	00 0315 493 0	LOW PRESS.SWITCH	116 BAR	1	
5	00 0315 903 0	BRAKE PIPE		1	
6	00 0316 200 0	SCREW-IN FITTING	SDE-S10X9/16-18UN F-2A-TY	1	
7	00 0316 181 0	SCREW-IN FITTING	10L F-9/16UNF	2	
8	00 0316 195 0	ELBOW UNION	W.ERS.D.2386930	2	
9	00 0315 905 0	BRAKE PIPE		1	
10	00 0315 906 0	BRAKE PIPE		1	
11	00 0323 884 0	ACCUMULATOR	0,75L 210BAR	1	
12	00 0316 199 0	SUPPORT		1	
13	00 0237 442 0	HEXAGON HEAD BOLT	M8X25	2	
13	00 0236 912 2	FLAT WASHER	8 - 8,4X16X1,6	4	
13	00 0239 040 0	LOCK NUT	M8	2	
14	00 0217 004 0	SEALING WASHER	21,54X28,58X2, 47-G1/2 BS	1	
15	00 0316 335 0	SUPPORT		1	
16	00 0316 197 0	CLAMP	LD-KOR-10-PP-W1	3	
18	00 0316 368 0	SCREW-IN FITTING	S-S10	1	
19	00 0316 248 0	PLATE		1	
20	00 0233 918 0	HEXAGON HEAD BOLT	M 5X16	2	
21	00 0217 014 0	CONTACT WASHER	A 5- 5,1X12X1,1	2	
22	00 0316 392 0	WIRING LOOM		1	

1) Remarks

From Serial No. 51000423

From Serial No. 51600769

See Illustration 104 F

104C

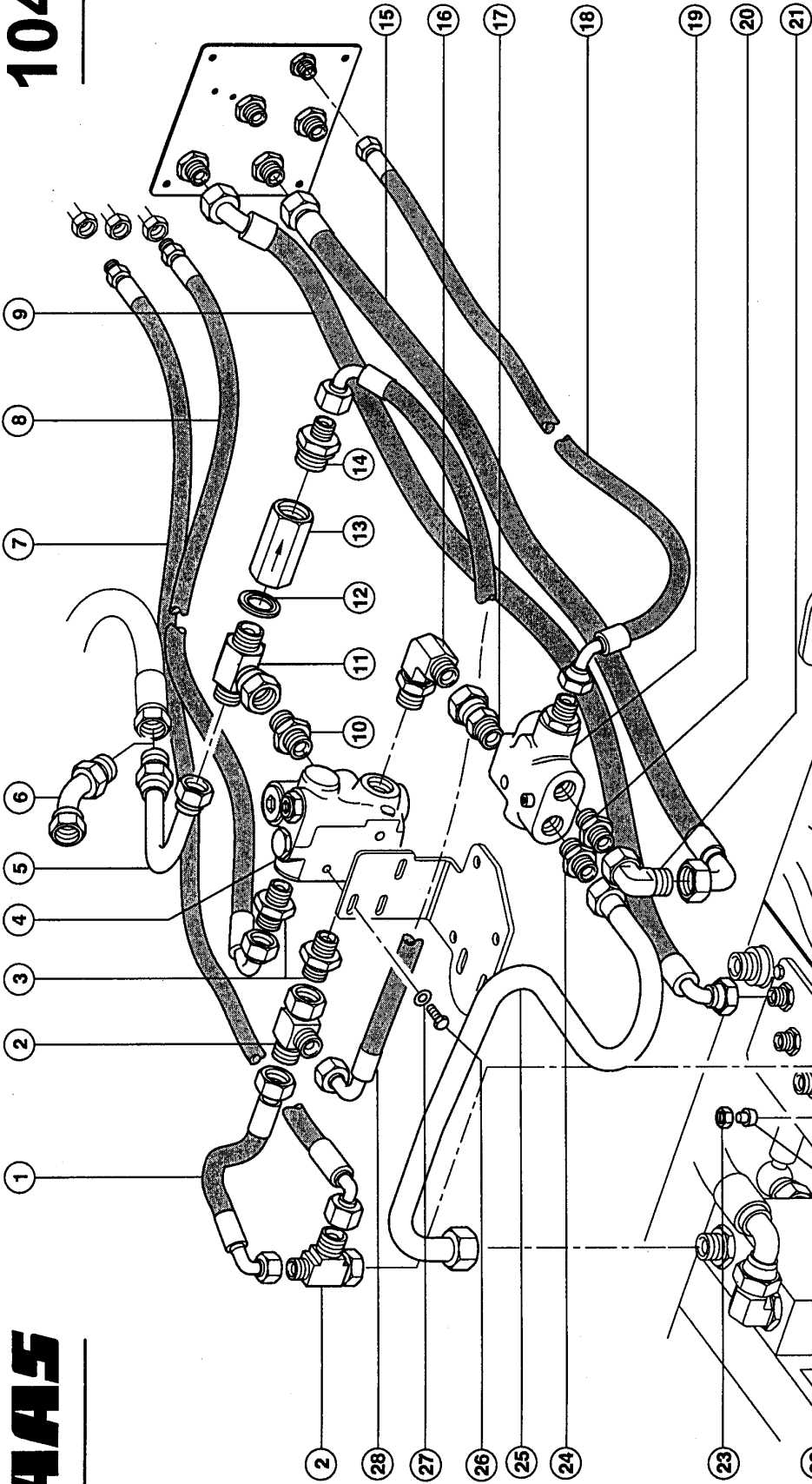

Ranger 925-975

EG9930

CLAAS

101770

Thank you so much for reading.
Please click the “Buy Now!”
button below to download the
complete manual.



After you pay.

You can download the most
perfect and complete manual in
the world immediately.

Our support email:

ebooklibonline@outlook.com