

010 COMPLETE ENGINE 1)

Pos.	Part No.	Description	Dimension	Quantity	Conditions
1	00 1921 186 0	FLANGE		1	
2	00 1921 187 0	CLAMPING HUB		1	
1)	machine no.				
			+ 0		
			+ K3400013		
			+ K3400021		
			+ K3400022		
			+ K3400023		
			+ K3400024		
			+ K3400025		
			+ K3400026		
			+ K3400027		
			+ K3400028		

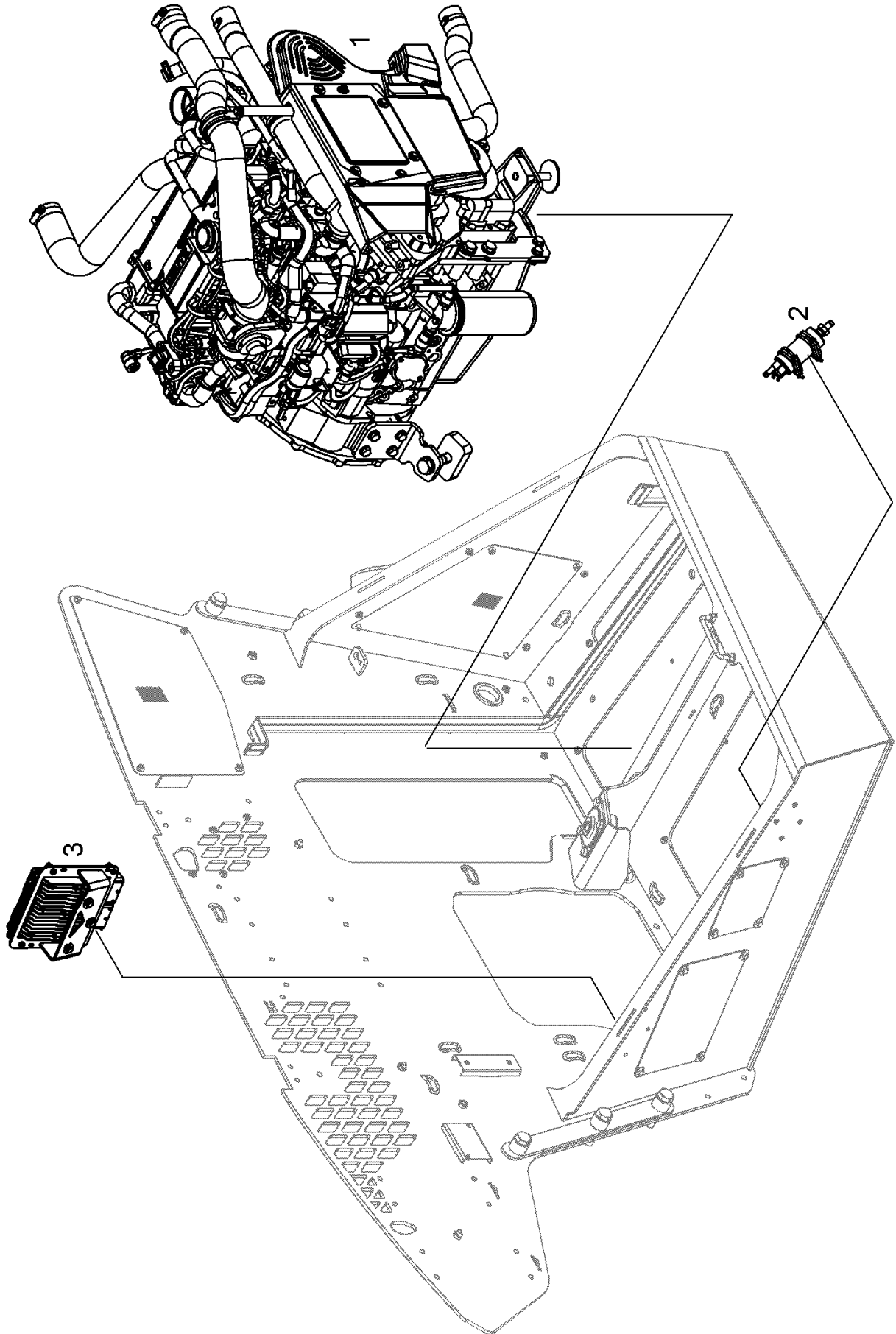

010 COMPLETE ENGINE 1)

Pos.	Part No.	Description	Dimension	Quantity	Conditions
1	ERS11	PART HAS NOT BEEN INSTALLED		1	
2	ERS05	NO LONGER AVAILABLE		1	
3	ERS05	NO LONGER AVAILABLE		1	
<hr/>					
1)	machine no.				
		+ 0			
		+ K3400013			
		+ K3400030			
		+ K3400048			
		+ K3400049			
		+ K3400063			
		+ K3400089			
		+ K3400127			
		+ K3400130			
		+ K3400605			

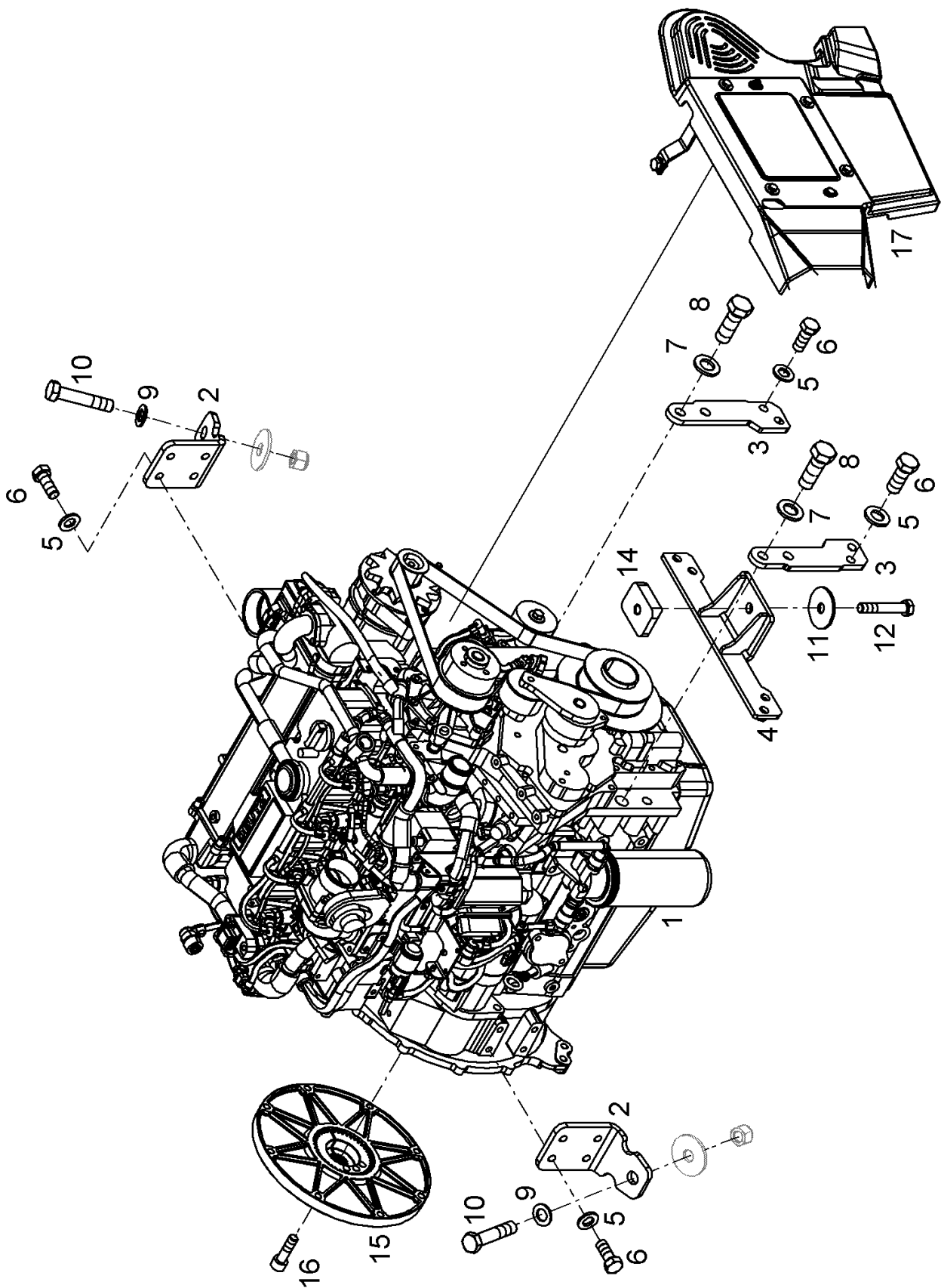

010 COMPLETE ENGINE 1)

Pos.	Part No.	Description	Dimension	Quantity	Conditions
1	00 1921 157 0	DIESEL ENGINE	TCD 3.6 100KW TIER3A	1	
2	00 1920 318 0	SUPPORTING PLATE	MOTOR	2	
3	00 1920 760 0	LAGERFUSS	ENGINE	2	
4	00 1920 287 0	BEARING PLATE	MOTOR	1	
5	00 0213 801 0	FLAT WASHER	12-13X24X2,5	12	
6	00 0233 456 0	HEXAGON HEAD BOLT	M12X30	12	
7	00 0250 059 0	FLAT WASHER	16 -17X30X3	4	
8	00 0238 662 1	HEXAGON HEAD BOLT	M16X45	4	
9	00 0214 560 0	WASHER	20 - 21X37X3	2	
10	77 0300 168 1	HEXAGON HEAD BOLT	M20X100	2	
11	00 1920 401 0	WASHER	17X69X4	1	
12	00 0214 244 0	HEXAGON HEAD BOLT	M16X90	1	
14	00 1920 343 0	THREADED PLATE	ENGINE	1	
15	00 1921 148 0	COUPLING	ENGINE	1	
16	00 1992 839 1	hexagon socket head cap screw	M10X35 ERS.D.1994520.0	8	
17	ERS08	ORDER SINGLE PARTS		1	
1)	machine no.				
			+ 0		
			+ K3400013		
			+ K3400030		
			+ K3400048		
			+ K3400049		
			+ K3400063		
			+ K3400089		
			+ K3400127		
			+ K3400130		
			+ K3400605		

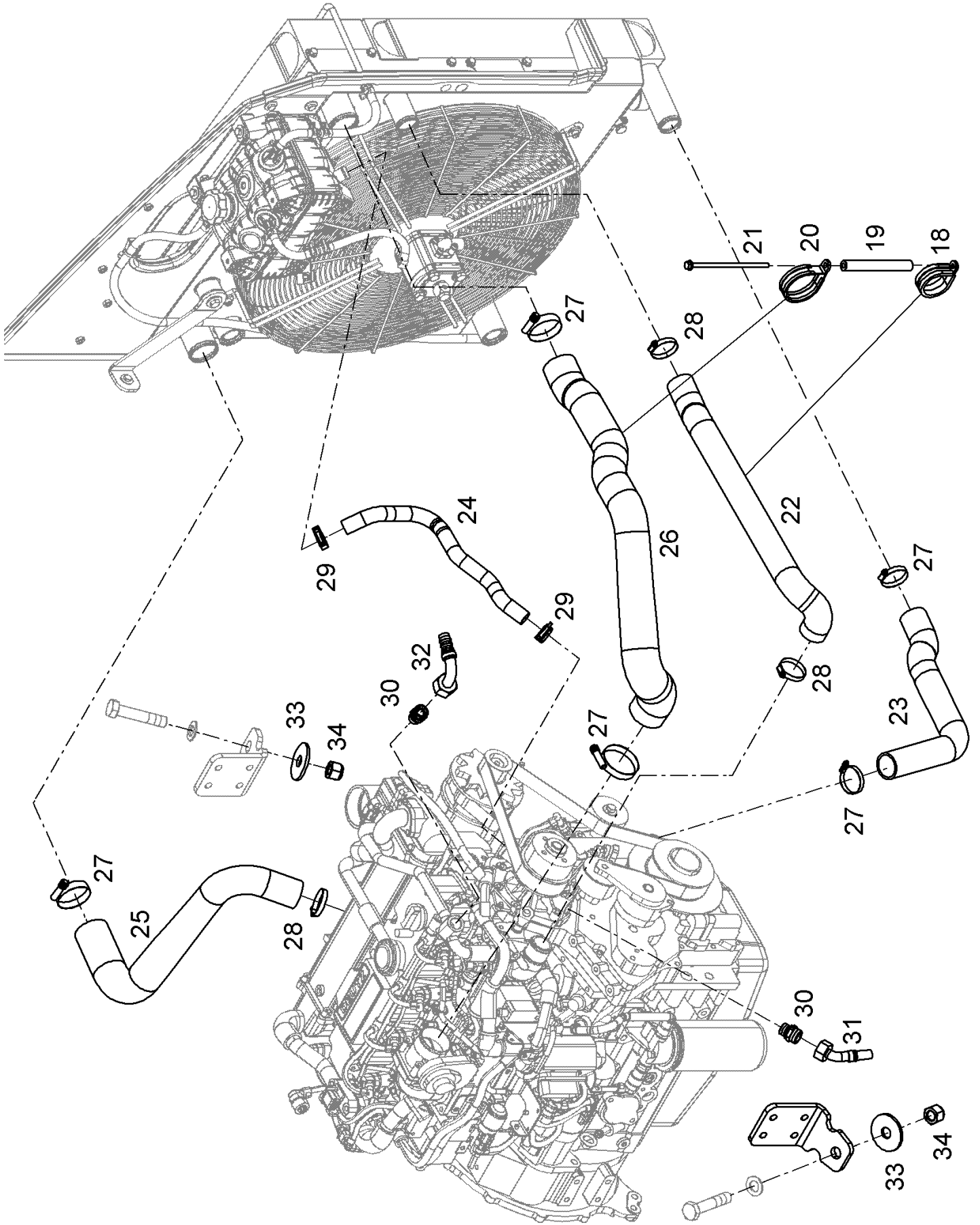

010 COMPLETE ENGINE 1)

Pos.	Part No.	Description	Dimension	Quantity	Conditions
18	00 0224 070 0	HOLDER CLAMP	D1-50X20	1	
19	00 1920 643 0	SPACER TUBE	9X19X150	1	
20	00 0224 083 0	HOLDER CLAMP	D1-67X20	1	
21	00 0224 118 0	6KT-SCHRAUBE M FL	M8X175	1	
22	00 1920 113 0	KUEHLWASSERSCHLAUCH	50 X 4	1	
23	00 1920 114 0	KUEHLWASSERSCHLAUCH	50 X 4	1	
24	00 1920 115 0	KUEHLWASSERSCHLAUCH		1	
25	00 1920 150 0	CHARGE AIR HOSE	D. 55	1	
26	00 1920 151 0	CHARGE AIR HOSE	D. 61	1	
27	00 0224 097 0	SCHELLE MIT TE-FED	40-60X14,3	5	
28	00 0224 096 0	SCHELLE MIT TE-FED	50-70X14,3	3	
29	00 1995 050 0	SPRING BAND CLAMP	A-30X12	2	
30	00 1111 841 0	STRAIGHT SCREW-IN UNION	SDS-L18XM22X1, 5-TYPE E	2	
31	00 1921 559 0	HOSE FITTING	SWE45 18X16(M26X1, 5)45 2	1	
32	00 1301 465 0	HOSE FITTING		1	
33	00 1921 453 0	WASHER	21X70X5	2	
34	00 0224 398 0	HEX. NUT WITH CLAMP. PART	M20	2	

1)	machine no.	+ 0
		+ K3400013
		+ K3400030
		+ K3400048
		+ K3400049
		+ K3400063
		+ K3400089
		+ K3400127
		+ K3400130
		+ K3400605

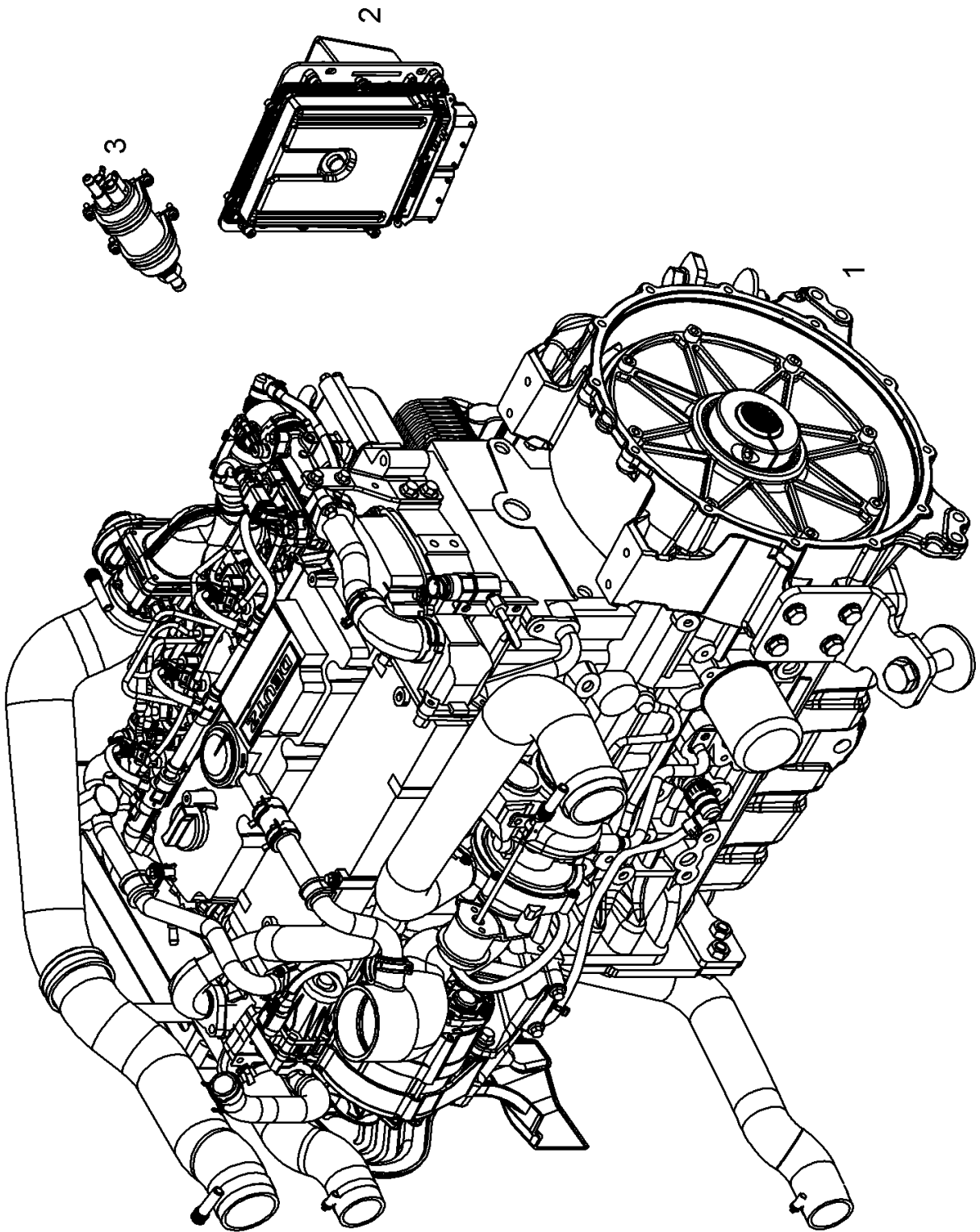

010 COMPLETE ENGINE 1)

Pos.	Part No.	Description	Dimension	Quantity	Conditions
1	ERS08	ORDER SINGLE PARTS		1	
2	ERS05	NO LONGER AVAILABLE		1	
3	ERS05	NO LONGER AVAILABLE		1	
<hr/>					
1)	machine no.				
					+ 0
					+ K3400600
					+ K3400601
					+ K3400602
					+ K3400603
					+ K3400604
					+ K3400607
					+ K3400608
					+ K3400609
					+ K3400610

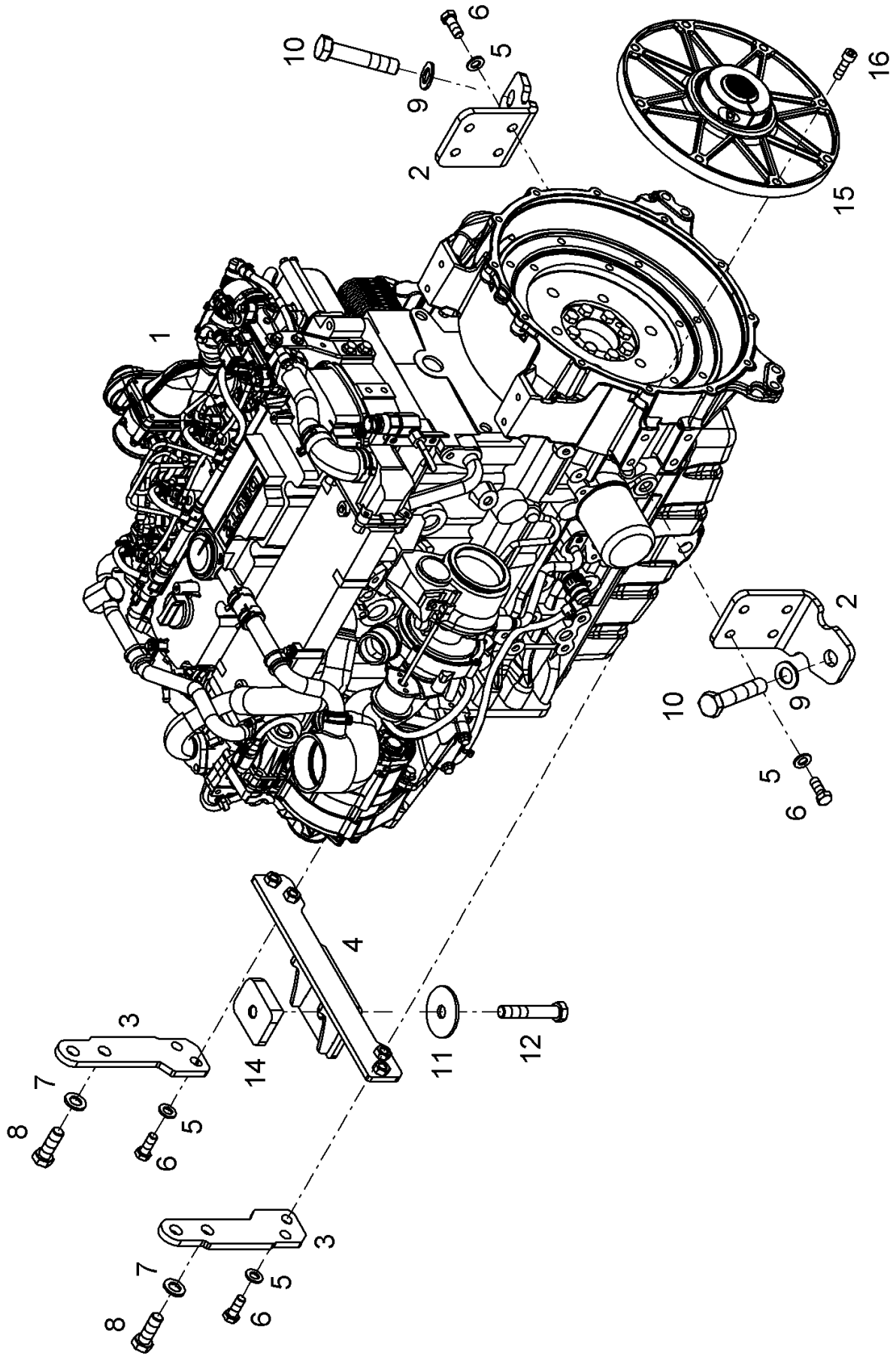

010 COMPLETE ENGINE 1)

Pos.	Part No.	Description	Dimension	Quantity	Conditions
1	00 1922 462 0	DIESEL ENGINE	TCD 3.6 100KW STAGE 1 V	1	
2	00 1920 318 0	SUPPORTING PLATE	MOTOR	2	
3	00 1920 760 0	LAGERFUSS	ENGINE	2	
4	00 1920 287 0	BEARING PLATE	MOTOR	1	
5	00 0213 801 0	FLAT WASHER	12-13X24X2,5	12	
6	00 0233 456 0	HEXAGON HEAD BOLT	M12X30	12	
7	00 0250 059 0	FLAT WASHER	16 -17X30X3	4	
8	00 0238 662 1	HEXAGON HEAD BOLT	M16X45	4	
9	00 0214 560 0	WASHER	20 - 21X37X3	2	
10	77 0300 168 1	HEXAGON HEAD BOLT	M20X100	2	
11	00 1920 401 0	WASHER	17X69X4	1	
12	00 0214 244 0	HEXAGON HEAD BOLT	M16X90	1	
14	00 1920 343 0	THREADED PLATE	ENGINE	1	
15	00 1921 148 0	COUPLING	ENGINE	1	
16	00 1992 839 1	hexagon socket head cap screw	M10X35 ERS.D.1994520.0	8	

1)	machine no.	+ 0
		+ K3400600
		+ K3400601
		+ K3400602
		+ K3400603
		+ K3400604
		+ K3400607
		+ K3400608
		+ K3400609
		+ K3400610

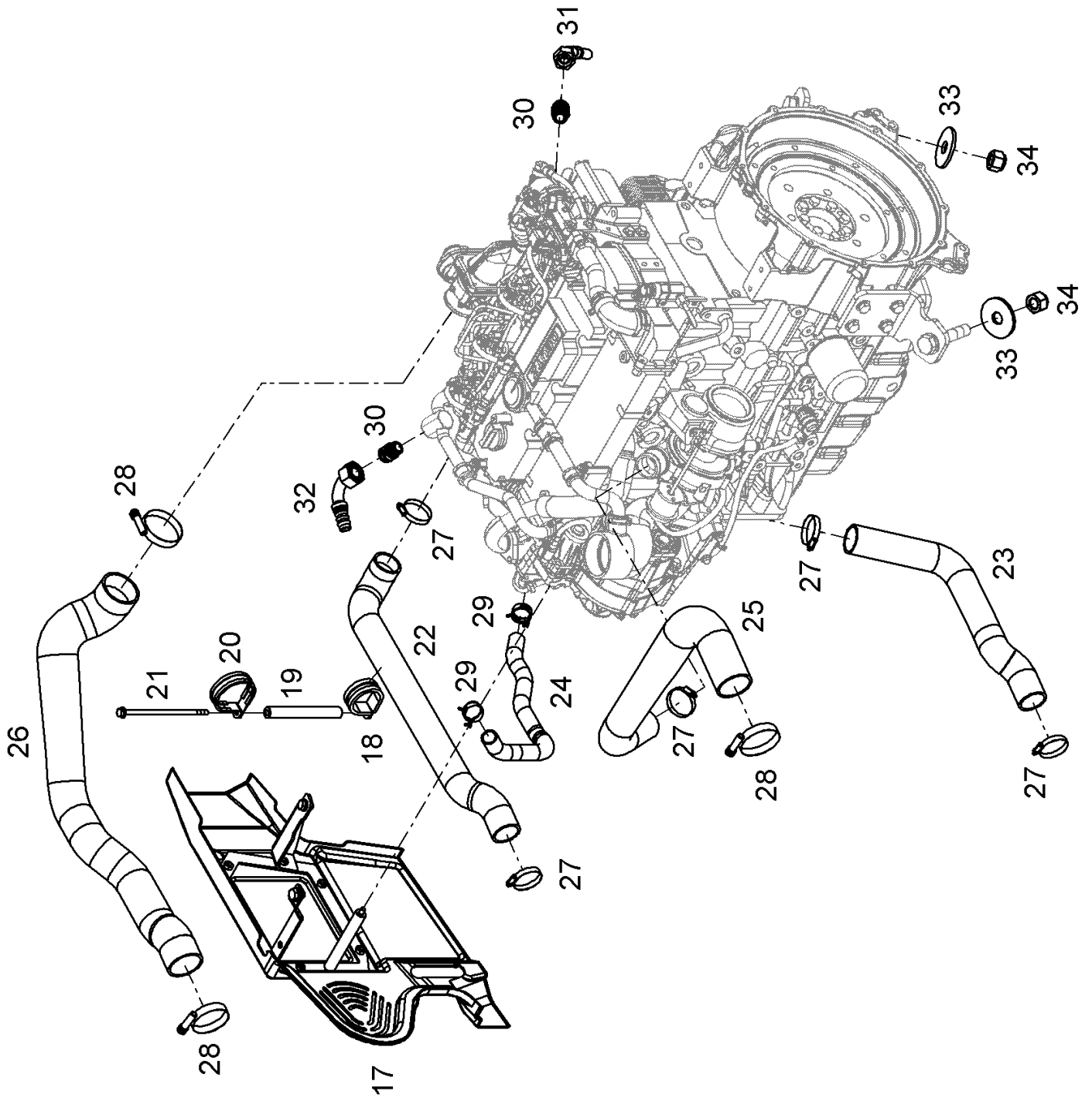

010 COMPLETE ENGINE 1)

Pos.	Part No.	Description	Dimension	Quantity	Conditions
17	ERS08	ORDER SINGLE PARTS		1	
18	00 0224 070 0	HOLDER CLAMP	D1-50X20	1	
19	00 1920 643 0	SPACER TUBE	9X19X150	1	
20	00 0224 083 0	HOLDER CLAMP	D1-67X20	1	
21	00 0224 118 0	6KT-SCHRAUBE M FL	M8X175	1	
22	00 1920 113 0	KUEHLWASSERSCHLAUCH	50 X 4	1	
23	00 1920 114 0	KUEHLWASSERSCHLAUCH	50 X 4	1	
24	00 1920 115 0	KUEHLWASSERSCHLAUCH		1	
25	00 1920 150 0	CHARGE AIR HOSE	D. 55	1	
26	00 1920 151 0	CHARGE AIR HOSE	D. 61	1	
27	00 0224 097 0	SCHELLE MIT TE-FED	40-60X14,3	5	
28	00 0224 096 0	SCHELLE MIT TE-FED	50-70X14,3	3	
29	00 1995 050 0	SPRING BAND CLAMP	A-30X12	2	
30	00 1111 841 0	STRAIGHT SCREW-IN UNION	SDS-L18XM22X1, 5-TYPE E	2	
31	00 1921 559 0	HOSE FITTING	SWE45 18X16(M26X1, 5)45 2	1	
32	00 1301 465 0	HOSE FITTING		1	
33	00 1921 453 0	WASHER	21X70X5	2	
34	00 0224 398 0	HEX. NUT WITH CLAMP. PART	M20	2	

1)	machine no.	+ 0
		+ K3400600
		+ K3400601
		+ K3400602
		+ K3400603
		+ K3400604
		+ K3400607
		+ K3400608
		+ K3400609
		+ K3400610

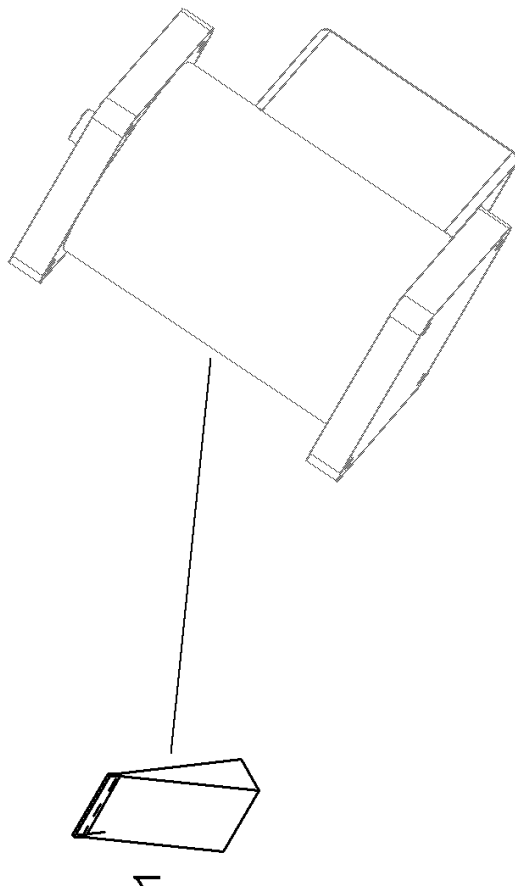

Thank you so much for reading.
Please click the “Buy Now!”
button below to download the
complete manual.



After you pay.

You can download the most
perfect and complete manual in
the world immediately.

Our support email:

ebooklibonline@outlook.com