

100 ENGINE SUSPENSION

Pos.	Part No.	Description	Dimension	Quantity	Conditions
1	00 1304 572 0	ENGINE	TCD 3.6 L4 90 KW 2300 MI	1	
2	00 1304 575 0	ENGINE	TCD 3.6 L4 90 KW 2300 MI	1	1)
3	00 1305 336 0	FLANGE	F. KUPPLUNG	1	
4	00 0235 495 1	SOCKET HEAD SCREW	M10X 25	12	
5	00 1305 364 0	CLUTCH		1	
6	60 0502 645 4	SCREW	M08X20	6	
7	00 1304 373 0	BEARING	30/31	2	
8	00 1304 374 0	BEARING	30/31	2	
9	00 0237 383 0	HEXAGON HEAD BOLT	M10X25	16	
10	00 0479 671 0	ADJUSTING DISC	14X60X1,0	1	
11	00 0479 670 0	ADJUSTING DISC	14X60X0,5	1	
12	00 0479 672 0	ADJUSTING DISC	14X60X1,5	1	
13	00 1304 702 0	BEARING	KPLT.	2	
14	00 1304 683 0	BEARING	KPLT.	1	
15	00 1304 682 0	BEARING	KPLT.	1	
16	00 0237 761 1	SOCKET HEAD SCREW	M12X 30	12	
17	00 0237 572 0	HEXAGON HEAD BOLT	M12X35	4	
1)	Remarks		DPF		

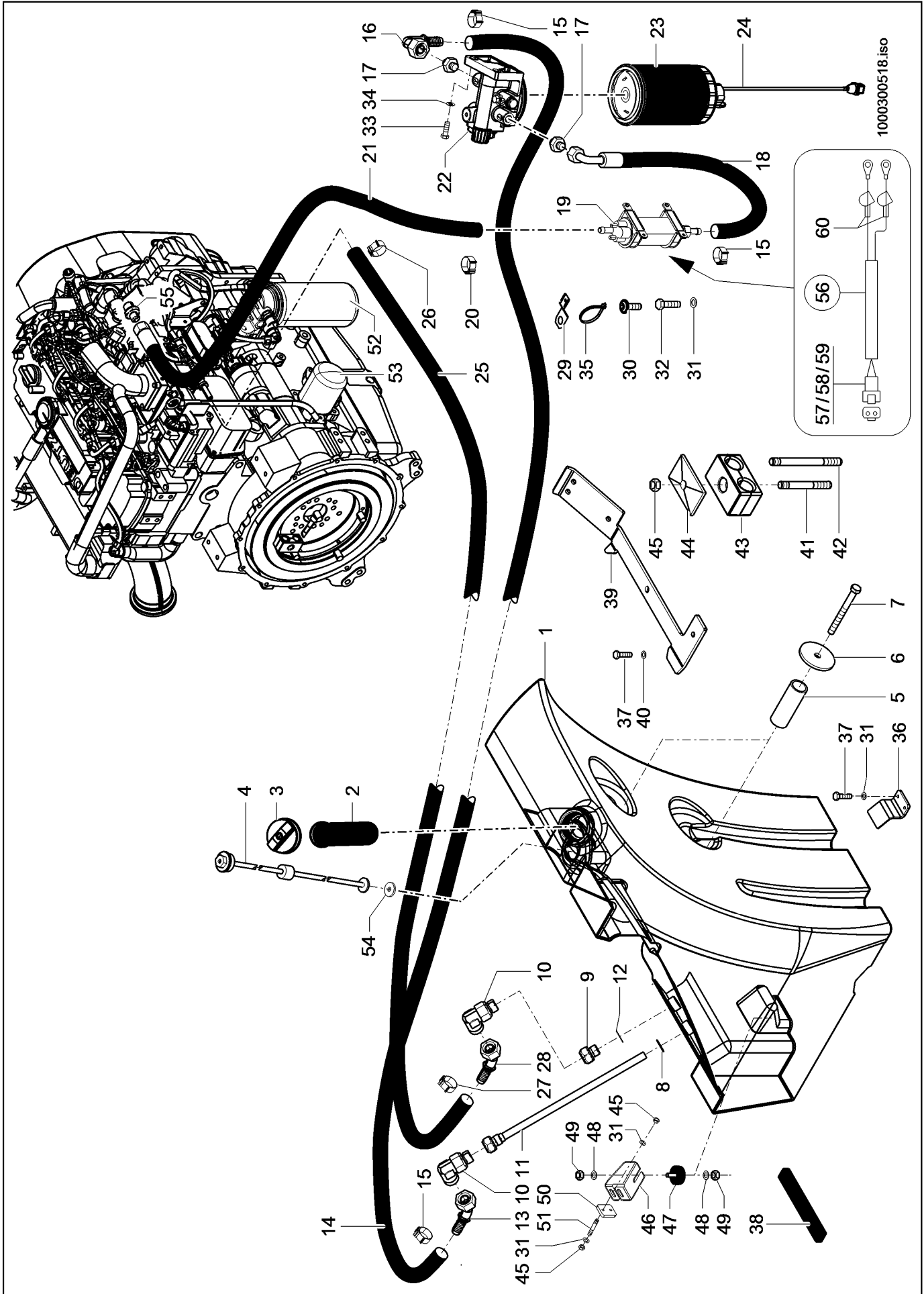

100 FUEL TANK

Pos.	Part No.	Description	Dimension	Quantity	Conditions
1	00 1305 608 0	FUEL TANK		1	
2	00 1302 051 0	FILL IN STRAINER		1	
3	00 1305 708 0	LOCKING COVER	KRAFTSTOFFTANK	1	
4	00 1306 222 0	LEVEL TRANSMITTER	835 MM LG.	1	
5	00 1300 436 0	SPACER TUBE		2	
6	00 1301 418 0	WASHER		2	
7	00 0215 898 0	HEXAGON HEAD BOLT	M16X160	2	
8	00 0217 982 0	SEALING RING	A 22X29X1,5	1	
9	00 1306 214 0	REDUCING ADAPTER	A-E-M22X1,5 - I-B-M18X1,	1	
10	00 1301 578 0	SCREW-IN FITTING	SDE-L12XM18X1, 5-TYPE H	2	
11	00 1305 293 0	CONNECTOR	I-B-M18X1,5	1	
12	00 0217 982 0	SEALING RING	A 22X29X1,5	1	
13	00 1306 340 0	HOSE FITTING	SWE45 L12 X 12,5	1	
14	00 1306 776 0	FUEL HOSE	12X3,5X5000	1	
15	00 0223 019 0	CLAMP	COBRA 19/8	3	
16	00 0796 220 0	CONNECTION	DN12-N90L15(M22X1,5) 5)ERS.	1	
17	00 1301 591 0	SCREW-IN FITTING	SDS-L15XM16X1, 5-TYPE E	3	
18	00 1305 431 0	HOSE PIPE		1	
19	00 1994 852 0	DELIVERY PUMP	12 V	1	
20	00 0223 018 0	CLAMP	COBRA 15/8	1	
21	00 1306 075 0	HOSE PIPE		1	
22	00 1995 104 0	FUEL PRE-FILTER		1	
23	00 1995 121 0	FILTER CARTRIDGE		1	
24	00 1993 118 0	SENSOR CABLE		1	
25	00 1305 496 0	FUEL HOSE	10X3X2,50 M	1	
26	00 1302 315 0	CLAMP	COBRA 16/8	1	
27	00 0223 377 0	CLAMP	COBRA 14/8	1	
28	00 1306 923 0	HOSE FITTING	SWE45 L12 X 10	1	
29	00 1302 326 0	CLIP	F. DEUTSHSTECKER DT2 - SE	1	
30	00 1301 477 0	PANHEAD SCREW W. IN HEX.	M5X16	8	
31	00 0237 816 0	WASHER	8-8,4X24X2	6	
32	00 0237 439 0	HEXAGON HEAD BOLT	M8X16	2	
33	00 0237 383 0	HEXAGON HEAD BOLT	M10X25	2	
34	00 0215 683 0	WASHER	10,5	2	
35	00 1301 792 0	CABLE TIE	4,6 X 300 LAMELLENFUSS +	1	
36	00 1305 925 0	SUPPORT		1	
37	00 0236 200 0	HEXAGON HEAD BOLT	M8X20	3	
38	00 1306 352 0	SEAL BAND		3	
39	00 1306 367 0	SUPPORT	MOTORKABEL	1	
40	00 0215 682 0	WASHER	8,4	1	
41	00 1301 537 0	STUD BOLT	M08X45	1	
42	00 0147 145 0	STUD BOLT	M 8 X 65	3	
43	00 1302 907 0	CLAMP	Z KP-2-R-18-15-PP	4	
44	00 0216 994 0	COVER PLATE	Z DP-2-W1	4	
45	00 0238 132 0	LOCK NUT	M8	6	
46	00 1304 610 0	SUPPORT		1	
47	00 1304 375 0	BUFFER BUMPER	D 50X18-M10X38	1	
48	00 0237 592 0	WASHER	D10,5X30X2,5	2	
49	00 0236 171 0	HEXAGONAL NUT	M10	2	
50	00 1304 795 0	THREADED PLATE		1	

100 FUEL TANK

Pos.	Part No.	Description	Dimension	Quantity	Conditions
51	00 0215 437 0	STUD BOLT	M 8X 25	2	
52	00 1995 273 0	FUEL FILTER		1	
53	00 1302 948 0	OIL FILTER		1	
54	#NV			1	
55	00 0216 097 0	STRAIGHT MALE CONNECTOR	SDS-L12XM16X1, 5-TYPE E	1	
56	00 1306 081 0	CABLE CPL.	ANSCHLUSS VORFOERDERPUMP	1	
57	00 0326 892 0	PIN HOUSING	2-POLIG	1	
58	00 1301 785 0	PLUG	1,0 - 2,0	2	
59	00 1301 763 0	V-SHAPED ELEMENT	2-POLIG	1	
60	00 0132 358 0	GUARD CAP	D12- D6- LG32	2	

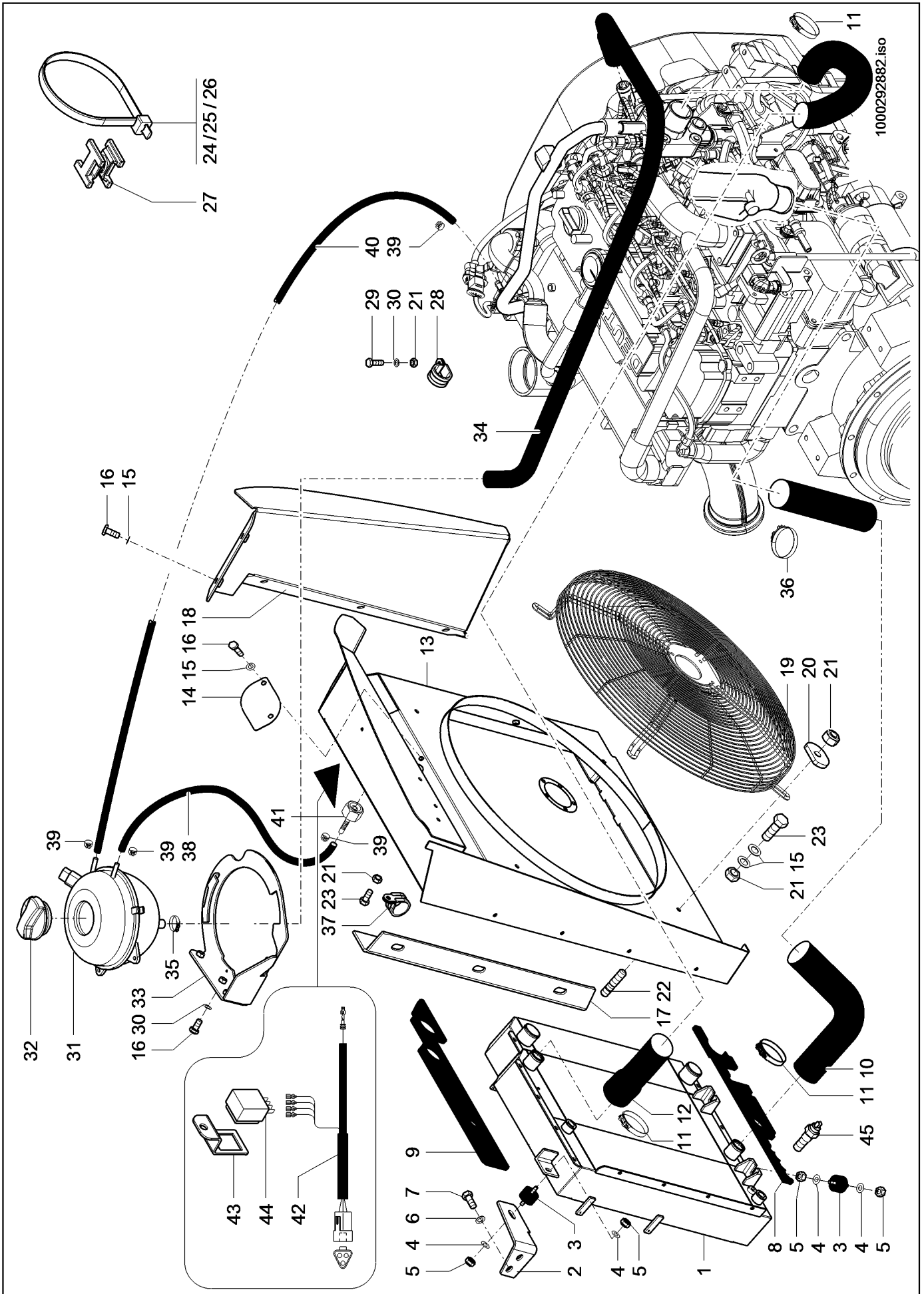

140 ENGINE COOLER 1)

Pos.	Part No.	Description	Dimension	Quantity	Conditions
1	00 1304 703 1	RADIATOR		1	
2	00 1303 169 0	SUPPORT		1	
3	00 1304 412 0	BEARING	D 50X30 M 10X25	3	
4	00 0237 592 0	WASHER	D10,5X30X2,5	6	
5	00 0238 316 0	LOCK NUT	M10	6	
6	00 0237 592 0	WASHER	D10,5X30X2,5	2	
7	00 0237 570 0	HEXAGON HEAD BOLT	M10X16	2	
8	00 1304 825 0	GASKET		1	
9	00 1304 826 0	GASKET		1	
10	00 1304 710 0	PRESHAPED TUBE		1	
11	00 0217 447 0	HOSE CLAMP	B1-58X15	4	
12	00 1304 711 0	PRESHAPED TUBE		1	
13	00 1304 780 0	DIVIDER PLATE		1	
14	00 1304 699 0	PLATE		1	
15	00 0215 682 0	WASHER	8,4	10	
16	00 0237 439 0	HEXAGON HEAD BOLT	M8X16	10	
17	00 1304 858 0	ANGLE		1	
18	00 1306 424 0	GUIDE PLATE	KÜHLER	1	
19	00 1304 713 0	GUARD SCREEN		1	
20	00 1302 871 0	WASHER	N.Z.	4	
21	00 0238 132 0	LOCK NUT	M8	8	
22	00 0215 437 0	STUD BOLT	M 8X 25	4	
23	00 0237 442 0	HEXAGON HEAD BOLT	M8X25	1	
24	00 0689 560 0	CABLE TIE	MIN.510 X 12,7 X 1,9	1	
25	00 1301 791 0	CABLE TIE	3,6X142	1	
26	00 1301 790 0	CABLE TIE	4,6X200	2	
27	00 1305 220 0	CONNECTION	DSWS4 26,3X20,3X18,01		
28	00 0211 709 0	HOLDER CLAMP	D1-50X25	1	
29	00 0236 200 0	HEXAGON HEAD BOLT	M8X20	1	
30	00 0237 816 0	WASHER	8-8,4X24X2	4	
31	00 1300 321 0	COMPENSATION RESERVOIR		1	
32	00 1300 075 0	VALVE COVER	AUSGLEICHSBEHAELT ER	1	
33	00 1304 606 0	SUPPORT	KPLT.	1	
34	00 1305 111 0	PRESHAPED TUBE		1	
35	00 1302 911 0	HOSE CLAMP	B1-30X15	1	
36	00 0215 408 2	HOSE CLAMP	A-16-27X9	1	
37	00 0364 814 0	CLAMP	D-25X20-10,5 ERS.D.03648	1	
38	00 1301 462 0	HOSE	8X3 - 2A NBR/CR	1	
39	00 1301 444 0	CLAMP	COBRA 12/8 SCHWARZ	4	
40	00 1301 462 0	HOSE	8X3 - 2A NBR/CR	0	
41	00 0738 772 0	CONNECTION	DN08 - N L10 (M16X1, 1 5)	1	
42	00 1305 114 0	CABLE HARNESS	KPLT.	1	
43	00 1305 115 0	SUPPORTING PLATE		1	
44	00 1305 215 0	AMPLIFIER		1	
45	00 1300 175 0	TEMPERAT.FEELER	40 - 120°C - M14X1,5	1	

1) machine no.

+ up to 415030005

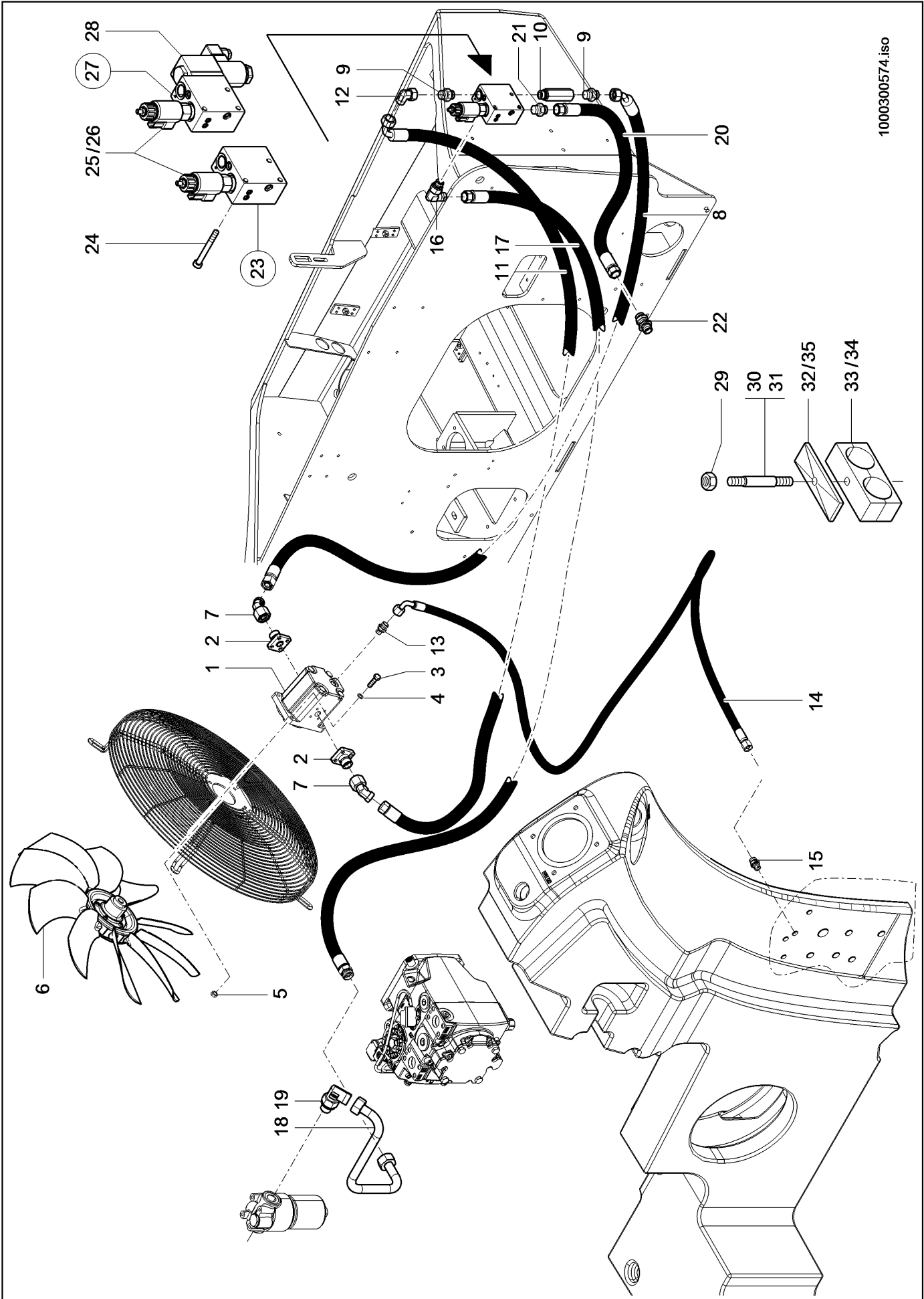

1000300574.iso

140 ENGINE COOLER

Pos.	Part No.	Description	Dimension	Quantity	Conditions
1	00 1300 598 1	HYDRAULIC MOTOR	14 CCM BIDIRECTIONAL	1	
2	00 0808 783 0	ANGLE FLANGE	WFS-L15-LK35	2	
3	00 0237 342 0	HEXAGON HEAD BOLT	M 8X30	4	
4	00 0215 682 0	WASHER	8,4	4	
5	00 0238 132 0	LOCK NUT	M8	4	
6	00 1304 607 0	FAN WHEEL	600 MM	2	
7	00 0217 166 0	ELBOW UNION		2	
8	00 1305 461 0	HOSE PIPE		1	
9	00 0249 780 0	SCREW-IN FITTING	SDS-L18XG1/2A-TYPE E	2	
10	00 1305 541 0	REDUCING ADAPTER	G1/2 - G1/2 80 MM LG.	1	
11	00 1305 462 0	HOSE PIPE		1	
12	00 0249 837 0	ANGLE UNION	SWOE-L18	1	
13	00 0249 774 0	SCREW-IN FITTING	SDS-L10XG1/4A-TYPE E	1	
14	00 1305 862 0	HOSE PIPE		1	
15	00 0250 004 0	SCREW-IN FITTING	SDS-L10XM14X1, 5-TYPE E	1	
16	00 1301 577 0	SCREW-IN FITTING	SDE-L18XG1/2A-TYPE H	1	
17	00 1305 463 0	HOSE PIPE		1	
18	00 1304 820 0	PIPE	KPLT.	1	
19	00 1301 603 0	SCREW-IN FITTING	SDE-L18XM22X1, 5-TYPE H	1	
20	00 1305 446 0	HOSE PIPE		1	
21	00 0215 485 0	STRAIGHT CONNECTOR	L18	1	
22	00 0249 780 0	SCREW-IN FITTING	SDS-L18XG1/2A-TYPE E	1	
23	00 1304 390 0	VALVE		1	
24	00 1992 832 0	SOCKET HEAD SCREW	M8X60	3	
25	00 1304 428 0	SOLENOID VALVE		2	
26	00 1307 412 0	SOLENOID	M19P-12D-1.1A-DE	2	
27	00 1304 389 0	REVERSING VALVE		1	
28	00 1304 429 0	SOLENOID		1	
29	00 0211 113 0	LOCK NUT	M6	1	
30	00 1301 536 0	STUD BOLT	M6X55	1	
31	00 0219 932 0	STUD BOLT	M 6X 50	1	
32	00 1300 066 0	COVER PLATE	L DP-3-W1	1	
33	00 0471 222 0	CLAMP	L KP-3-G-23-PP	1	
34	00 1301 432 0	CLAMP	L KP - 4- R - 28 - PP	1	
35	00 1300 067 0	COVER PLATE	L DP-4-W1	1	

140 ENGINE COOLER 1)

Pos.	Part No.	Description	Dimension	Quantity	Conditions
1	00 1306 407 0	RADIATOR	20 / 30 KMH	1	
2	00 1303 169 0	SUPPORT		1	
3	00 1304 412 0	BEARING	D 50X30 M 10X25	3	
4	00 0237 592 0	WASHER	D10,5X30X2,5	8	
5	00 0238 316 0	LOCK NUT	M10	6	
6	00 0237 570 0	HEXAGON HEAD BOLT	M10X16	2	
7	00 1304 825 0	GASKET		1	
8	00 1306 418 0	GASKET	KÜHLER	1	
9	00 1304 711 0	PRESHAPED TUBE		1	
10	00 0217 447 0	HOSE CLAMP	B1-58X15	4	
11	00 1304 710 0	PRESHAPED TUBE		1	
12	00 1306 414 0	AIR INTAKE HSG.	KÜHLER	1	
13	00 1306 415 0	GUIDE PLATE	KÜHLER	1	
14	00 1304 858 0	ANGLE		1	
15	00 0215 437 0	STUD BOLT	M 8X 25	4	
16	00 1306 413 0	PRESHAPED TUBE	KÜHLUNG	1	
17	00 0223 020 0	HOSE CLAMP	B1 X 28 X 15	1	
18	00 0215 408 2	HOSE CLAMP	A-16-27X9	1	
19	00 0237 439 0	HEXAGON HEAD BOLT	M8X16	12	
20	00 0215 682 0	WASHER	8,4	12	
21	00 1304 699 0	PLATE		1	
22	00 1302 871 0	WASHER	N.Z.	4	
23	00 0238 132 0	LOCK NUT	M8	10	
24	00 0215 083 0	HOLDER CLAMP	D1-30X25	1	
25	00 1301 444 0	CLAMP	COBRA 12/8	5	
26	00 0478 991 0	EDGE PROTECTOR	SCHWARZ 9,5X6,5;1-2MM - 100M0 BUN		2)
27	00 1305 220 0	CONNECTION	DSWS4 26,3X20,3X18,01		
28	00 1301 791 0	CABLE TIE	3,6X142	1	
29	00 1301 790 0	CABLE TIE	4,6X200	2	
30	00 1302 326 0	CLIP	F. DEUTSHSTECKER DT1 - SE		
31	00 1306 955 0	SENSOR		1	
32	00 1301 462 0	HOSE	8X3 - 2A NBR/CR	1	3)
33	00 1301 462 0	HOSE	8X3 - 2A NBR/CR	0	4)
34	00 0738 772 0	CONNECTION	DN08 - N L10 (M16X1, 1 5)		
35	00 1301 571 0	UNION	SDS-L10XM12X1, 5-TYPE E	1	
36	00 1301 462 0	HOSE	8X3 - 2A NBR/CR	2	5)
37	00 1303 130 0	GROMMET		1	
38	00 1304 713 0	GUARD SCREEN		1	
39	00 1300 175 0	TEMPERAT.FEELER	40 - 120°C - M14X1,5	1	
40	00 1307 054 0	LOCKING COVER	F. ÖL-WASSER-KÜHLER 1304	1	
41	00 0656 014 1	SCREW PLUG	M14X1,5	1	

1) machine no. + from 415030006

2) Remarks 480 mm long

3) Remarks 800mm long

4) Remarks 470 mm

5) Remarks 17+22 cm³

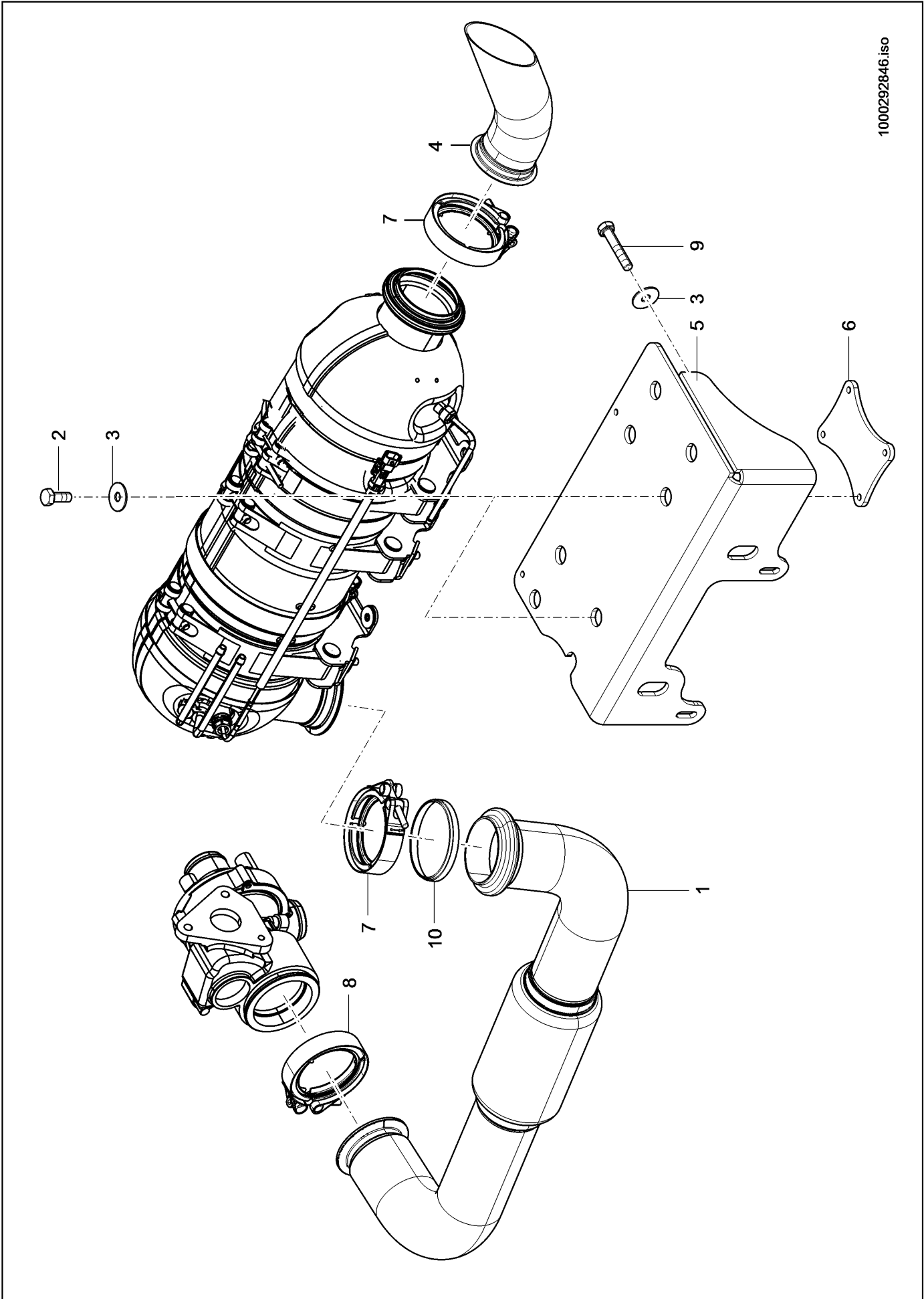

1000292846.iso

Thank you so much for reading.
Please click the “Buy Now!”
button below to download the
complete manual.



After you pay.

You can download the most
perfect and complete manual in
the world immediately.

Our support email:

ebooklibonline@outlook.com