

100 ENGINE SUSPENSION

Pos.	Part No.	Description	Dimension	Quantity	Conditions
1	00 1307 198 0	DIESEL ENGINE	TCD 4.1 S4 115 KW 2300 M	1	
2	00 1307 491 0	DIESEL ENGINE	TCD 4.1 S4 115 KW 2300 M	1	1)
3	00 1304 373 0	BEARING	30/31	2	
4	00 1307 297 0	BEARING		1	
5	00 0236 230 0	HEXAGON HEAD BOLT	M16X35	4	
6	00 0237 383 0	HEXAGON HEAD BOLT	M10X25	16	
7	00 0215 683 0	WASHER	10,5	16	
8	00 0237 572 0	HEXAGON HEAD BOLT	M12X35	4	
9	00 1301 406 0	WASHER	13 ST A2C	4	
10	00 1307 597 0	MOTORLAGERUNG KPL.	115 KW	1	
11	00 0237 761 1	SOCKET HEAD SCREW	M12X 30	8	
12	00 1304 775 0	BEARING	KPLT.	2	
13	00 1304 374 0	BEARING	30/31	2	
14	00 1305 311 0	FLANGE	F. KUPPLUNG	1	
15	00 1304 397 0	CLUTCH		1	
16	50 0300 903 6	HEX. SOCKET CHEESE-HEAD SCREW	M10X20	8	
17	00 0223 022 0	STUD BOLT	M10X20	2	
18	00 0236 171 0	HEXAGONAL NUT	M10	2	
19	00 0479 671 0	ADJUSTING DISC	14X60X1,0	1	2)
20	00 0479 670 0	ADJUSTING DISC	14X60X0,5	1	3)
21	00 0479 672 0	ADJUSTING DISC	14X60X1,5	1	4)
22	00 0235 495 1	SOCKET HEAD SCREW	M10X 25	10	
23	00 1307 199 0	DIESEL ENGINE	TCD 4.1 S4 115 KW 2300 M	1	
24	00 0235 585 0	HEXAGON HEAD BOLT	M16X45	2	

1)	Remarks	Compressor
2)	Remarks	1.0 mm
3)	Remarks	0.5 mm
4)	Remarks	1.5 mm

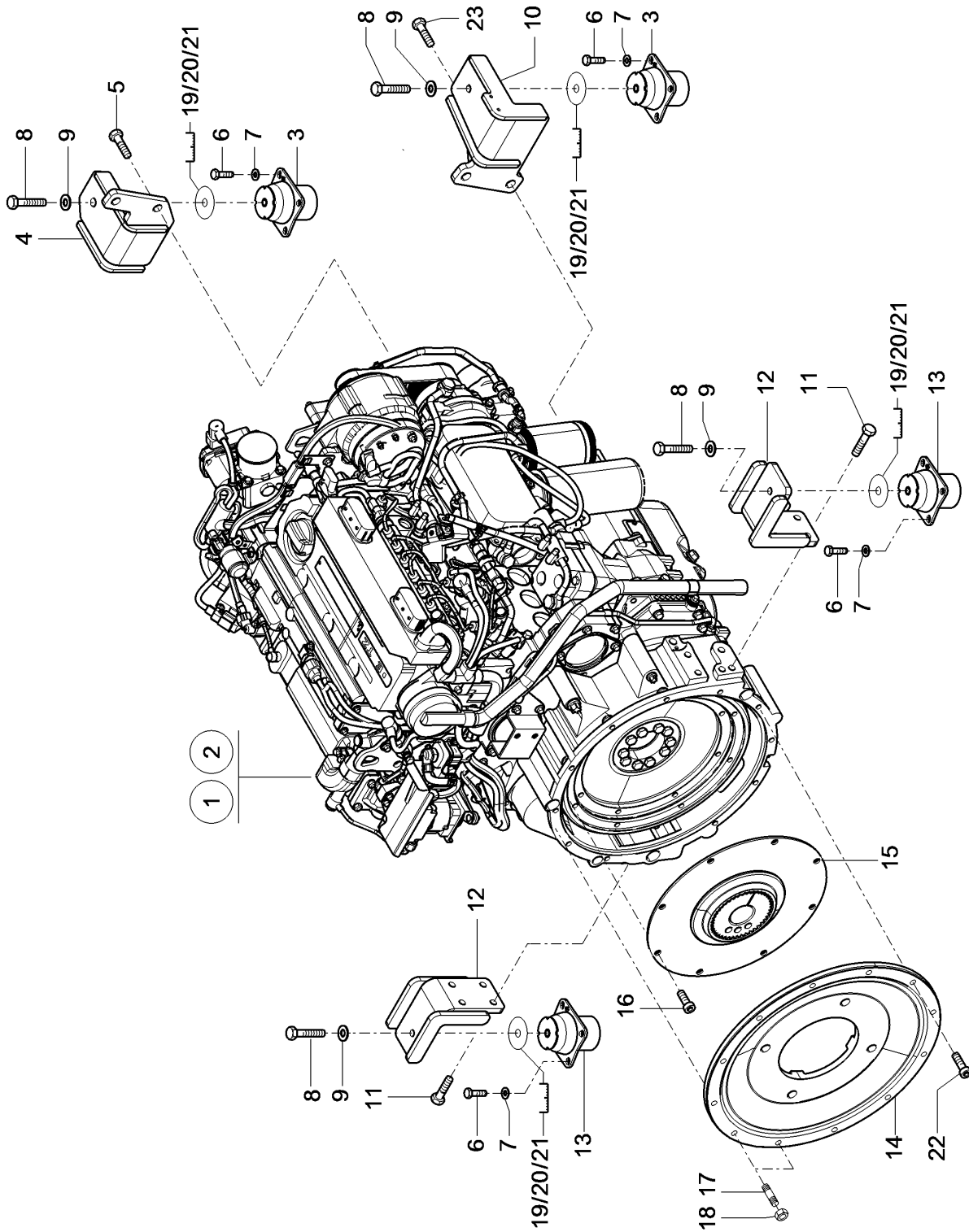

100 ENGINE SUSPENSION 1)

Pos.	Part No.	Description	Dimension	Quantity	Conditions
1	00 1307 199 0	DIESEL ENGINE	TCD 4.1 S4 115 KW 2300 M	1	
3	00 1304 373 0	BEARING	30/31	2	
4	00 1307 297 0	BEARING		1	
5	00 0236 230 0	HEXAGON HEAD BOLT	M16X35	4	
6	00 0237 383 0	HEXAGON HEAD BOLT	M10X25	16	
7	00 0215 683 0	WASHER	10,5	16	
8	00 0237 572 0	HEXAGON HEAD BOLT	M12X35	4	
9	00 1301 406 0	WASHER	13 ST A2C	4	
10	00 1307 597 0	MOTORLAGERUNG KPL.	115 KW	1	
11	00 0237 761 1	SOCKET HEAD SCREW	M12X 30	8	
12	00 1304 775 0	BEARING	KPLT.	2	
13	00 1304 374 0	BEARING	30/31	2	
14	00 1305 311 0	FLANGE	F. KUPPLUNG	1	
15	00 1304 397 0	CLUTCH		1	
16	50 0300 903 6	HEX. SOCKET CHEESE-HEAD SCREW	M10X20	8	
17	00 0223 022 0	STUD BOLT	M10X20	2	
18	00 0236 171 0	HEXAGONAL NUT	M10	2	
19	00 0479 671 0	ADJUSTING DISC	14X60X1,0	1	
20	00 0479 670 0	ADJUSTING DISC	14X60X0,5	1	
21	00 0479 672 0	ADJUSTING DISC	14X60X1,5	1	
22	00 0235 495 1	SOCKET HEAD SCREW	M10X 25	10	
23	00 0235 585 0	HEXAGON HEAD BOLT	M16X45	1	

1) Remarks LRC

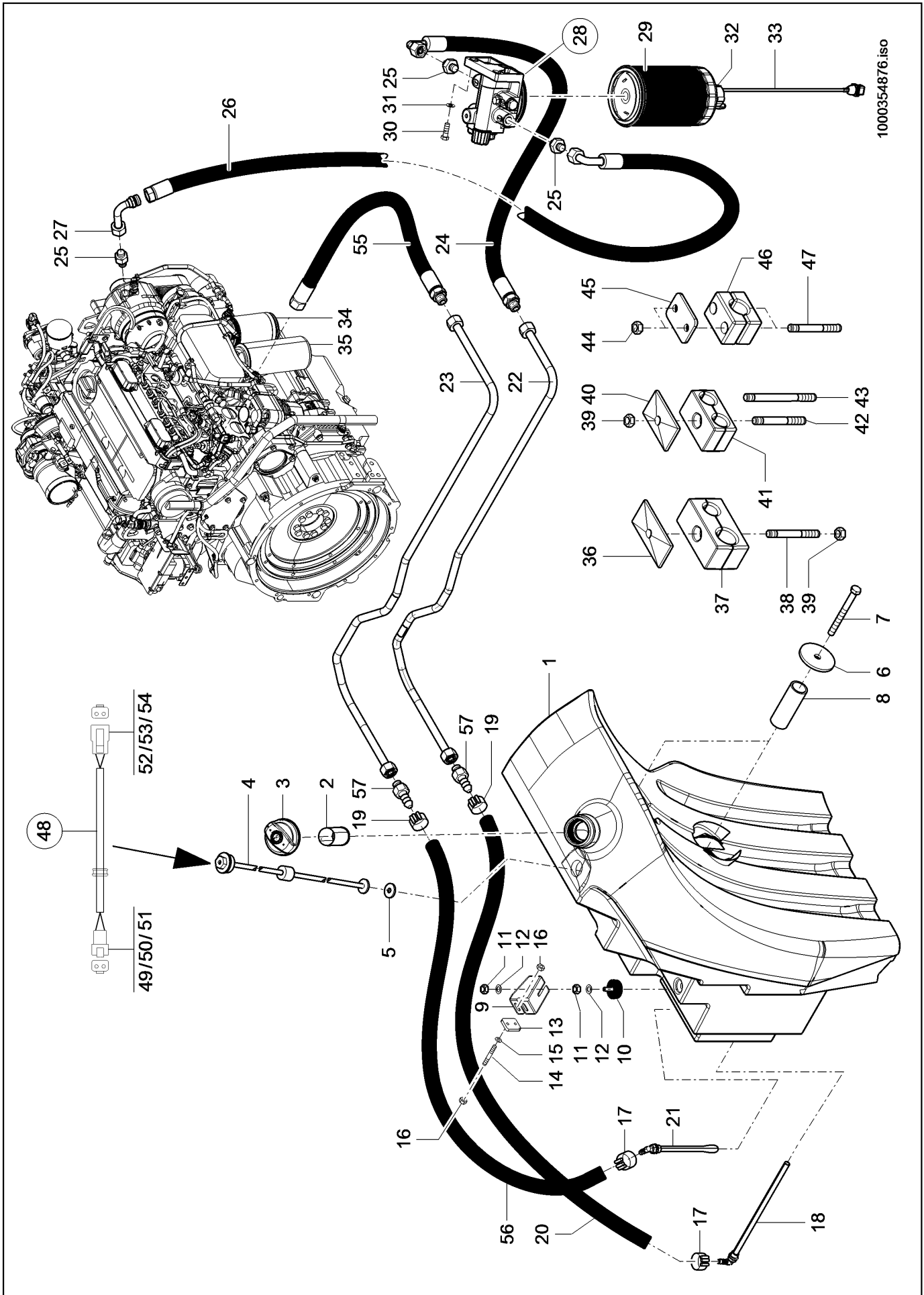

100 FUEL TANK

Pos.	Part No.	Description	Dimension	Quantity	Conditions
1	00 1307 430 0	FUEL TANK		1	
2	00 1302 051 0	FILL IN STRAINER		1	
3	00 1305 708 0	LOCKING COVER	KRAFTSTOFFTANK	1	
4	00 1304 386 0	SENDER UNIT	985 MM LG.	1	
5	#NV			1	
6	00 1301 418 0	WASHER		2	
7	00 0215 898 0	HEXAGON HEAD BOLT	M16X160	2	
8	00 1300 436 0	SPACER TUBE		2	
9	00 1304 610 0	SUPPORT		1	
10	00 1304 375 0	BUFFER BUMPER	D 50X18-M10X38	1	
11	00 0238 316 0	LOCK NUT	M10	2	
12	00 0237 592 0	WASHER	D10,5X30X2,5	2	
13	00 1304 795 0	THREADED PLATE		1	
14	00 0215 437 0	STUD BOLT	M 8X 25	2	
15	00 0237 816 0	WASHER	8-8,4X24X2	2	
16	00 0238 132 0	LOCK NUT	M8	2	
17	00 0223 019 0	CLAMP	COBRA 19/8	1	
18	00 1307 616 0	SOCKET	"WES-12-R 1/2"" 381	1	
19	00 1301 801 0	CLAMP	MM 18,5-20,	1	
20	00 1306 776 0	FUEL HOSE	0X8-COBRA18/8-WE 12X3,5X5000	2	
21	00 1307 615 0	SOCKET	"WES-12-R 1/2"" 223	1	
22	00 1304 757 0	PIPE	MM L KPLT.	1	
23	00 1304 756 0	PIPE	KPLT.	1	
24	00 1305 405 0	HOSE PIPE		1	
25	00 1301 591 0	SCREW-IN FITTING	SDS-L15XM16X1, 5-TYPE E	3	
26	00 1305 399 0	HOSE PIPE		1	
27	00 1301 079 0	TUBE ELBOW	L15 (M22X1,5) A3C	1	
28	00 1302 434 0	FILTER HEAD		1	
29	00 1993 117 0	FILTER CARTRIDGE		1	
30	00 0237 383 0	HEXAGON HEAD BOLT	M10X25	2	
31	00 0215 683 0	WASHER	10,5	2	
32	00 1993 119 0	SEALING RING		1	
33	00 1993 118 0	SENSOR CABLE		1	
34	00 1302 277 0	FUEL FILTER		1	
35	00 1302 276 1	ENGINE OIL FILTER		1	
36	00 0313 226 0	COVER PLATE	Z DP-3-W3	1	
37	00 1301 454 0	CLAMP	Z KP-3-R-20-15-PP	1	
38	00 0147 145 0	STUD BOLT	M 8X 65	1	
39	00 0238 132 0	LOCK NUT	M8	3	
40	00 0216 994 0	COVER PLATE	Z DP-2-W1	2	
41	00 1301 443 0	CLAMP	Z KP-2-R-15-15-PP	2	
42	00 1301 537 0	STUD BOLT	M08X45	1	
43	00 1301 539 0	STUD BOLT	M8X75-8.8 A2C	1	
44	00 0211 113 0	LOCK NUT	M6	6	
45	00 0211 538 0	COVER PLATE	L DP-2-W1	3	
46	00 1301 447 0	CLAMP	L KP-3-R-20-PA	1	
47	00 0219 932 0	STUD BOLT	M 6X 50	1	
48	00 1306 653 0	WIRE	KRAFTSTOFFVERSOR GUNG	1	
49	00 0326 892 0	PIN HOUSING	2-POLIG	1	
50	00 1301 785 0	PLUG	1,0 - 2,0	1	

100 FUEL TANK

Pos.	Part No.	Description	Dimension	Quantity	Conditions
51	00 1301 763 0	V-SHAPED ELEMENT	2-POLIG	1	
52	00 0311 341 0	PLUG	2-POLIG	1	
53	00 1300 122 0	BUSHING CONTACT	1,0 - 2,0	1	
54	00 0311 306 0	RETENTION	2-POLIG	1	
55	00 1307 592 0	HOSE PIPE		1	
56	00 1306 776 0	FUEL HOSE	12X3,5X5000	0	
57	00 1307 618 0	HOSE FITTING	S L15 X 12 DN 12 C	2	

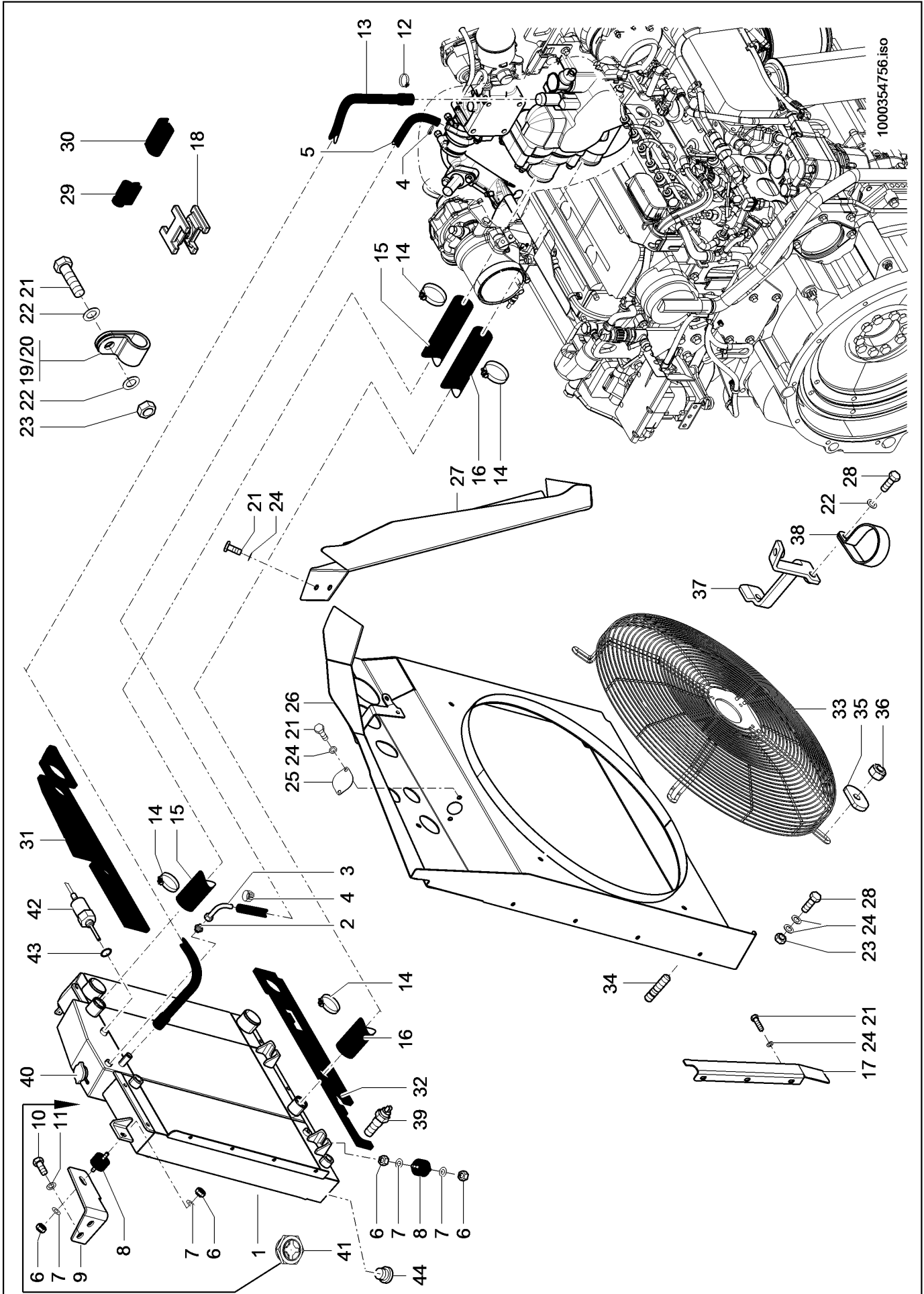

140 ENGINE COOLER

Pos.	Part No.	Description	Dimension	Quantity	Conditions
1	00 1307 497 0	RADIATOR	KOMBI HYDRAULIKÖL	1	
2	00 0212 933 0	SCREW-IN FITTING	SDS-L12XM12X1, 5-TYPE B	1	
3	00 0142 279 0	TUBE NIPPLE	DN10 - N90 L12 (M18X1,5)	1	
4	00 1302 315 0	CLAMP	COBRA 16/8	2	
5	00 1305 496 0	FUEL HOSE	10X3X2,50 M	2	
6	00 0238 316 0	LOCK NUT	M10	6	
7	00 0237 592 0	WASHER	D10,5X30X2,5	6	
8	00 1304 412 0	BEARING	D 50X30 M 10X25	3	
9	00 1303 169 0	SUPPORT		1	
10	00 0237 570 0	HEXAGON HEAD BOLT	M10X16	2	
11	00 0237 592 0	WASHER	D10,5X30X2,5	2	
12	00 1302 911 0	HOSE CLAMP	B1-30X15	2	
13	00 1307 471 0	PRESHAPED TUBE	ENTLÜFTUNG KÜHLER	1	
14	00 0217 447 0	HOSE CLAMP	B1-58X15	4	
15	00 1307 475 0	PRESHAPED TUBE	KÜHLWASSER	1	
16	00 1307 568 0	PRESHAPED TUBE	KÜHLER	1	
17	00 1307 313 0	LEDGE		1	
18	00 1305 220 0	CONNECTION	DSWS4 26,3X20,3X18,01		
19	00 0364 814 1	HOLDER CLAMP	D1-25X25	1	
20	00 0812 991 0	HOLDER CLAMP	D1-15X20	1	
21	00 0237 439 0	HEXAGON HEAD BOLT	M8X16	9	
22	00 0215 682 0	WASHER	8,4	3	
23	00 0238 132 0	LOCK NUT	M8	12	
24	00 0215 682 0	WASHER	8,4	28	
25	00 1304 699 0	PLATE		1	
26	00 1307 498 0	AIR INTAKE HSG.		1	
27	00 1307 287 0	DIVIDER PLATE		1	
28	00 0237 442 0	HEXAGON HEAD BOLT	M8X25	11	
29	00 1300 167 0	PROFILE	1STÜCK=2METER KLEMMBEREI	4	
30	00 1300 171 0	PROFILE	1,0-3, 5KLEMMBR.ERS.D.130	0	
31	00 1304 827 0	GASKET		1	
32	00 1304 828 0	GASKET		1	
33	00 1304 713 0	GUARD SCREEN		1	
34	00 0215 437 0	STUD BOLT	M 8X 25	4	
35	00 1302 871 0	WASHER	N.Z.	4	
36	00 0238 132 0	LOCK NUT	M8	4	
37	00 1307 586 0	SUPPORT CPL.	KUEHLER	1	
38	00 0217 309 0	HOLDER CLAMP	D1-60X25	1	
39	00 1300 175 0	TEMPERAT.FEELER	40 - 120°C - M14X1,5	1	
40	00 1307 054 0	LOCKING COVER	F. ÖL-WASSER-KÜHLER 1304	1	
41	00 0223 259 0	OIL INDICATEUR	M20X1,5	1	
42	00 1306 955 0	SENSOR		1	
43	00 0597 302 0	SEALING RING	A14X20X1,5	1	
44	00 0656 014 1	SCREW PLUG	M14X1,5	1	

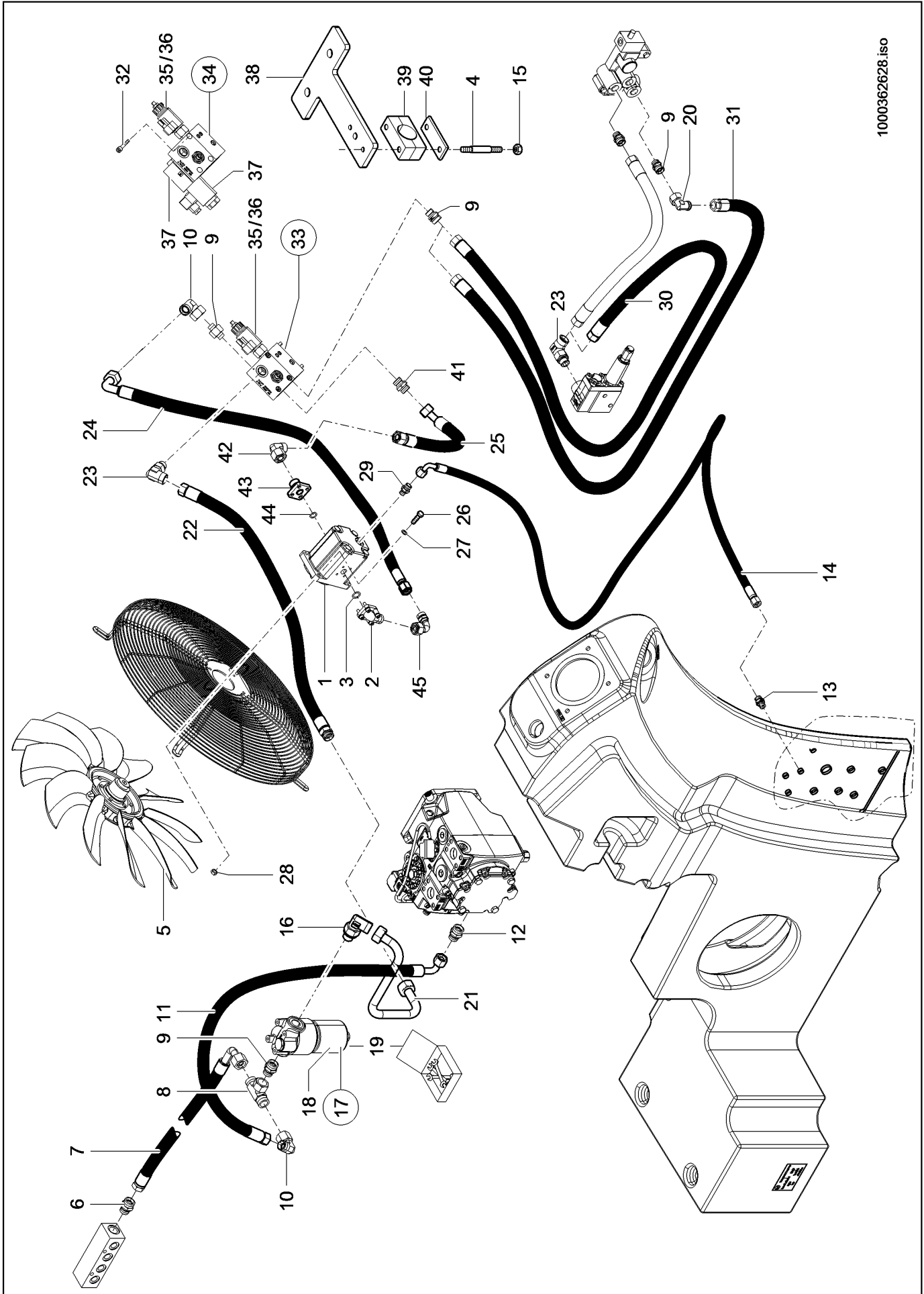

1000362628.iso

140 ENGINE COOLER

Pos.	Part No.	Description	Dimension	Quantity	Conditions
1	00 1304 427 0	HYDRAULIC MOTOR	17 CM ³	1	
2	00 0808 783 0	ANGLE FLANGE	WFS-L15-LK35	1	
3	00 1301 341 0	O-RING	20X2,5-N	1	
4	00 1301 536 0	STUD BOLT	M6X55	2	
5	00 1304 663 0	FAN WHEEL		1	
6	00 0689 148 1	SCREW-IN FITTING	SDS-L15XM18X1, 5-TYPE E-R	1	
7	00 1305 393 0	HOSE PIPE		1	
8	00 0249 853 0	T-UNION, ADJUSTM.	SWOBT-L18	1	
9	00 0249 780 0	SCREW-IN FITTING	SDS-L18XG1/2A-TYPE E	1	
10	00 0249 837 0	ANGLE UNION	SWOE-L18	2	
11	00 0141 062 0	HOSE PIPE		1	
12	00 0217 033 0	SCREW-IN FITTING	SDS-L18X1	1	
13	00 0250 004 0	SCREW-IN FITTING	1/16-12UN-2A-T SDS-L10XM14X1, 5-TYPE E	1	
14	00 1305 345 0	HOSE PIPE		1	
15	00 0211 113 0	LOCK NUT	M6	2	
16	00 1301 603 0	SCREW-IN FITTING	SDE-L18XM22X1, 5-TYPE H	1	
17	00 1301 037 0	FAN CASE		1	
18	00 1300 257 0	HYDRAULIC FILTER		1	
19	00 0845 872 0	SEAL KIT		1	
20	00 0249 837 0	ANGLE UNION	SWOE-L18	1	1)
21	00 1304 820 0	PIPE	KPLT.	1	
22	00 1305 341 0	HOSE PIPE		1	
23	00 1301 577 0	SCREW-IN FITTING	SDE-L18XG1/2A-TYPE H	2	
24	00 1303 416 0	HOSE PIPE		1	
25	00 1307 581 0	HOSE PIPE		1	
26	00 0237 442 0	HEXAGON HEAD BOLT	M8X25	4	
27	00 0215 682 0	WASHER	8,4	4	
28	00 0238 132 0	LOCK NUT	M8	4	
29	00 0249 774 0	SCREW-IN FITTING	SDS-L10XG1/4A-TYPE E	1	
30	00 1305 401 0	HOSE PIPE		1	2)
31	00 1305 325 0	HOSE PIPE		1	1)
32	00 1992 832 0	SOCKET HEAD SCREW	M8X60	3	
33	00 1304 390 0	VALVE		1	
34	00 1304 389 0	REVERSING VALVE		1	
35	00 1304 428 0	SOLENOID VALVE		1	
36	00 1307 412 0	SOLENOID	M19P-12D-1.1A-DE	1	
37	00 1304 429 0	SOLENOID		1	
38	00 1304 792 0	SUPPORT		1	
39	00 0325 088 0	CLAMP	L KP-3-R-22-PP	1	
40	00 1300 066 0	COVER PLATE	L DP-3-W1	1	
41	00 0249 779 0	UNION	SDS-L15XG1/2A-TYPE E	1	
42	00 0249 836 0	ANGULAR MALE CONNECTOR	SWOE-L15	1	
43	00 0573 442 0	FLANGE SUPPORT	GFS-L15-LK35-L23- OMD	1	
44	00 1301 341 0	O-RING	20X2,5-N	1	
45	00 1304 953 0	CONNECTOR	N(L15) - D(L15) 90°	1	

1) Remarks

option

140 ENGINE COOLER

2) Remarks

series

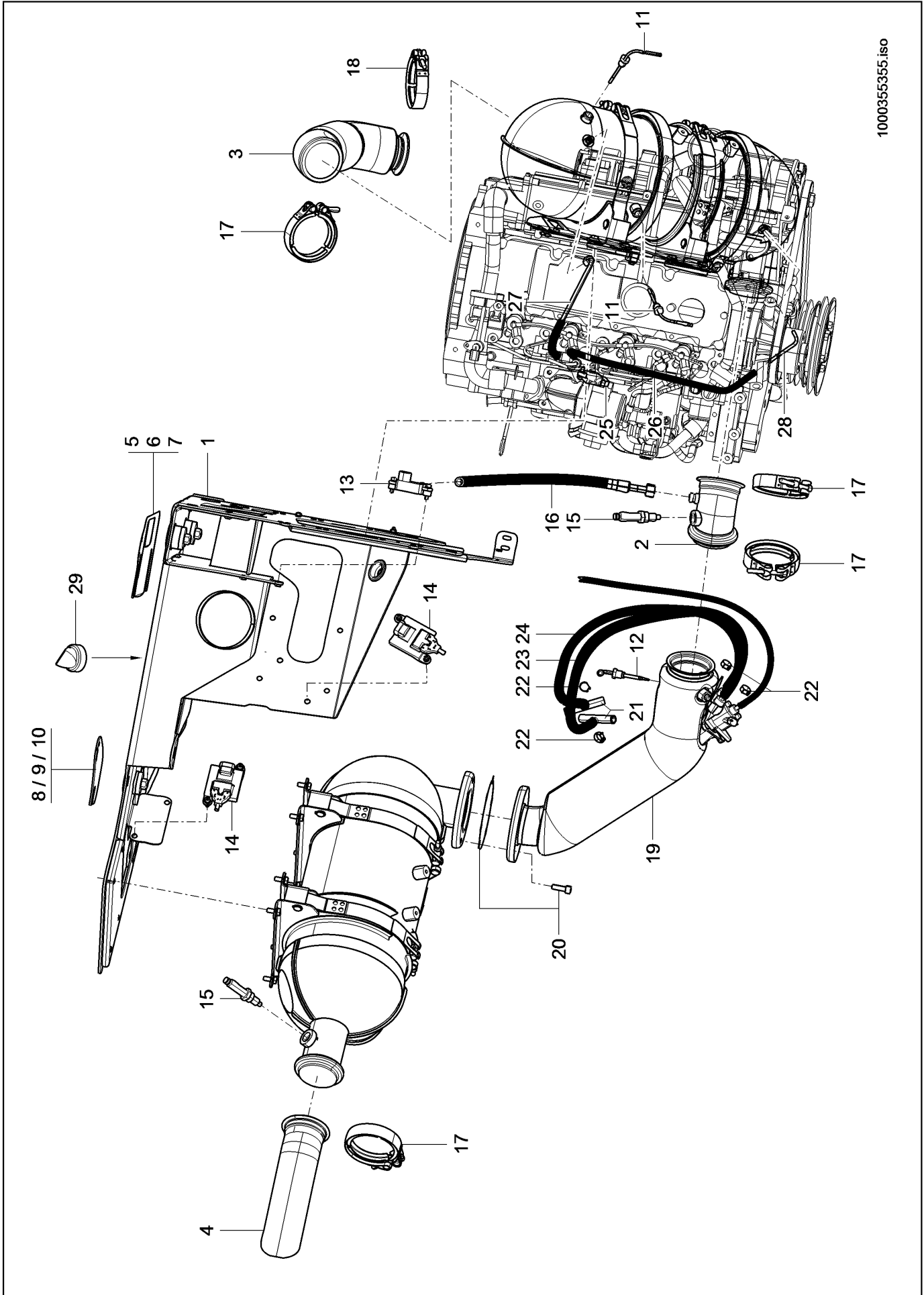

1000355355.iso

Thank you so much for reading.
Please click the “Buy Now!”
button below to download the
complete manual.



After you pay.

You can download the most
perfect and complete manual in
the world immediately.

Our support email:

ebooklibonline@outlook.com