

010 COMPLETE ENGINE 1)

Pos.	Part No.	Description	Dimension	Quantity	Conditions
10		VORMONTAGE MOTOR		1	2)
20		BEFESTIGUNG MOTORSTEUERGERAET		1	3)
1)	machine no.				
				+ 0	
				+ K3700021	
				+ K3700022	
				+ K3700023	
				+ K3700024	
				+ K3700025	
				+ K3700026	
				+ K3700027	
				+ K3700028	
				+ K3700029	
2)	Remarks				-> BGZ 01 02 010 -> Drawing no.: 053055
3)	Remarks				-> BGZ 01 55 050 -> Drawing no.: 053057

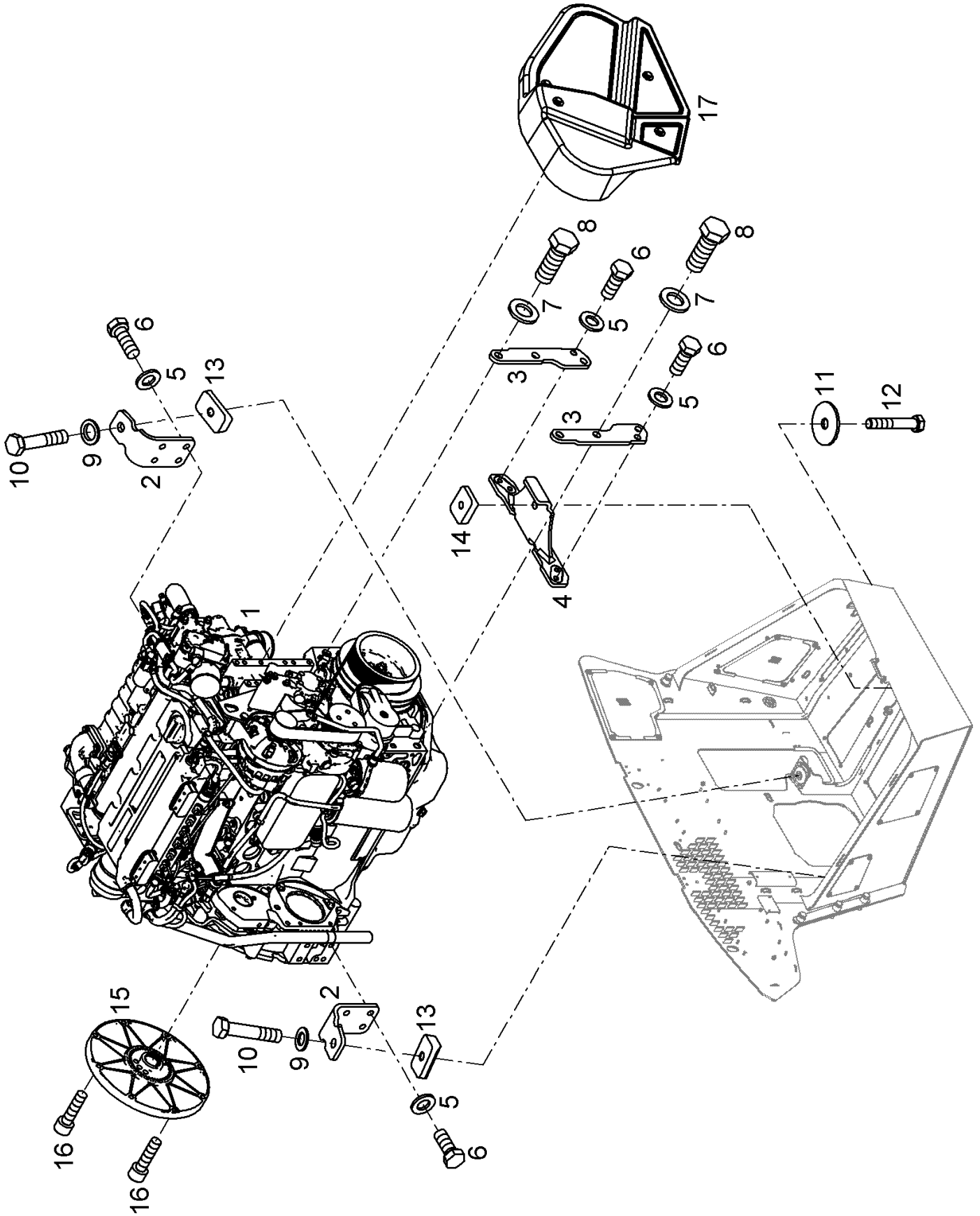

010 COMPLETE ENGINE 1)

Pos.	Part No.	Description	Dimension	Quantity	Conditions
1	00 1921 154 0	DIESEL ENGINE	TCD 4.1 115KW T4F SCR	1	
2	00 1922 257 0	SUPPORTING PLATE	LAGERUNG MOTOR	2	
3	00 1922 532 0	LAGERFUSS	ENGINE	2	
4	00 1922 594 0	BEARING PLATE	ENGINE	1	
5	00 0213 801 0	FLAT WASHER	12-13X24X2,5	12	
6	00 0233 456 0	HEXAGON HEAD BOLT	M12X30	12	
7	00 0250 059 0	FLAT WASHER	16 -17X30X3	4	
8	00 0238 662 1	HEXAGON HEAD BOLT	M16X45	4	
9	00 0214 560 0	WASHER	20 - 21X37X3	2	
10	77 0300 168 1	HEXAGON HEAD BOLT	M20X100	2	
11	00 1920 401 0	WASHER	17X69X4	1	
12	00 0214 244 0	HEXAGON HEAD BOLT	M16X90	1	
13	00 1922 400 0	THREADED PLATE	ENGINE	2	
14	00 1920 343 0	THREADED PLATE	ENGINE	1	
15	00 1922 114 0	COUPLING	ENGINE PF 3	1	
16	00 1992 839 1	hexagon socket head cap screw	M10X35 ERS.D.1994520.0	8	
17		BELT GUARD		1	2)
1)	machine no.		+ 0 + K3700021 + K3700022 + K3700023 + K3700024 + K3700025 + K3700026 + K3700027 + K3700028 + K3700029		
2)	Remarks		-> BGZ 01 50 140 -> Drawing no.: 053058		

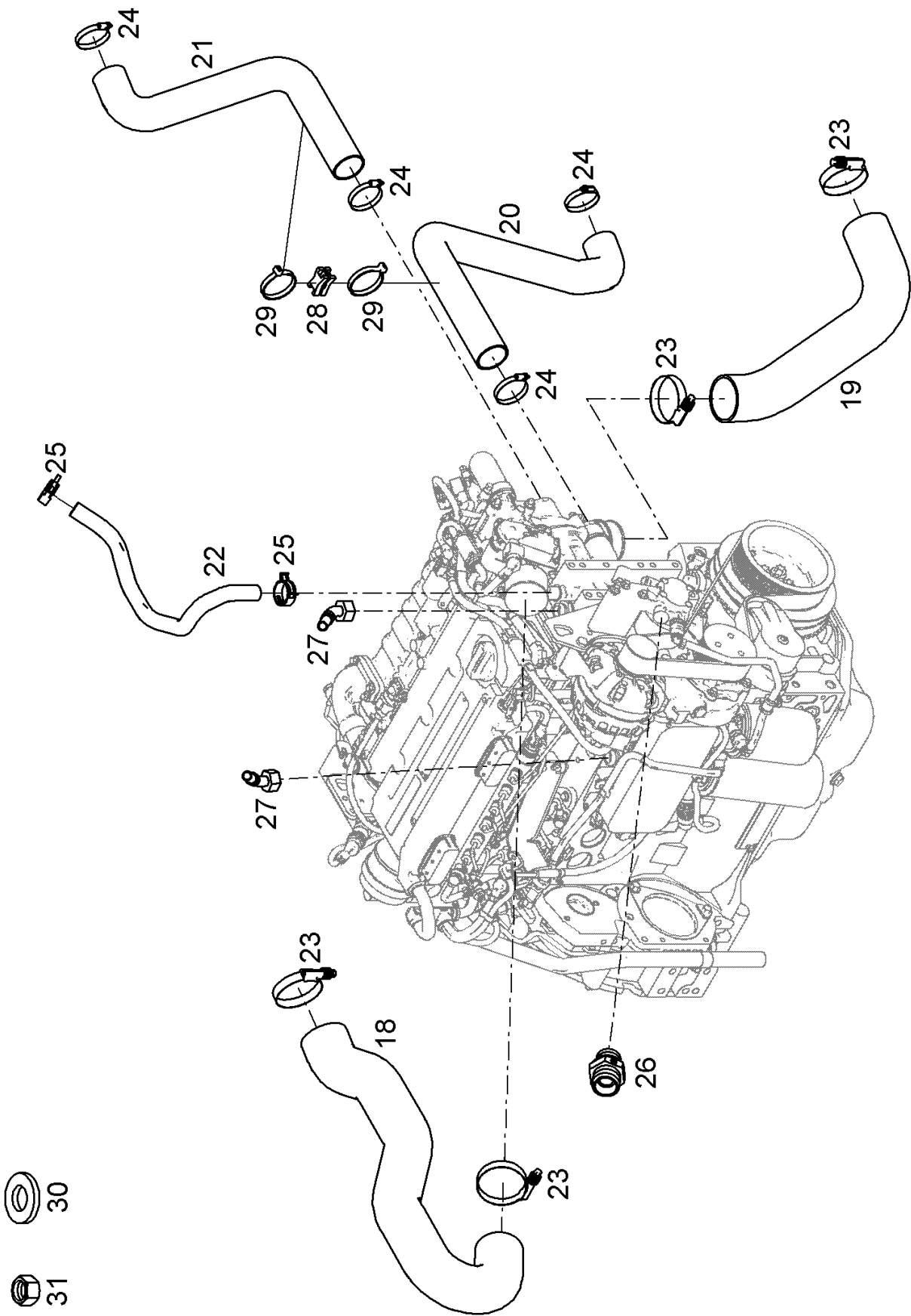

010 COMPLETE ENGINE 1)

Pos.	Part No.	Description	Dimension	Quantity	Conditions
18	00 1921 663 0	CHARGE AIR HOSE	DIESELMOTOR	1	
19	00 1921 664 0	CHARGE AIR HOSE	DIESELMOTOR	1	
20	00 1922 652 0	KUEHLWASSERSCHLAUCH	DIESELMOTOR	1	
21	00 1921 681 0	KUEHLWASSERSCHLAUCH	50 X ??	1	
22	00 1921 682 0	KUEHLWASSERSCHLAUCH	22 X ??	1	
23	00 1302 314 0	CLAMP	362-TYPE SLHD 70-92X16-S	4	
24	00 0224 097 0	SCHELLE MIT TE-FED	40-60X14,3	4	
25	00 1995 050 0	SPRING BAND CLAMP	A-30X12	2	
26	00 0216 097 0	STRAIGHT MALE CONNECTOR	SDS-L12XM16X1, 5-TYPE E	1	
27	00 1921 559 0	HOSE FITTING	SWE45 18X16(M26X1, 5)45 2	2	
29	00 0177 626 0	PVC BINDING AGENT	450 X 8,9MM	2	
30	00 1921 453 0	WASHER	21X70X5	2	
31	00 0224 398 0	HEX. NUT WITH CLAMP. PART	M20	2	

1)	machine no.	+ 0
		+ K3700021
		+ K3700022
		+ K3700023
		+ K3700024
		+ K3700025
		+ K3700026
		+ K3700027
		+ K3700028
		+ K3700029

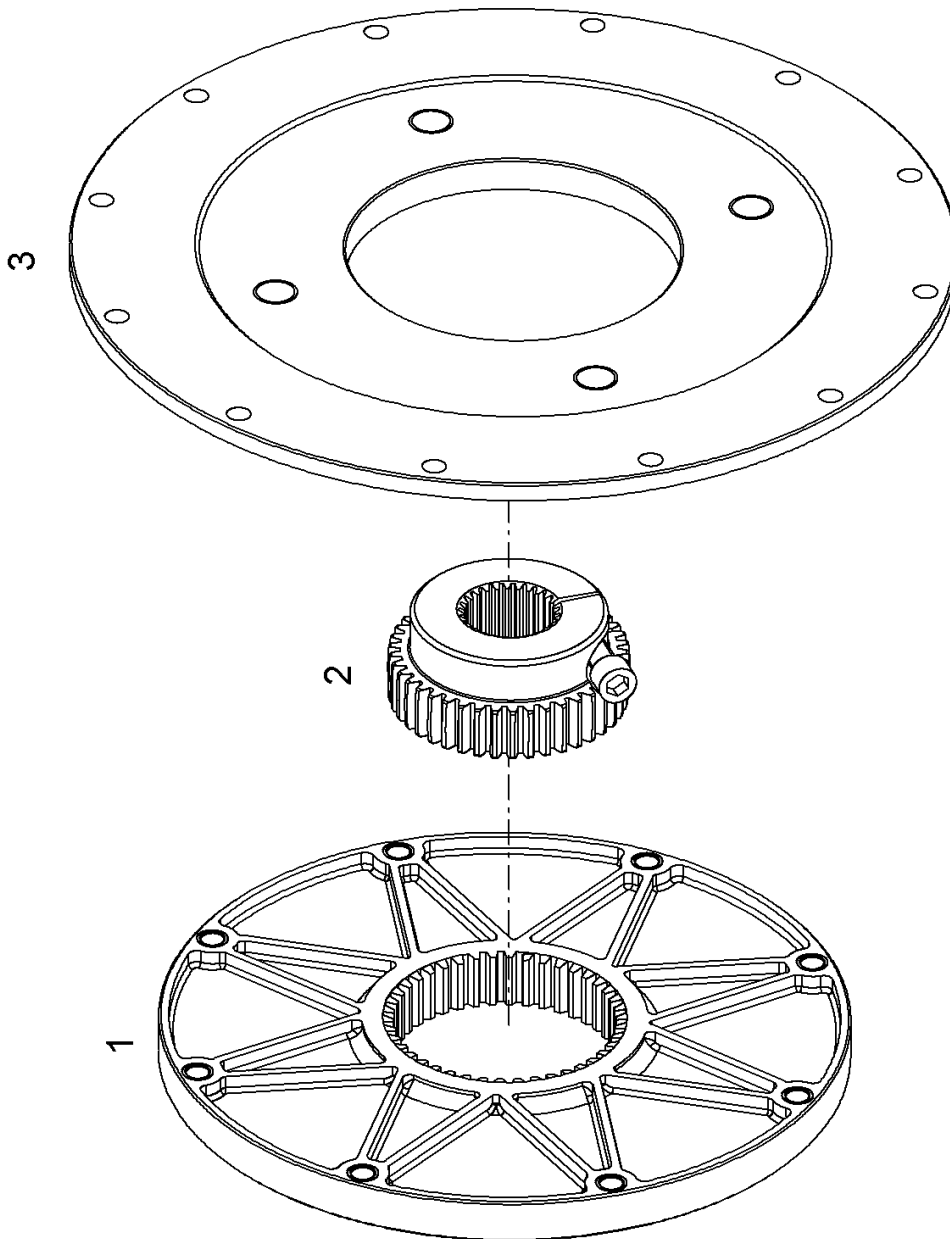

010 COMPLETE ENGINE 1)

Pos.	Part No.	Description	Dimension	Quantity	Conditions
1	00 1921 186 0	FLANGE		1	
2	00 1922 113 0	CLAMPING HUB		1	
3	00 1922 115 0	FLANGE		1	
1)	machine no.				
			+ 0		
			+ K3700021		
			+ K3700022		
			+ K3700023		
			+ K3700024		
			+ K3700025		
			+ K3700026		
			+ K3700027		
			+ K3700028		
			+ K3700029		

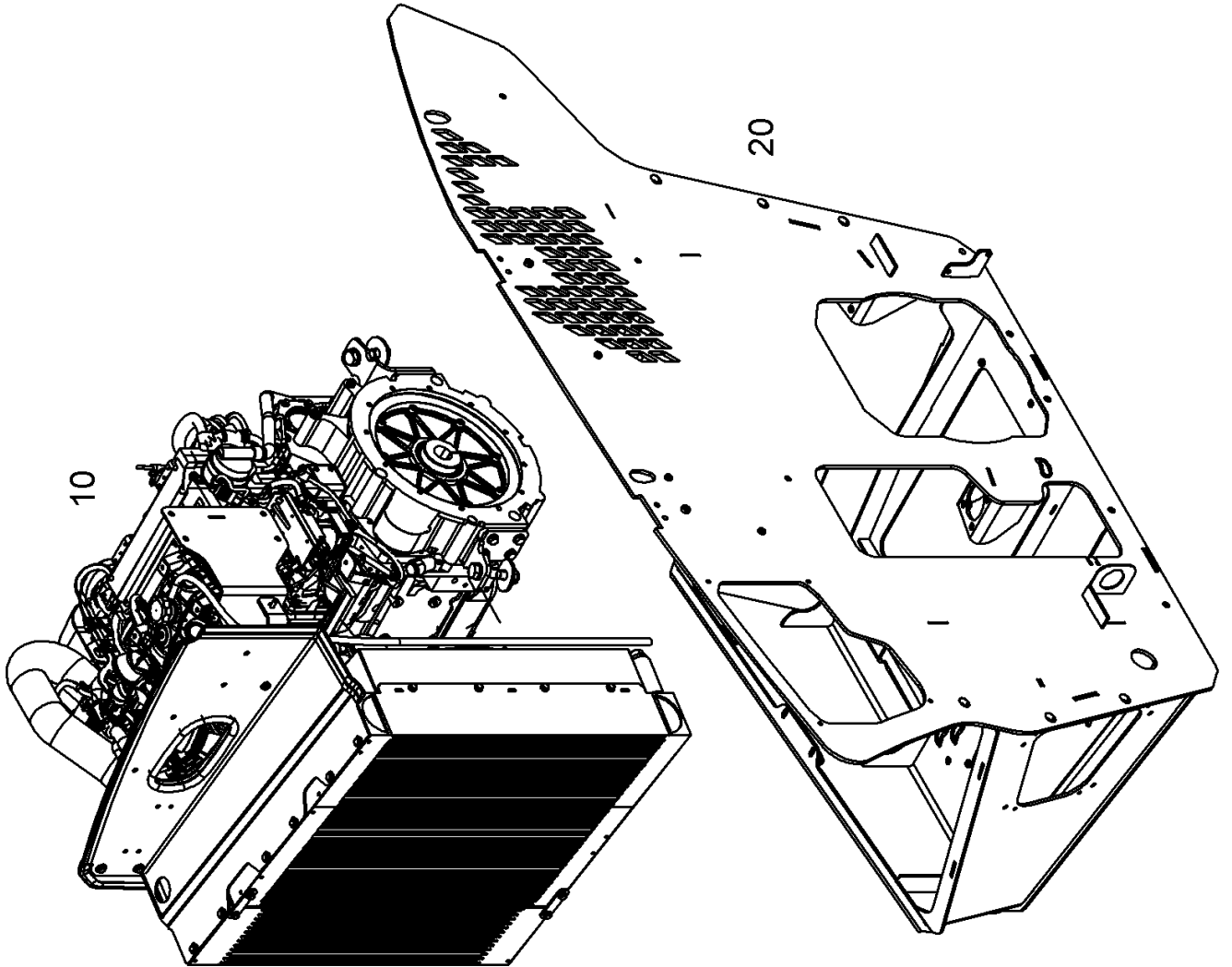

010 COMPLETE ENGINE 1)

Pos.	Part No.	Description	Dimension	Quantity	Conditions
10	ERS08	ORDER SINGLE PARTS		1	
20		BEFESTIGUNG MOTORSTEUERGERAET		1	2)
1)	machine no.				
		+ 0			
		+ K3700616			
		+ K3700622			
		+ K3700660			
		+ K3700687			
		+ K3700699			
		+ K3700700			
		+ K3700706			
		+ K3700712			
		ENGINE ARRANGEMENT			
2)	Remarks				
		-> BGZ 01 55 050 -> Drawing no.: 053057			

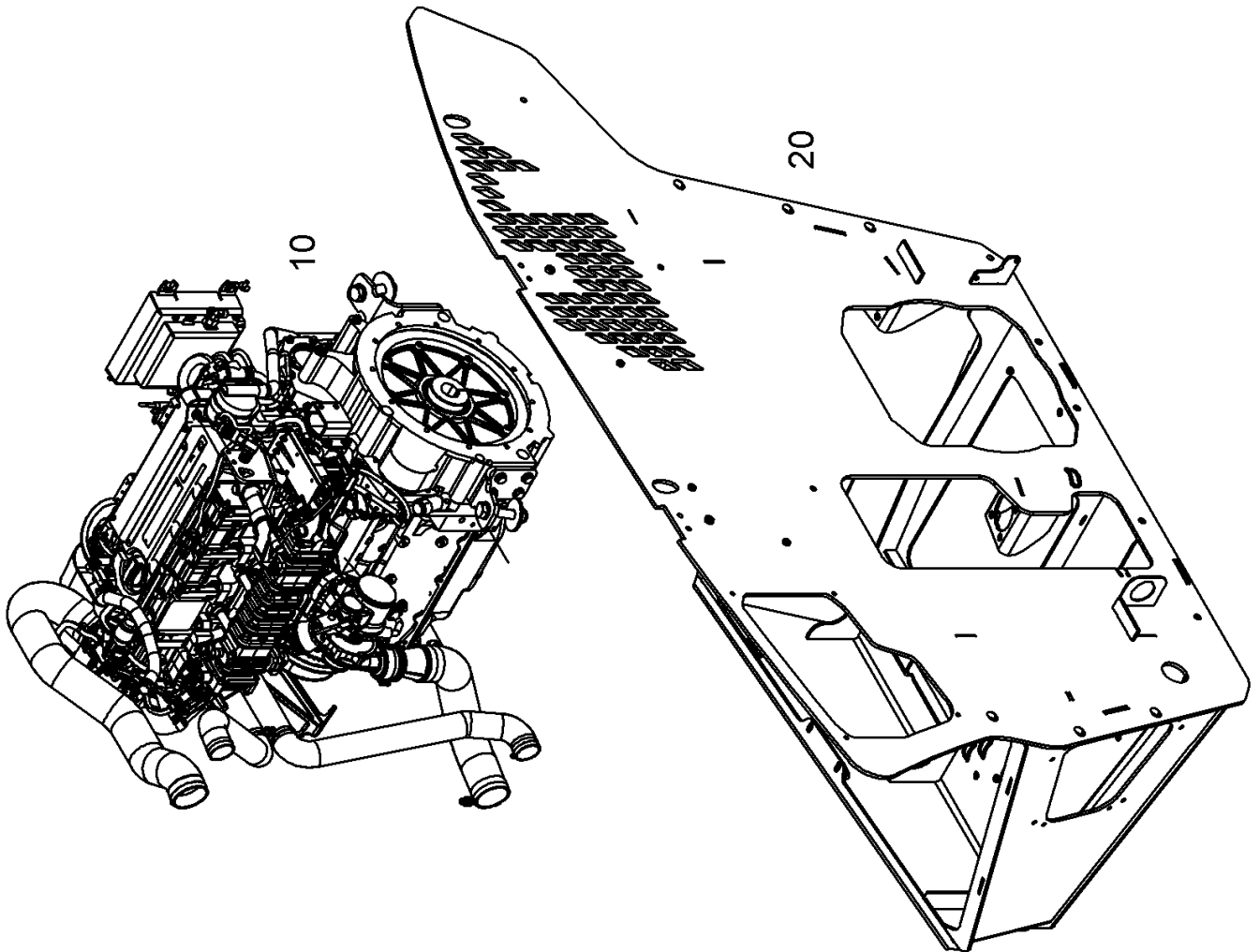

010 COMPLETE ENGINE 1)

Pos.	Part No.	Description	Dimension	Quantity	Conditions
10	ERS08	ORDER SINGLE PARTS		1	
20		BEFESTIGUNG MOTORSTEUERGERAET		1	2)
1)	machine no.				
		+ 0			
		+ K3700600			
		+ K3700601			
		+ K3700602			
		+ K3700603			
		+ K3700604			
		+ K3700605			
		+ K3700606			
		+ K3700607			
		+ K3700608			
2)	Remarks				
					-> BGZ 01 55 050 -> Drawing no.: 053057

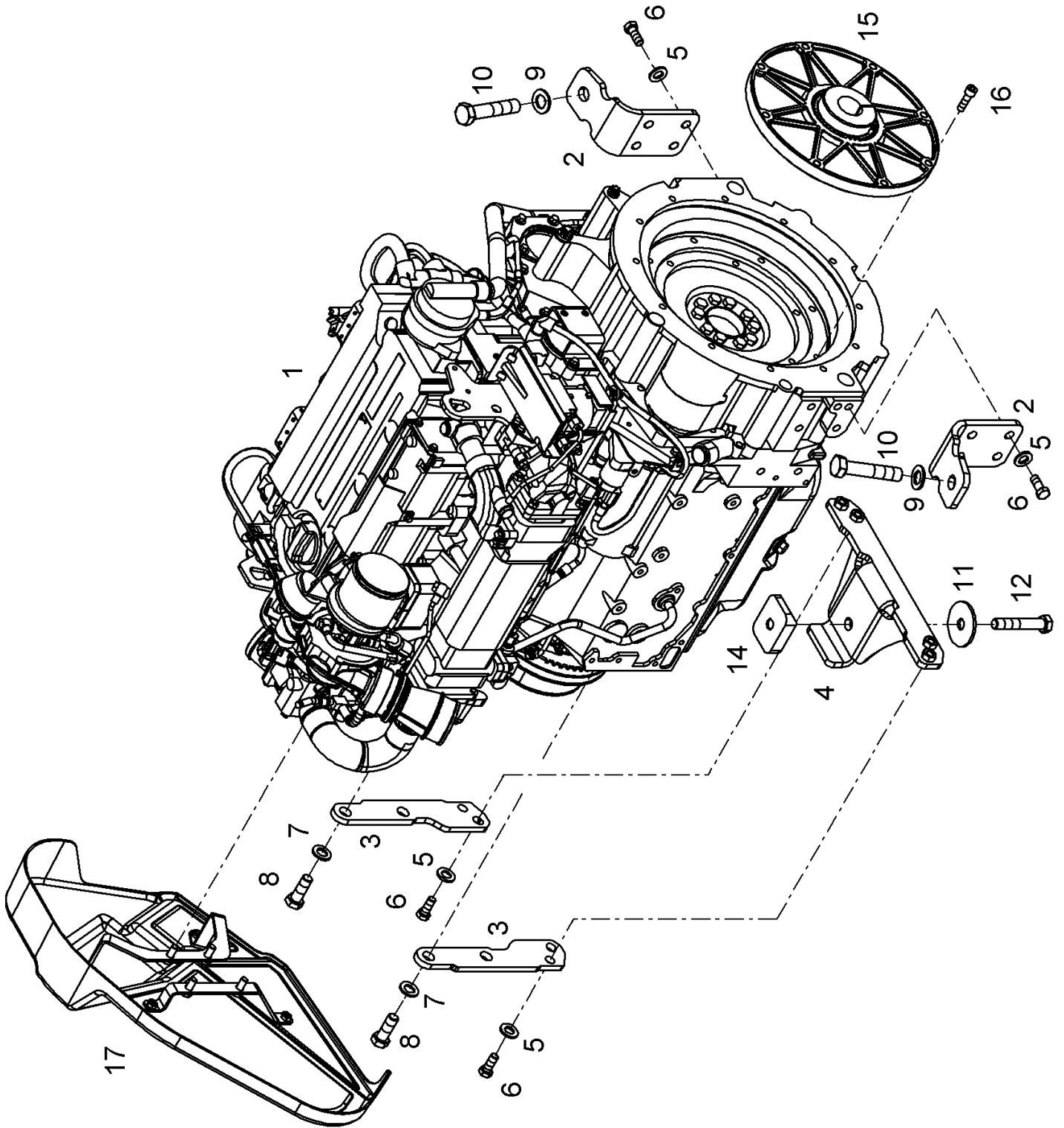

010 COMPLETE ENGINE 1)

Pos.	Part No.	Description	Dimension	Quantity	Conditions
1	00 1922 464 0	DIESEL ENGINE	TCD 4.1 115KW TIER3A	1	
2	00 1922 257 0	SUPPORTING PLATE	LAGERUNG MOTOR	2	
3	00 1922 532 0	LAGERFUSS	ENGINE	2	
4	00 1922 594 0	BEARING PLATE	ENGINE	1	
5	00 0213 801 0	FLAT WASHER	12-13X24X2,5	12	
6	00 0233 456 0	HEXAGON HEAD BOLT	M12X30	12	
7	00 0250 059 0	FLAT WASHER	16 -17X30X3	4	
8	00 0238 662 1	HEXAGON HEAD BOLT	M16X45	4	
9	00 0214 560 0	WASHER	20 - 21X37X3	2	
10	77 0300 168 1	HEXAGON HEAD BOLT	M20X100	2	
11	00 1920 401 0	WASHER	17X69X4	1	
12	00 0214 244 0	HEXAGON HEAD BOLT	M16X90	1	
14	00 1920 343 0	THREADED PLATE	ENGINE	1	
15	00 1922 114 0	COUPLING	ENGINE PF 3	1	
16	00 1992 839 1	hexagon socket head cap screw	M10X35 ERS.D.1994520.0	8	
17		BELT GUARD		1	2)
1)	machine no.		+ 0 + K3700616 + K3700622 + K3700660 + K3700687 + K3700699 + K3700700 + K3700706 + K3700712 PRE ASSEMBLY ENGINE		
2)	Remarks		-> BGZ 01 50 140 -> Drawing no.: 053058		

Thank you so much for reading.
Please click the “Buy Now!”
button below to download the
complete manual.



After you pay.

You can download the most
perfect and complete manual in
the world immediately.

Our support email:

ebooklibonline@outlook.com