

100 ENGINE SUSPENSION 1)

1) machine no.

+ 0
+ K5500201
MOTOR

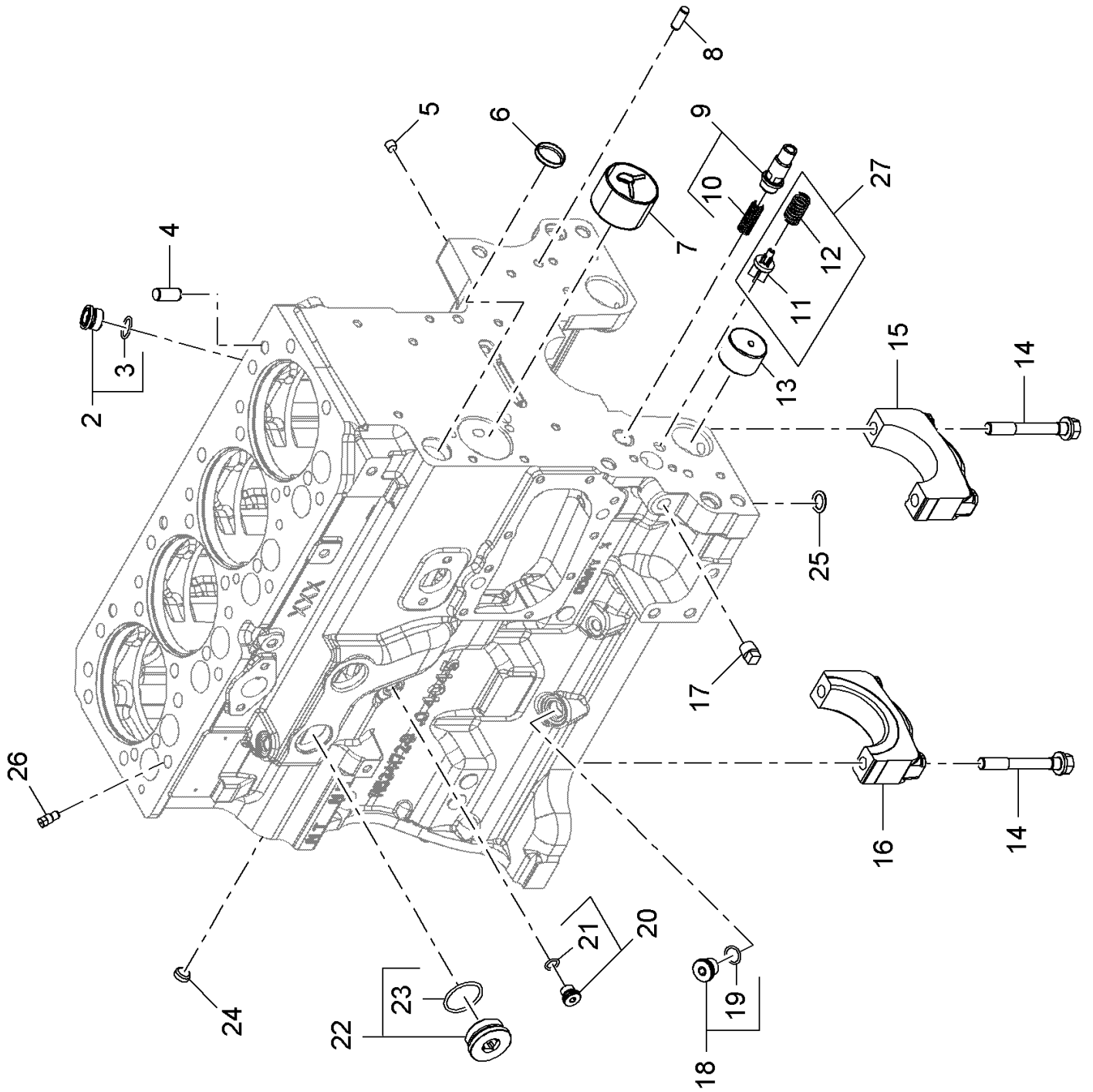

100 CRANKCASE 1)

Pos.	Part No.	Description	Dimension	Quantity	Conditions
2	00 1145 914 0	BLANKING COVER		1	
3	60 0502 160 4	O-RING	19X2.4	1	
4	60 0501 317 4	CENTRING PIN		4	
5	00 1953 170 0	TUBE PLUG		5	
6	60 0502 143 9	BLANKING COVER		1	
7	60 0501 294 1	BEARING		1	
8	60 0501 319 6	CENTRING PIN		2	
9	60 0502 869 1	VALVE		1	
10	60 0502 593 4	SPRING		1	
11	00 1145 875 0	VALVE		1	
12	60 0501 320 1	SPRING		1	
13	60 0502 593 1	RING		6	
14	00 1953 774 0	HEXAGON HEAD BOLT		10	
15	60 0502 143 8	COVER		4	
16	ERS11	PART HAS NOT BEEN INSTALLED		1	
17	60 0501 597 1	LOCK		1	
18	00 1145 876 0	PLUG		2	
19	60 0502 160 8	O-RING	15,3X2,2-N	1	
20	00 1145 880 0	PLUG		3	
21	60 0502 164 1	O-RING		1	
22	60 0502 905 2	PLUG		2	
23	60 0501 321 5	O-RING		1	
24	60 0501 319 8	BLANKING COVER		2	
25	60 0501 320 3	O-RING		1	
26	60 0502 143 6	SPRAY NOZZLE		4	
27	60 0501 402 9	VALVE		1	
1)	machine no.		+ 0 + K5500201 CYLINDER BLOCK		

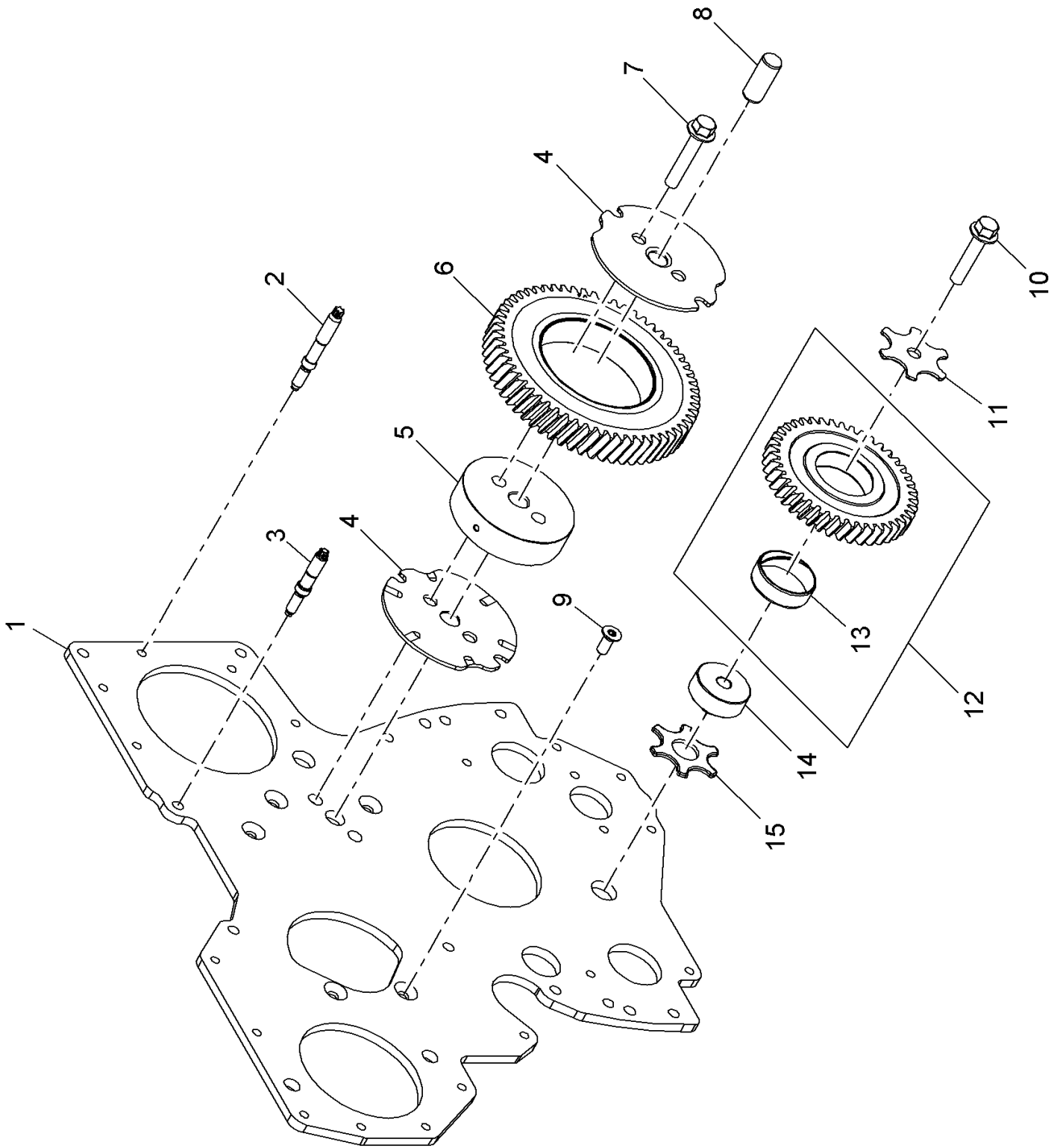

100 CRANKCASE 1)

Pos.	Part No.	Description	Dimension	Quantity	Conditions
1	00 1953 169 0	PLATE		1	
2	00 1132 473 0	STUD BOLT		7	
3	60 0502 339 8	STUD BOLT		2	
4	00 1161 412 0	WASHER		2	
5	00 1161 413 0	HUB		1	
6	00 1132 544 0	WHEEL		1	
7	00 1169 744 0	STD SCREW	M10X55	2	
8	00 1132 541 0	LOCATING PIN		1	
9	60 0502 339 7	SCREW		5	
10	00 1145 932 0	SCREW	M10X50	1	
11	60 0502 152 2	WASHER		1	
12	60 0502 151 9	WHEEL		1	
13	60 0502 152 0	RING		1	
14	60 0502 152 3	SHAFT		1	
15	60 0501 299 8	WASHER		1	

1) machine no. + 0
+ K5500201
SHEET

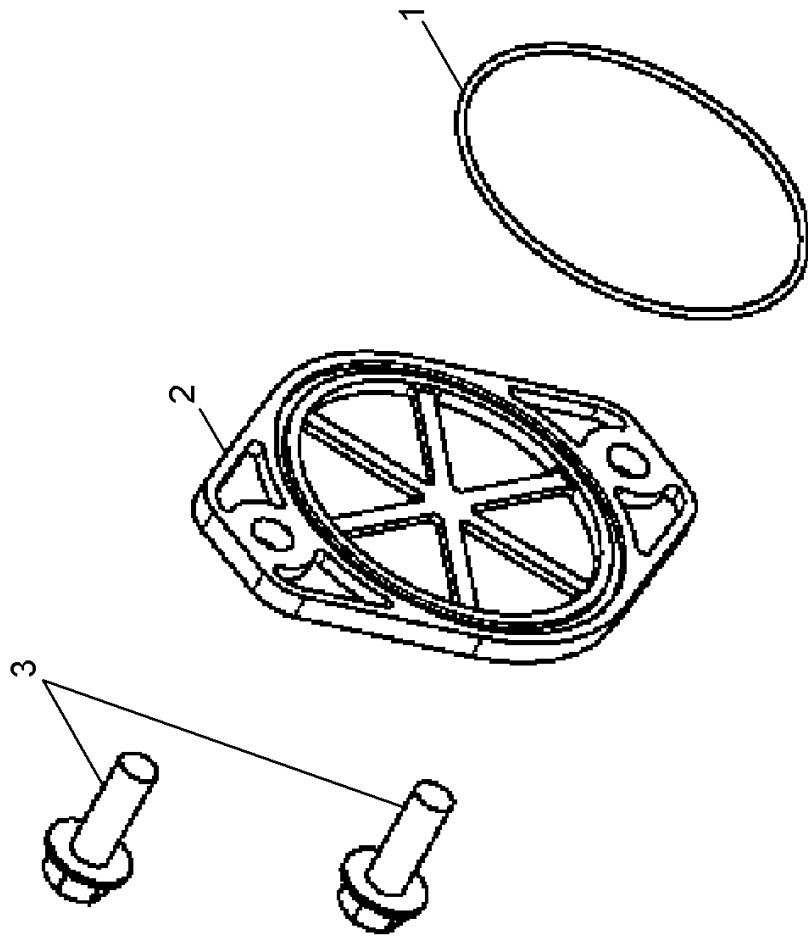

100 CRANKCASE 1)

Pos.	Part No.	Description	Dimension	Quantity	Conditions
1	00 1953 756 0	O-RING	107,62X2,616	1	
2	00 1954 081 0	COVER		1	
3	60 0502 277 6	SCREW	M12X35	2	
1)	machine no.				+ 0 + K5500201 DRIVING COVER

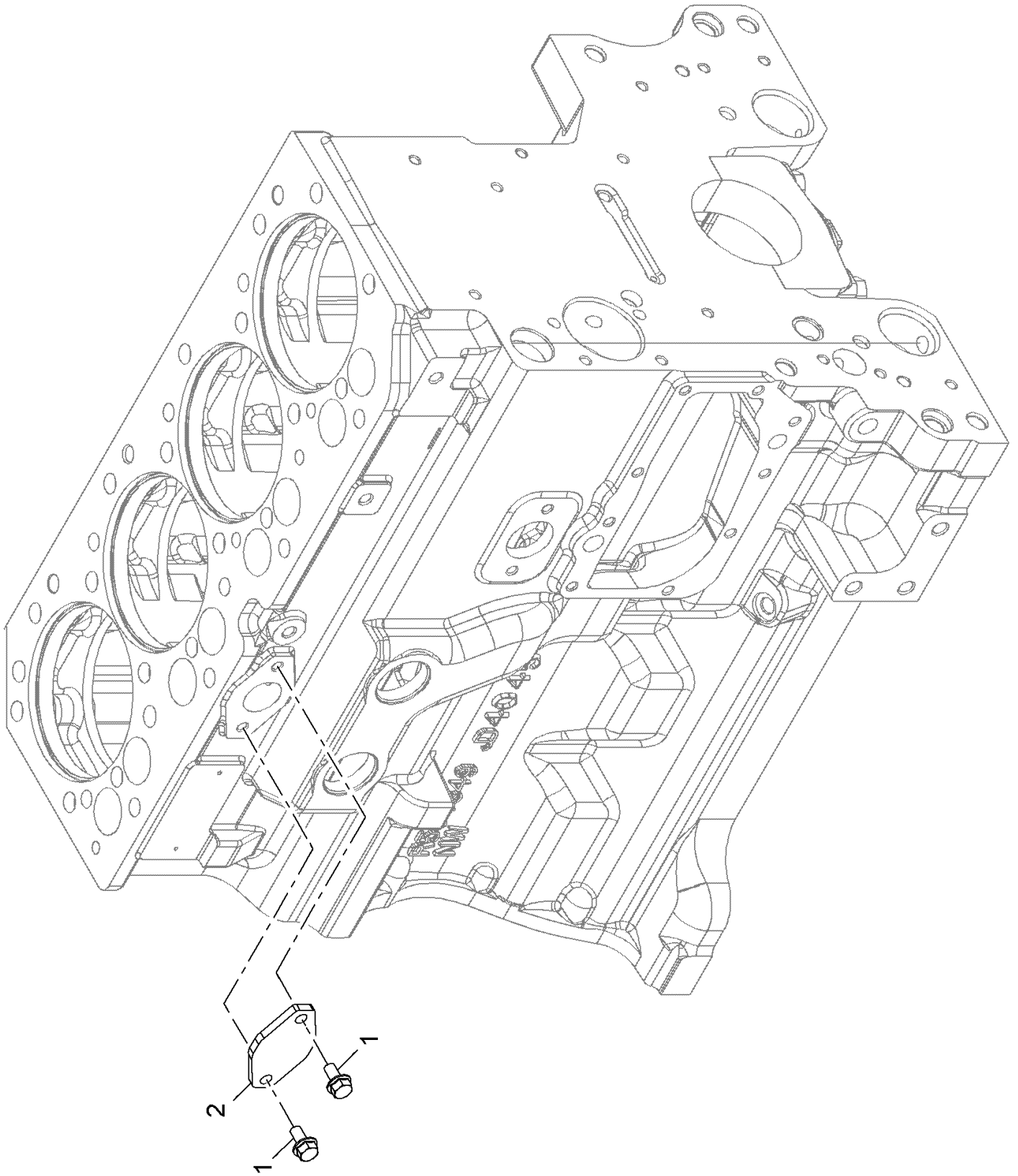

100 CRANKCASE 1)

Pos.	Part No.	Description	Dimension	Quantity	Conditions
1	60 0502 662 3	SCREW		2	
2	60 0502 662 2	PLATE		1	
1)	machine no.				+ 0 + K5500201 COVER

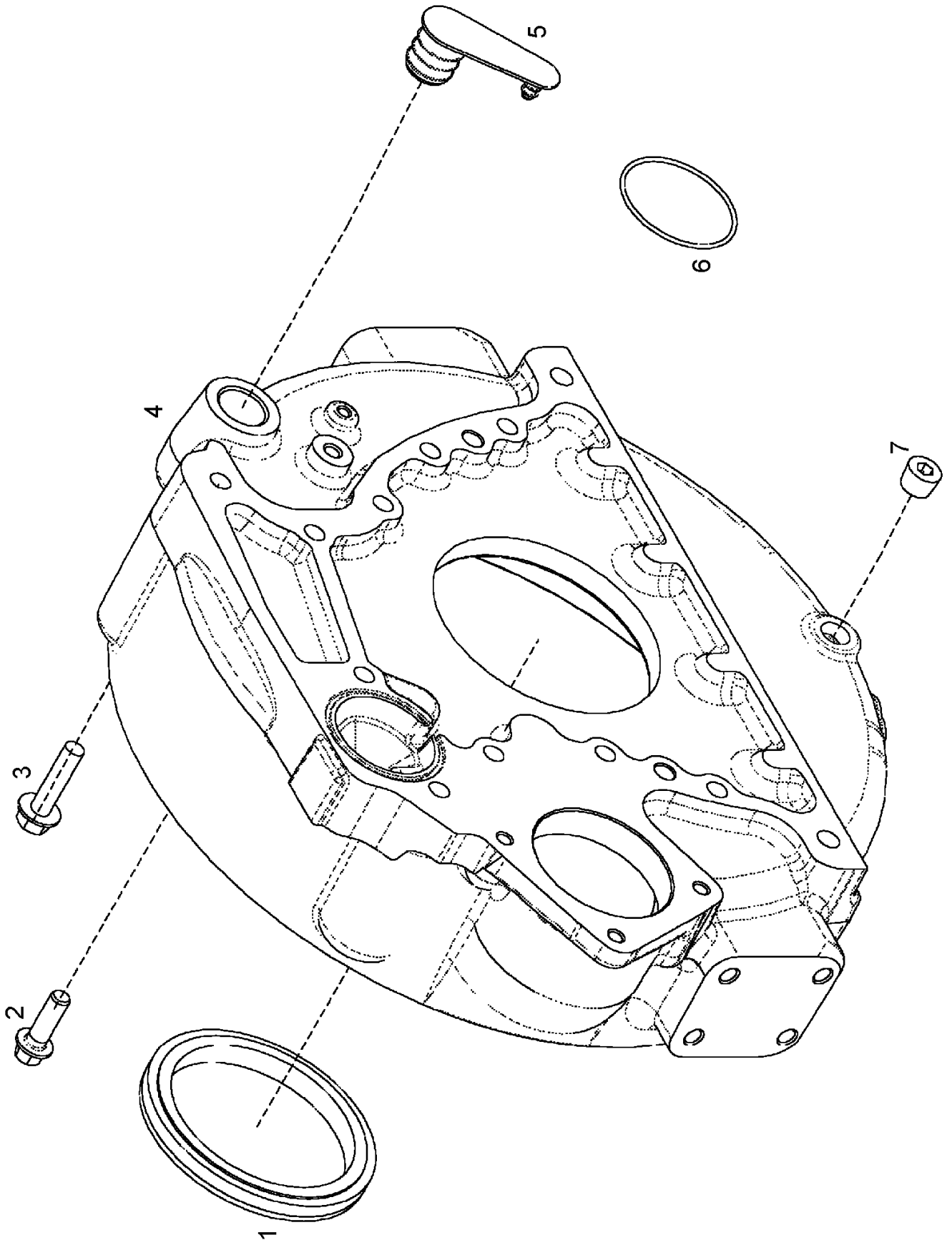

140 FLYWHEEL HOUSING 1)

Pos.	Part No.	Description	Dimension	Quantity	Conditions
1	00 1145 360 0	LIP SEAL		1	
2	60 0502 625 8	SCREW	12 X 1,75 -37 - M12X40	8	
3	00 1147 755 0	SCREW	M12X50	4	
4	00 1953 173 0	SCHWUNGRADGEHAEUSE		1	
5	00 1953 174 0	PLUG		1	
6	00 1953 755 0	O-RING	69,25X2,616	1	
1)	machine no.		+ 0 + K5500201 FLYWHEEL HOUSING		

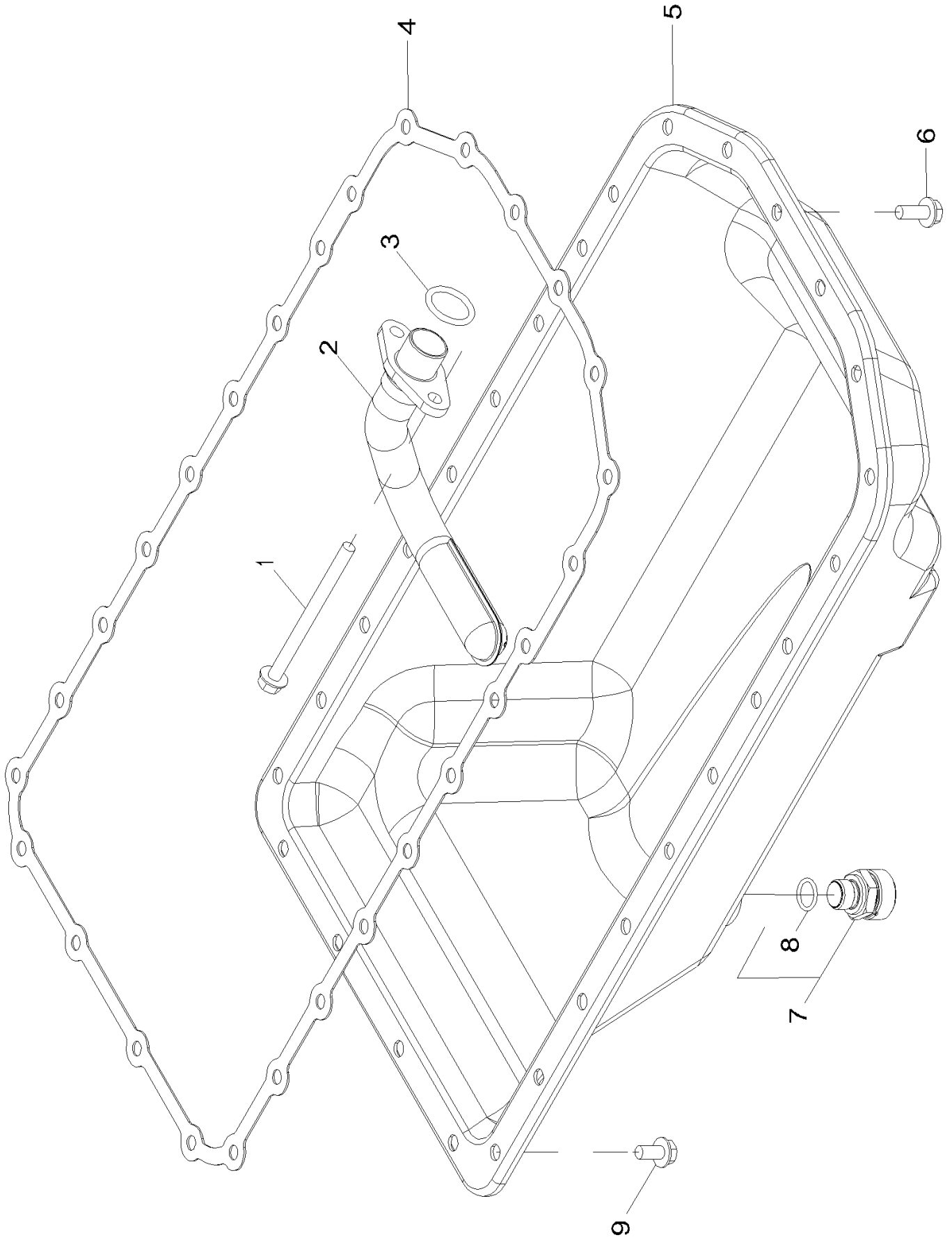

160 OIL PAN 1)

Pos.	Part No.	Description	Dimension	Quantity	Conditions
1	00 1146 050 0	SCREW		2	
2	60 0502 897 9	STRAINER		1	
3	60 0501 334 6	O-RING		1	
4	00 1166 771 0	FLAT SEAL		1	
5	00 1953 175 0	OIL SUMP		1	
7	00 1952 306 0	DRAIN VALVE		1	
8	60 0502 160 8	O-RING	15,3X2,2-N	1	
<hr/>					
1)	machine no.		+ 0		
			+ K5500201		
			OIL SUMP		

Thank you so much for reading.
Please click the “Buy Now!”
button below to download the
complete manual.



After you pay.

You can download the most
perfect and complete manual in
the world immediately.

Our support email:

ebooklibonline@outlook.com