

-2017 00 0601

2017 00 0602-

**010 COMPLETE ENGINE 1)**

Pos.	Part No.	Description	Dimension	Quantity	Conditions
1	<b>00 1955 024 0</b>	TORSION DAMPER		1	
1	<b>00 1955 024 0</b>	TORSION DAMPER		1	
2	<b>00 1955 691 0</b>	RING	COUPLING ASSY D.ENG.	1	
3	<b>00 0469 980 0</b>	ZYLINDERSCHR NID M IN-6KT	M10X30	12	
4	<b>00 0224 198 0</b>	HEX.HEAD BOLT	M10X30-B=15	6	
131	<b>ERS05</b>	NO LONGER AVAILABLE		1	
	<b>00 0215 098 0</b>	SOCKET HEAD SCREW	M10X 40	6	

<b>1)</b>	<b>machine no.</b>	+ 0
		+ K5800100
		+ K5800201
		+ K5800202
		+ K5800203
		+ K5800204
		+ K5800205
		+ K5800206
		+ K5800207
		+ K5800208

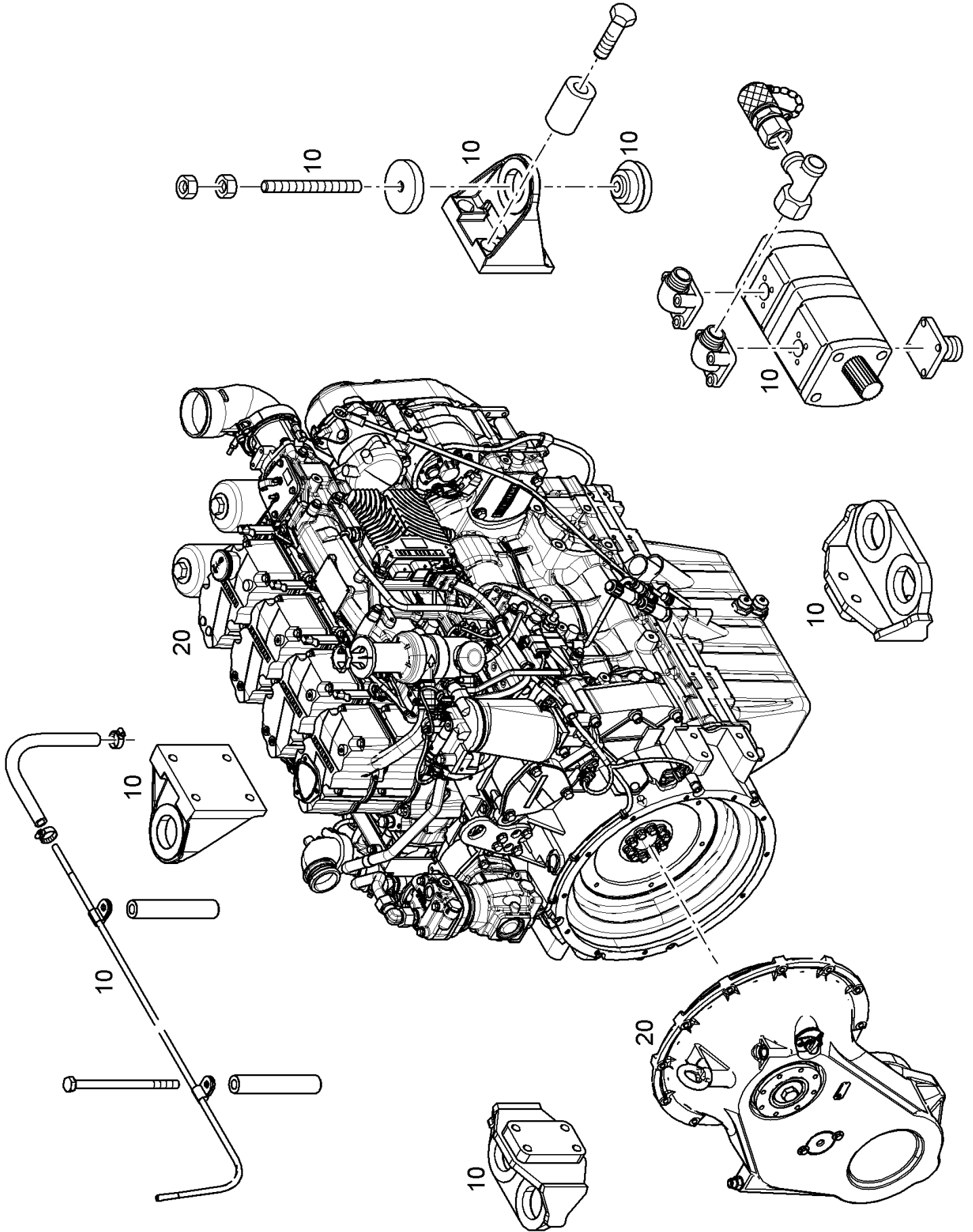

**010 COMPLETE ENGINE 1)**

Pos.	Part No.	Description	Dimension	Quantity	Conditions
10		ANBAUTEILE MOTOR		1	2)
20	<b>ERS08</b>	ORDER SINGLE PARTS		1	
<b>1)</b>	<b>machine no.</b>				
		+ 0			
		+ K5800100			
		+ K5800201			
		+ K5800202			
		+ K5800203			
		+ K5800204			
		+ K5800205			
		+ K5800206			
		+ K5800207			
		+ K5800208			
<b>2)</b>	<b>Remarks</b>				
					-> BGZ 09 10 100 -> Drawing no.: 303179

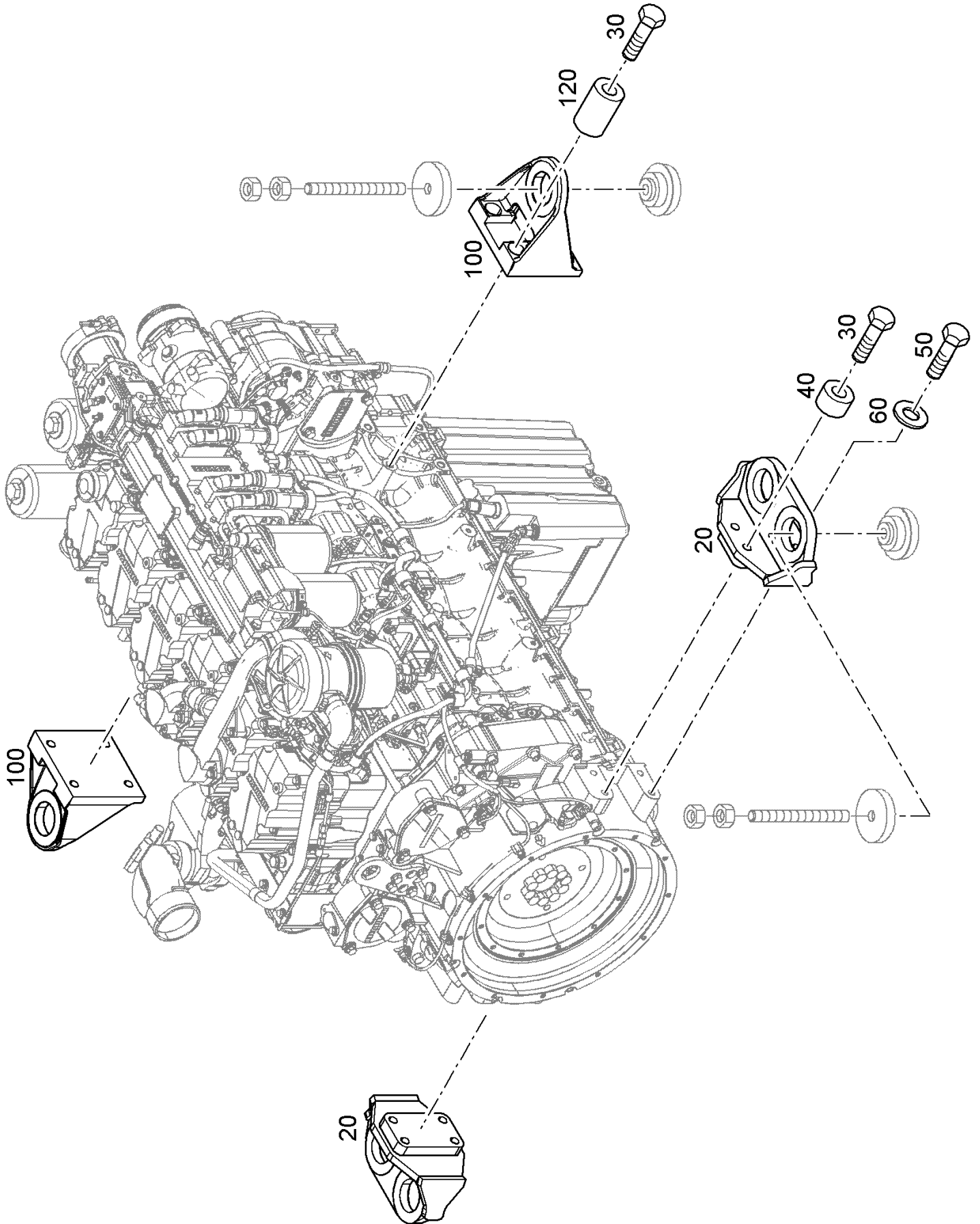

**010 COMPLETE ENGINE 1)**

Pos.	Part No.	Description	Dimension	Quantity	Conditions
20	<b>00 1950 599 0</b>	MOTORKONSOLE VORNE		2	
30	<b>00 0665 955 1</b>	SCREW	M16X80	12	
40	<b>00 1952 091 0</b>	DEHNHUELSE		4	
50	<b>00 0215 613 0</b>	HEXAGON HEAD BOLT	M16X70	4	
60	<b>00 0342 473 0</b>	LOCK WASHER	NL16SP - 17X30,7X3,4	4	
100	<b>00 1950 698 0</b>	SUPPORT BRACKET	DIESELMOTOR	2	
120	<b>00 1952 102 0</b>	DEHNHUELSE	17X30X40	8	

<b>1)</b>	<b>machine no.</b>	+ 0
		+ K5800100
		+ K5800201
		+ K5800202
		+ K5800203
		+ K5800204
		+ K5800205
		+ K5800206
		+ K5800207
		+ K5800208



**010 COMPLETE ENGINE 1)**

Pos.	Part No.	Description	Dimension	Quantity	Conditions
130	<b>00 1951 923 1</b>	DOPPELZAHNRADPUMPE		1	
140	<b>00 0224 060 0</b>	ZYLINDERSCHR IN-6KT	M10X190	2	
150	<b>00 0217 165 1</b>	LOCK WASHER	NL10 - 10,7X16,6X2,5	2	
160	<b>00 0674 722 0</b>	WINK-FLANSCH-STUTZEN MIT ZUBEHOER	WFS 16 S-35-OMS	2	
170	<b>00 0249 845 0</b>	ELBOW	SWOE-S16	1	
180	<b>00 0249 877 0</b>	T-UNION, ADJUSTM.	SWORT-S16	1	
190	<b>00 1951 981 0</b>	MEASUREMENT NOZZLE	1620 - S16 (DKO M24X1,5)	1	
200	<b>00 0213 601 0</b>	FLANGE SUPPORT	GFS-L28-LK40-L34, 5-OMD	1	
460	<b>00 0224 031 0</b>	STRAIGHT MALE CONNECTOR	SDS-L22XM33X2-TYPE 3 E		
465	<b>00 0249 802 0</b>	SOCKET	RDSW-L22-L12	1	
470	<b>00 1952 128 0</b>	HOSE FITTING	SWE45 L22X19 (N45-M30X2)	1	
471	<b>00 1952 138 0</b>	HOSE FITTING	SWS L22 X 19 (M30X2)	1	
475	<b>00 0597 486 1</b>	IMPACT CONNECTION	SWE45-L15-12 (N45-M22X1,	1	
480	<b>ERS05</b>	NO LONGER AVAILABLE		1	
490	<b>00 1954 001 0</b>	SPACER SLEEVE	9X18X120	2	
500	<b>00 1991 918 0</b>	HOLDER CLAMP	D1-8X20	2	
510	<b>00 0244 238 0</b>	HEXAGON HEAD BOLT	M 8X140	2	
520	<b>00 0249 327 0</b>	LOCK WASHER	VS 8 -8,4X13X1,1,1X1,72		
530	<b>00 0224 095 0</b>	FLAT WASHER	8 -8,4X16X1,6	2	
550	<b>77 0004 585 5</b>	HOSE CLAMP	A 10-16X7,5 C6	1	
555	<b>00 0233 015 0</b>	HOSE CLAMP	B1-18X12	2	
690	<b>00 0217 394 0</b>	SCREW-IN FITTING	SDS-L15XM26X1, 5-TYPE E	1	
700	<b>00 0249 836 0</b>	ANGULAR MALE CONNECTOR	SWOE-L15	1	

<b>1)</b>	<b>machine no.</b>	+ 0
		+ K5800100
		+ K5800201
		+ K5800202
		+ K5800203
		+ K5800204
		+ K5800205
		+ K5800206
		+ K5800207
		+ K5800208



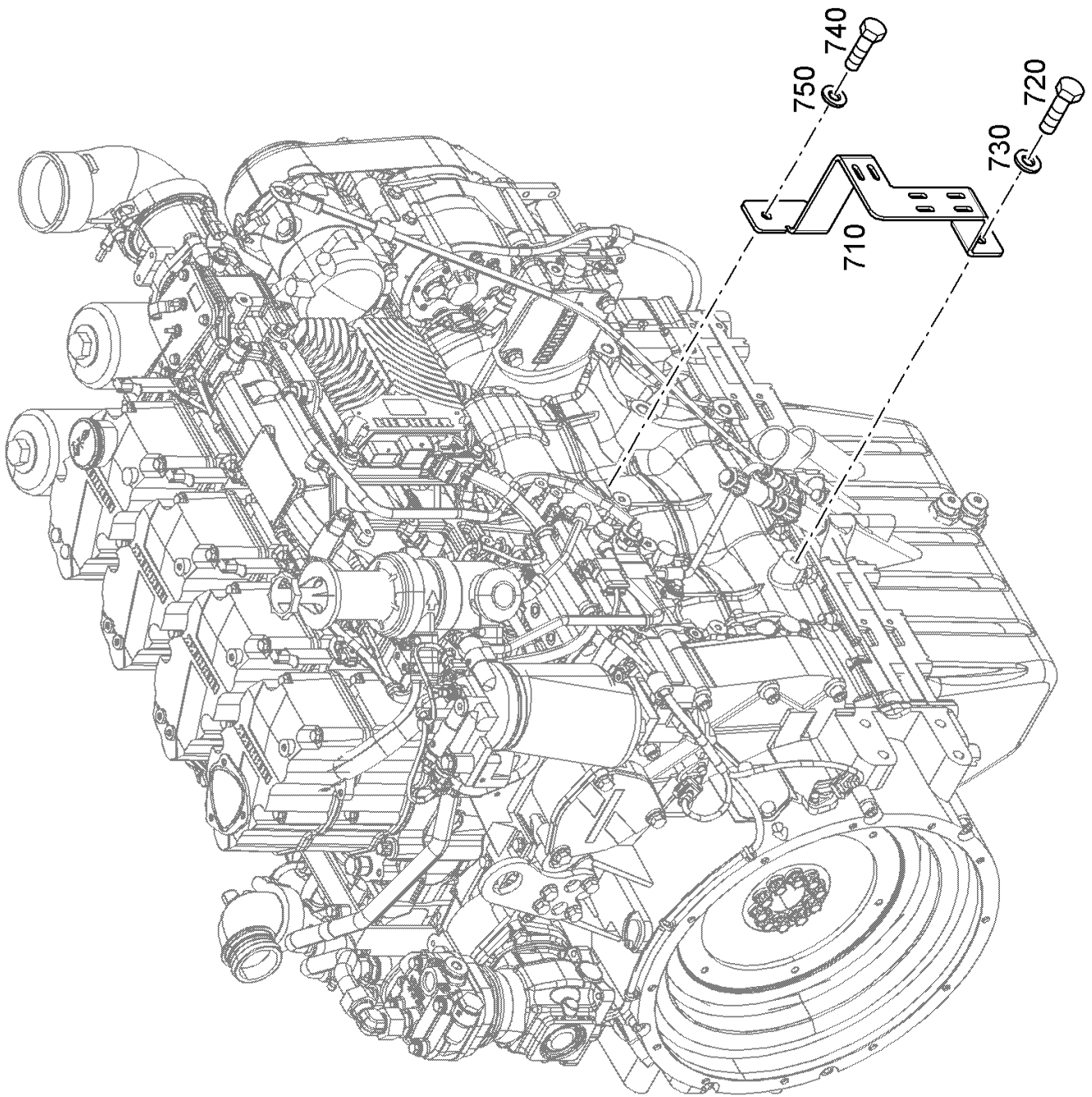

**010 COMPLETE ENGINE 1)**

<b>Pos.</b>	<b>Part No.</b>	<b>Description</b>	<b>Dimension</b>	<b>Quantity</b>	<b>Conditions</b>
710	<b>00 1955 005 0</b>	CABLE HOLDER	4X115X194	1	
720	<b>00 0233 414 0</b>	HEXAGON HEAD BOLT	M10X20	1	
730	<b>00 0249 156 0</b>	WASHER	10,5-10,5X28X4	1	
740	<b>00 0236 200 0</b>	HEXAGON HEAD BOLT	M8X20	1	
750	<b>00 0106 395 0</b>	WASHER	8,4	1	

**1) machine no.**

+ 0  
+ K5800100  
+ K5800201  
+ K5800202  
+ K5800203  
+ K5800204  
+ K5800205  
+ K5800206  
+ K5800207  
+ K5800208

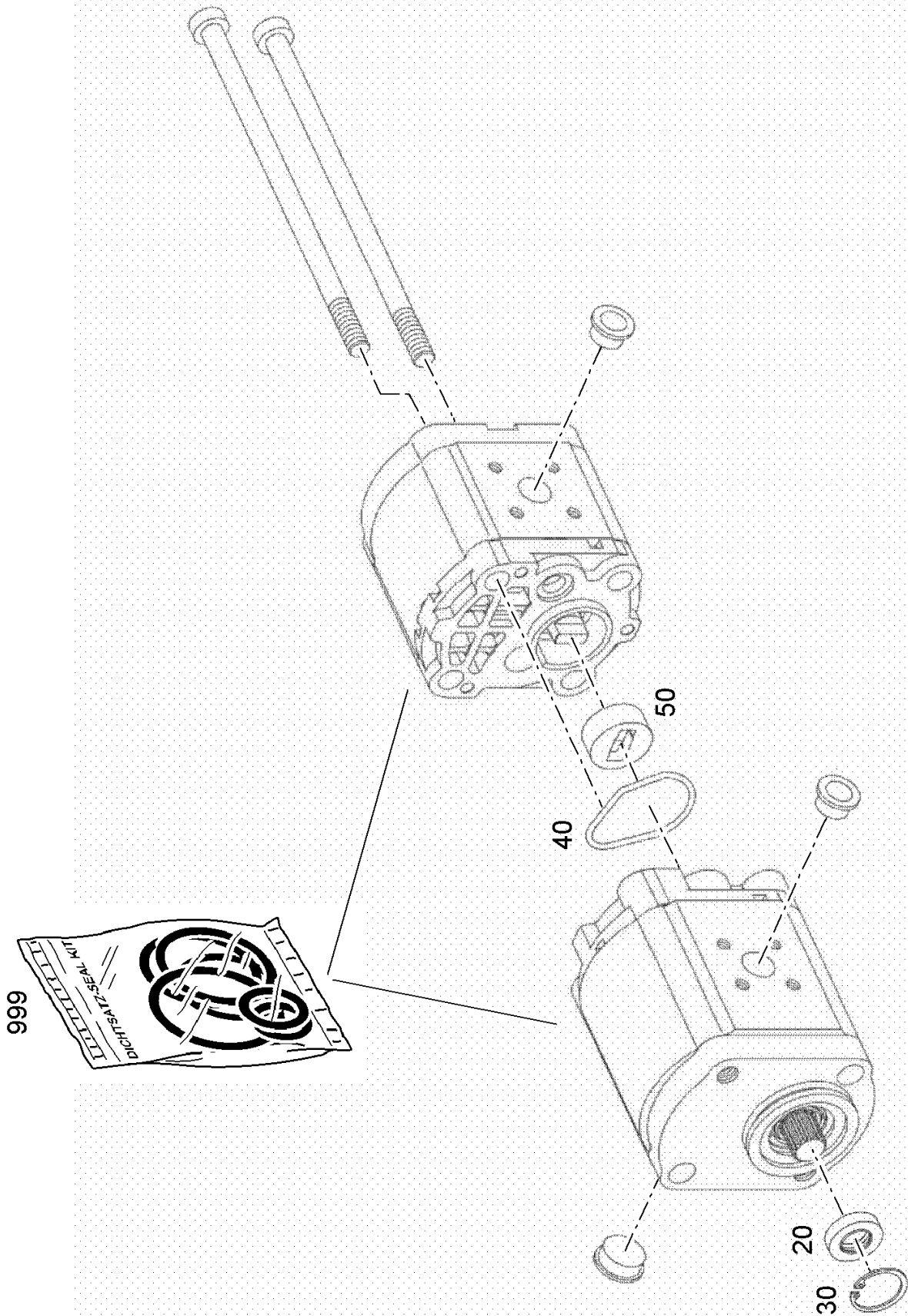

**010 COMPLETE ENGINE 1)**

Pos.	Part No.	Description	Dimension	Quantity	Conditions
30	<b>00 0125 116 0</b>	CIRCLIP	30X1,2	1	
50	<b>00 1951 977 0</b>	COUPLER		1	

**1) machine no.**

+ 0  
+ K5800100  
+ K5800201  
+ K5800202  
+ K5800203  
+ K5800204  
+ K5800205  
+ K5800206  
+ K5800207  
+ K5800208

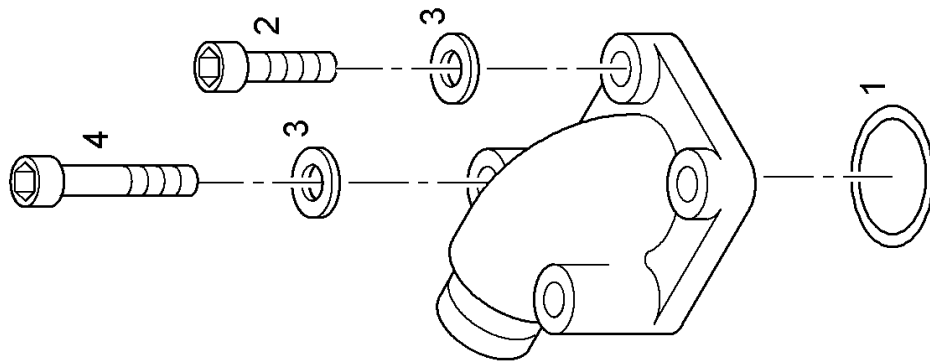

**010 COMPLETE ENGINE 1)**

Pos.	Part No.	Description	Dimension	Quantity	Conditions
1	<b>00 1301 341 0</b>	O-RING	20X2,5-N	1	
2	<b>00 0238 352 0</b>	SOCKET HEAD SCREW	M 6X 22	2	
3	<b>00 0320 190 0</b>	WASHER	M06	4	
4	<b>00 0242 219 1</b>	SOCKET HEAD SCREW	M6X40	2	

<b>1)</b>	<b>machine no.</b>	+ 0
		+ K5800100
		+ K5800201
		+ K5800202
		+ K5800203
		+ K5800204
		+ K5800205
		+ K5800206
		+ K5800207
		+ K5800208

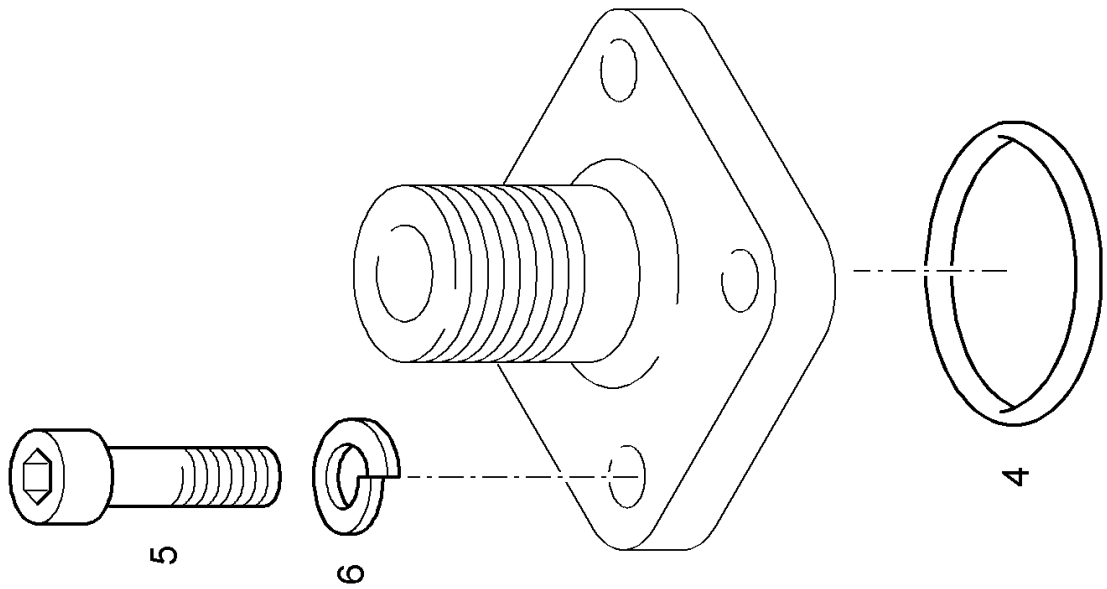

Thank you so much for reading.  
Please click the “Buy Now!”  
button below to download the  
complete manual.



After you pay.

You can download the most  
perfect and complete manual in  
the world immediately.

Our support email:

[ebooklibonline@outlook.com](mailto:ebooklibonline@outlook.com)