

100 CRANKCASE 1)

Pos.	Part No.	Description	Dimension	Quantity	Conditions
1		KURBELGEHAEUSE VORM.		1	2)
2	00 0238 023 0	LOCKING COVER	A 32	4	
3	00 1301 654 0	LOCKING COVER	A 45	7	
14	00 1951 894 0	SEALING PLUG		14	
80		CYLINDER		4	3)
104	00 1994 261 0	GLUE	50 ML LOCTITE 648	1	
1)	machine no.				
				+ 0	
				+ K5900201	
				+ K5900202	
				+ K5900203	
				+ K5900204	
				+ K5900205	
				+ K5900206	
				CRANKCASE CPL. WITH CYLINDER	
2)	Remarks				-> BGZ 01 10 100 -> Drawing no.: E02582
3)	Remarks				-> BGZ 01 15 100 -> Drawing no.: 129553

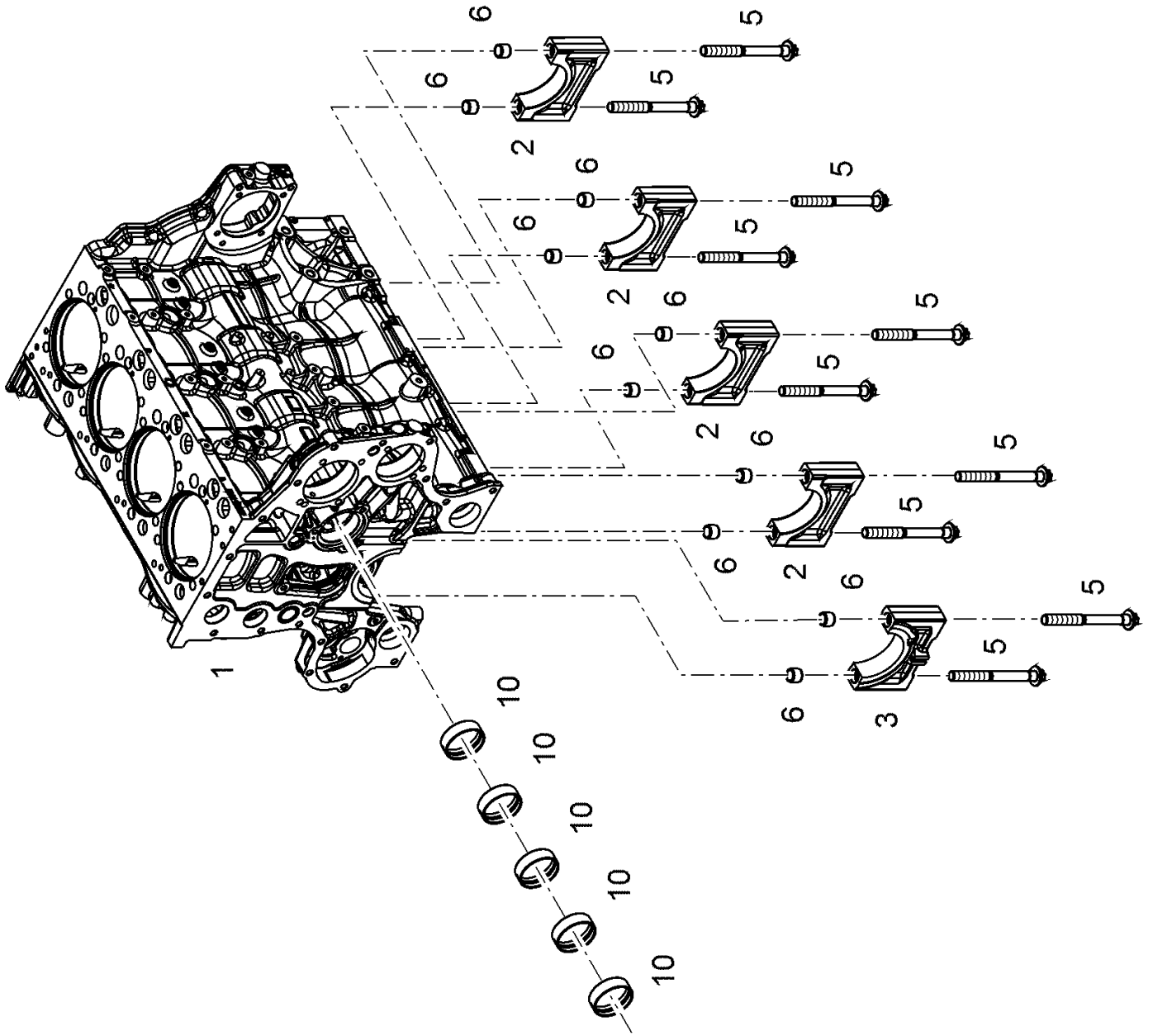

100 CRANKCASE 1)

Pos.	Part No.	Description	Dimension	Quantity	Conditions
1		CYL.-CRANKCASE		1	
2		HAUPTLAGERDECKEL		4	
3		PASSLAGERDECKEL		1	
5	00 1951 490 0	SECHSRUNDSCHRAUBE	M18X2X181X80	10	
6	00 1951 996 0	PASSHUELSE	15,5X19,5X24	10	
10	00 1951 886 0	NOCKENWELLENBUCHSE		5	

1)	machine no.	+ 0
		+ K5900201
		+ K5900202
		+ K5900203
		+ K5900204
		+ K5900205
		+ K5900206
		CRANKCASE PRE-ASSY.

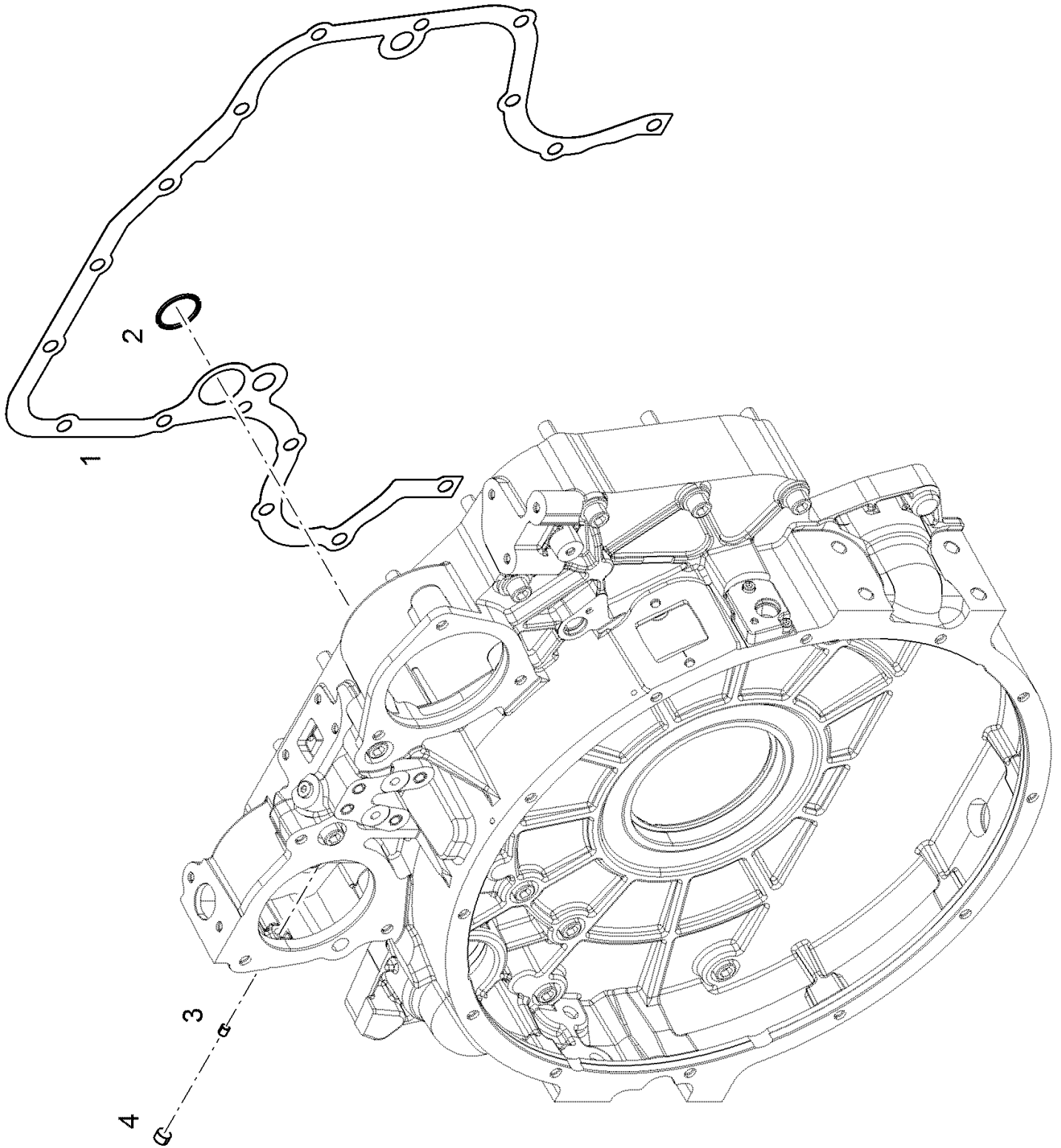

140 FLYWHEEL HOUSING 1)

Pos.	Part No.	Description	Dimension	Quantity	Conditions
1	00 1951 494 0	GASKET		1	
2	00 0216 866 1	O-RING	126A-34,59X2,62 -N	1	
4	00 1951 894 0	SEALING PLUG		1	

1) machine no.

+ 0
+ K5900201
+ K5900202
+ K5900203
+ K5900204
+ K5900205
+ K5900206
SEAL KIT FLYWHEEL HOUSING

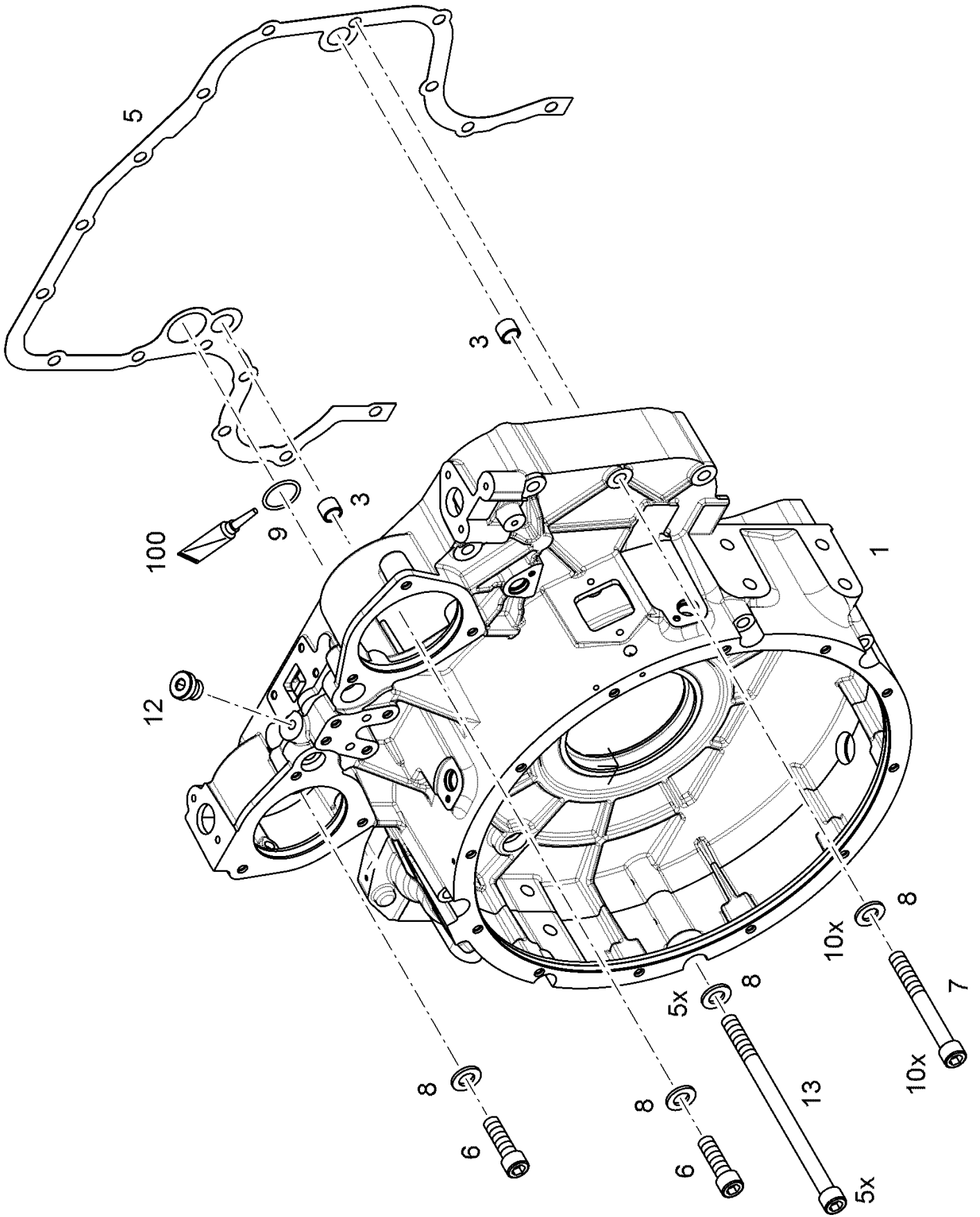

140 FLYWHEEL HOUSING 1)

Pos.	Part No.	Description	Dimension	Quantity	Conditions
1	00 1951 394 0	SCHWUNGRADGEHAEUSE VORM.		1	
3	00 1952 041 0	PASSHUELSE	16X20X20	2	
5	00 1951 494 0	GASKET		1	
6	00 0233 213 0	SOCKET HEAD SCREW	M12X 40	2	
7	00 0223 498 0	ZYLINDERSCHR IN-6KT	M12X100	10	
8	00 0213 801 0	FLAT WASHER	12-13X24X2,5	17	
9	00 0216 866 1	O-RING	126A-34,59X2,62 -N	1	
13	00 0224 063 0	ZYLINDERSCHR IN-6KT	M12X210	5	
100	ERS06	NOT DELIVERABLE AS A SINGLE PART		1	

1) machine no.

+ 0
+ K5900201
+ K5900202
+ K5900203
+ K5900204
+ K5900205
+ K5900206
FLYWHEEL HOUSING MOUNTING

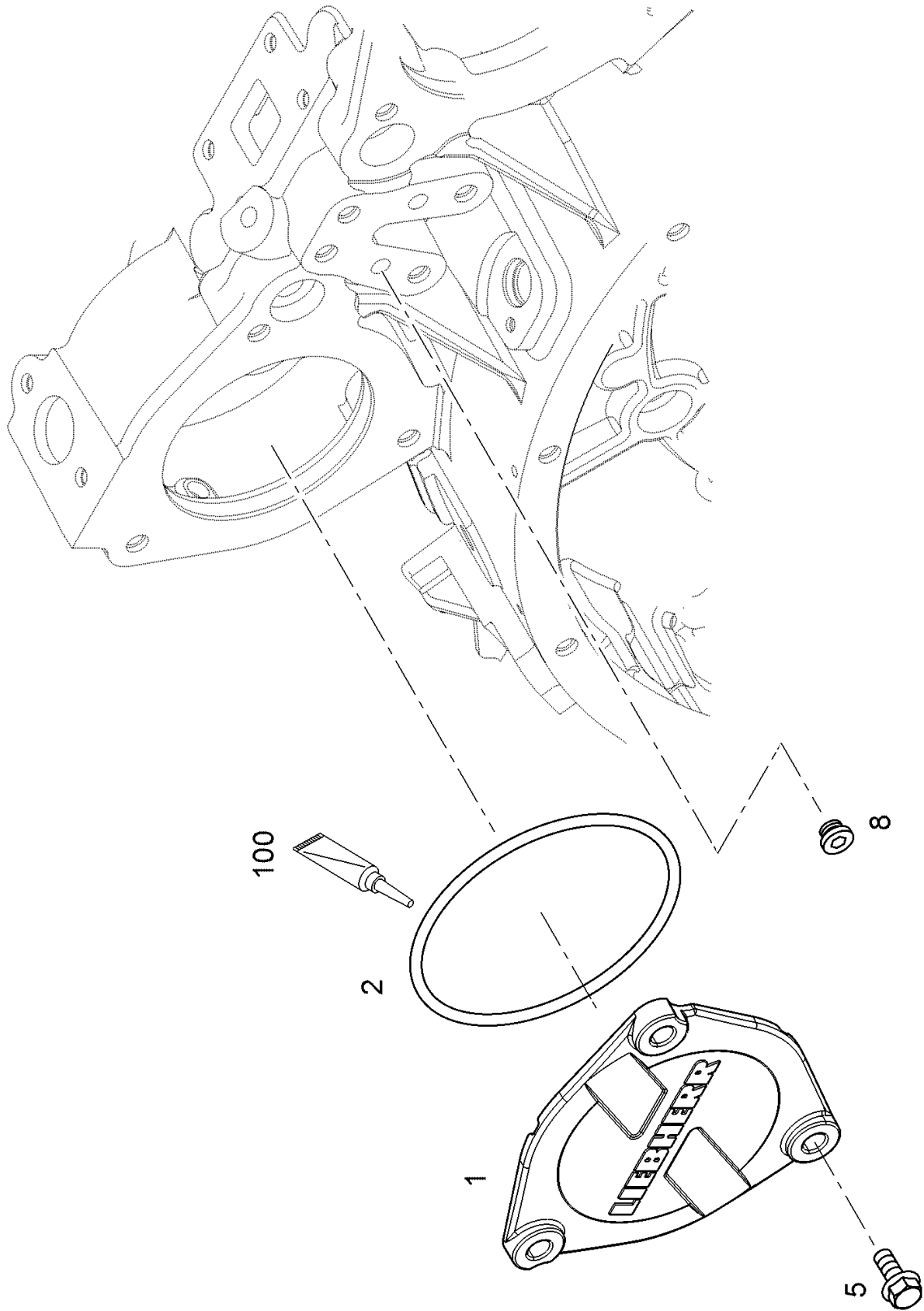

140 FLYWHEEL HOUSING 1)

Pos.	Part No.	Description	Dimension	Quantity	Conditions
1	00 1951 802 0	COVER		1	
2	00 0224 278 0	O-RING	243A-104,37X3,53 -N	1	
5	00 0217 111 0	BOLT-FLANGED HD	M10X25	3	
100	ERS06	NOT DELIVERABLE AS A SINGLE PART		1	

1)	machine no.	+ 0			
		+ K5900201			
		+ K5900202			
		+ K5900203			
		+ K5900204			
		+ K5900205			
		+ K5900206			
		LOCKING PIECES			

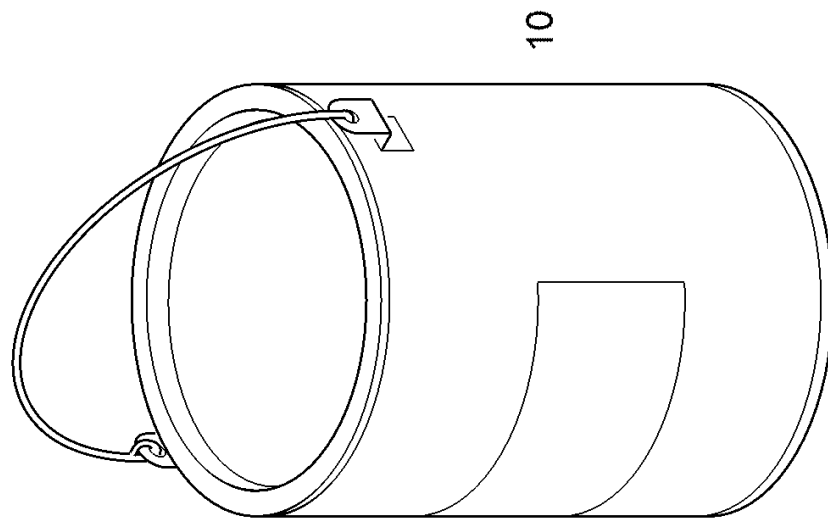

140 FLYWHEEL HOUSING 1)

Pos.	Part No.	Description	Dimension	Quantity	Conditions
10	ERS06	NOT DELIVERABLE AS A SINGLE PART		1	
1)	machine no.				
				+ 0	
				+ K5900201	
				+ K5900202	
				+ K5900203	
				+ K5900204	
				+ K5900205	
				+ K5900206	
				LOCKING PIECES	

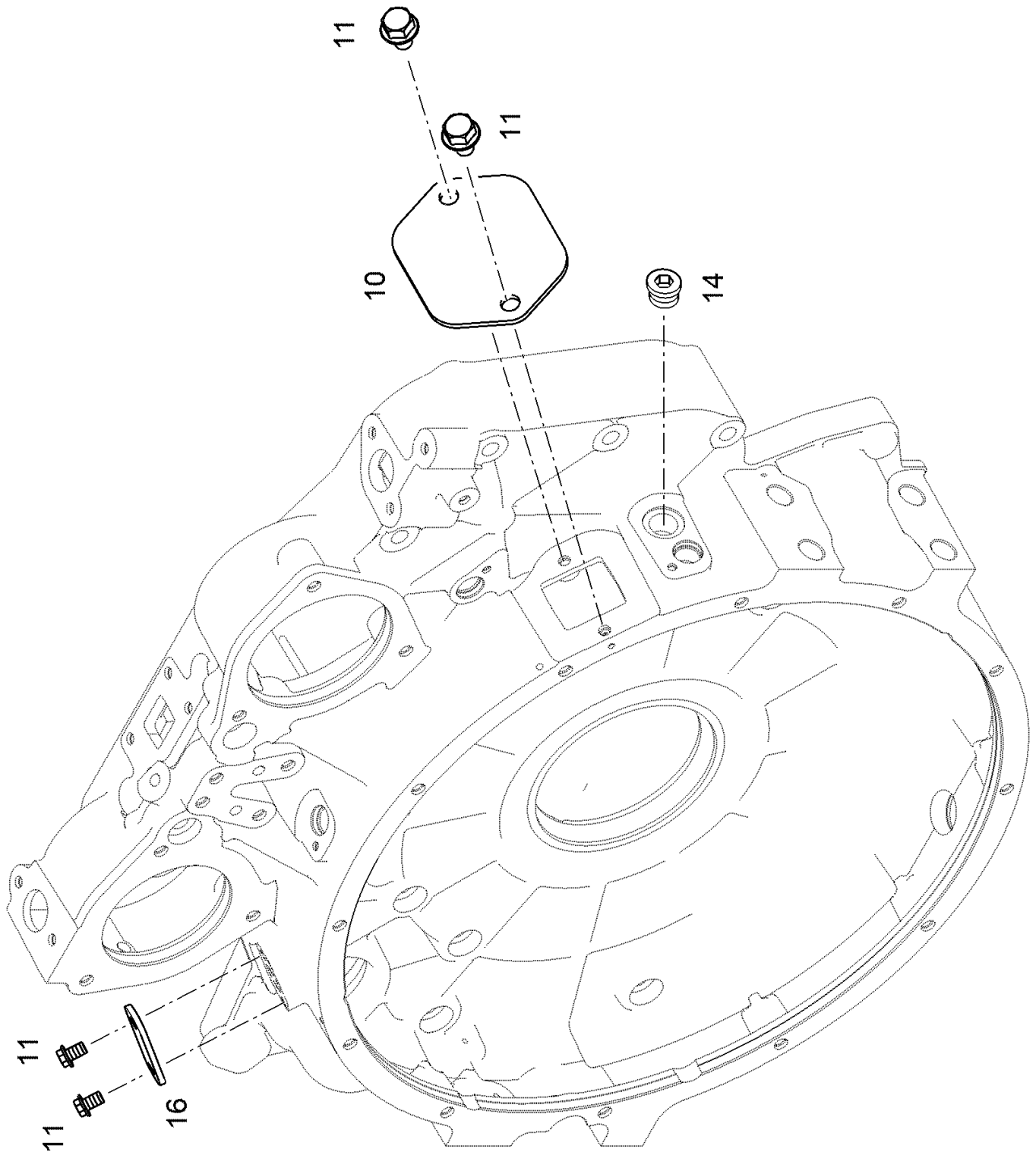

140 FLYWHEEL HOUSING 1)

Pos.	Part No.	Description	Dimension	Quantity	Conditions
10	00 1952 009 0	COVER		1	
11	00 0216 909 0	HEXAGON HEAD BOLT	M 8X16	4	
16	00 1952 520 0	PLATE		1	

1)	machine no.	+ 0			
		+ K5900201			
		+ K5900202			
		+ K5900203			
		+ K5900204			
		+ K5900205			
		+ K5900206			
		LOCKING PIECES			

Thank you so much for reading.
Please click the “Buy Now!”
button below to download the
complete manual.



After you pay.

You can download the most
perfect and complete manual in
the world immediately.

Our support email:

ebooklibonline@outlook.com