

Section: ENGINE  
WATER COOLING

Fig.	P/n	QTY	Name
------	-----	-----	------

Notes:  
[Agrotron 200]

2	0.013.2227.0	1	spacer
3	0.013.2400.4	1	fan
4	2.0432.023.7	4	stud bolt m 8 p. x 90
5	2.1470.004.2	4	lock washer 8
6	2.1011.405.2	4	nut m 8 p.1
7	2.4119.180.0	2	belt AV 12.7x1645 mm

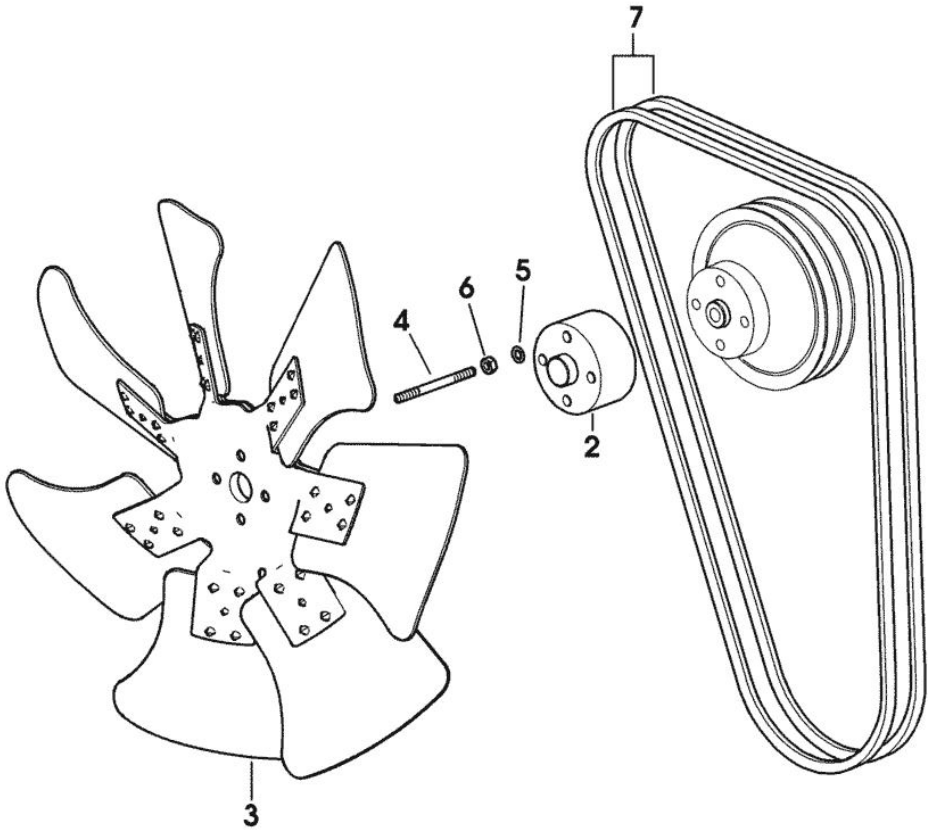

9\_M3919\_02\_0\_0

Section: ENGINE

**PARTS SET - ENGINE MOUNTING**

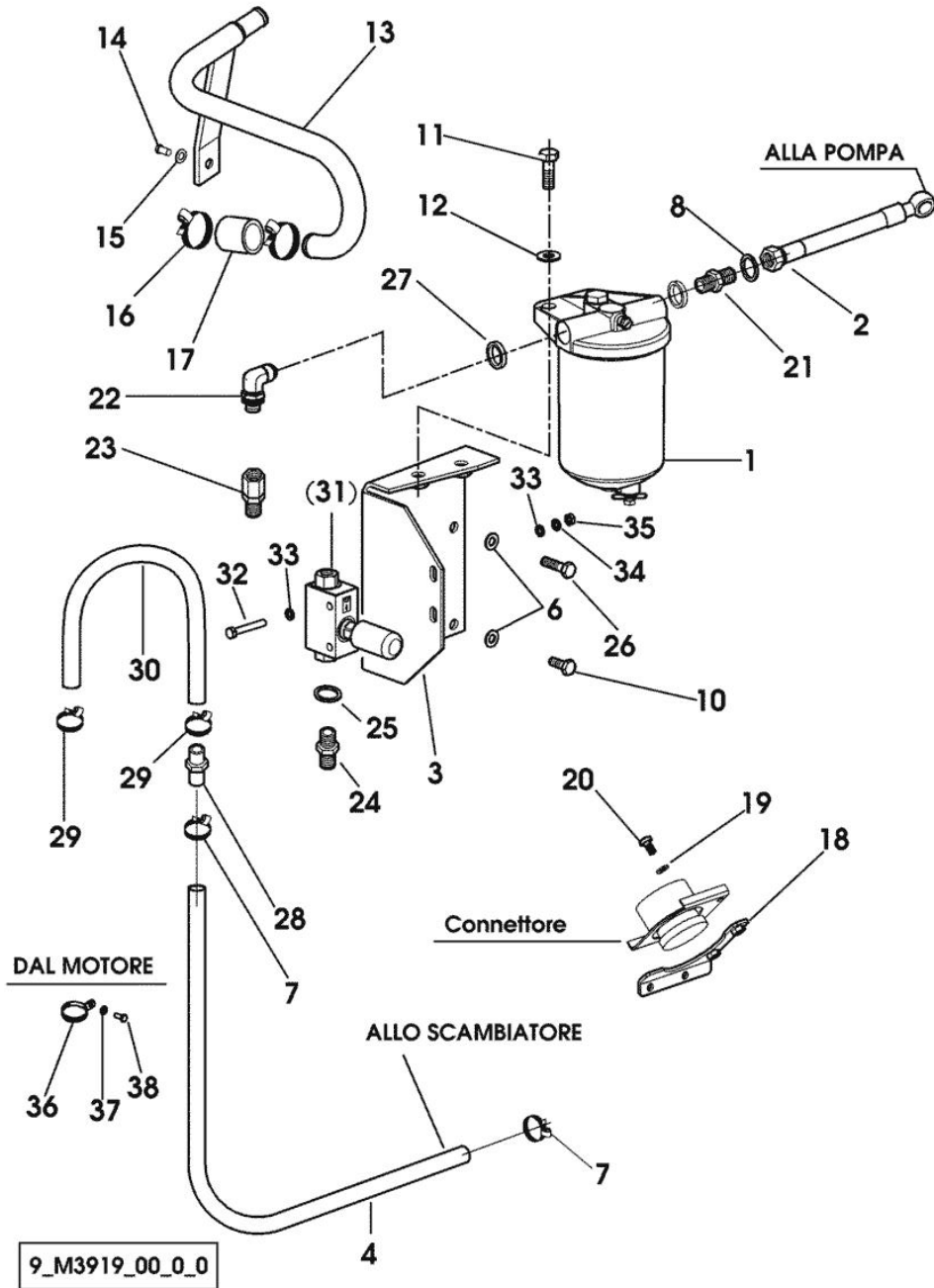

Fig.	P/n	QTY	Name
------	-----	-----	------

**Notes:**

[Agrotron 200]

1	02111290	1	filter COMPONENT PARTS SEE COMPONENTS LIST ☞ 02111290
2	0.013.2429.3/10	1	tube
3	0.013.4079.3/10	1	bracket
4	0.012.6450.0		tube Ø mm 13/20
6	2.1310.004.2	2	flat washer 8.4x17
7	2.6851.001.0	2	clamp Ø 16/25
8	2.1560.012.0	1	gasket 16.2 x 22
10	2.0112.207.2	1	screw m 8 p 1.25 x 20
11	2.0112.311.2	2	screw m 10 p.1.5 x 30
12	2.1310.006.2	2	flat washer 10.5x21
13	0.013.2405.3	1	tube
14	2.0112.005.2	1	screw m 6 p.1 x 16
15	2.1310.002.3	1	flat washer 6.4 x 12 x 1.6
16	2.6851.002.0	2	clamp Ø 20/32
17	01175630	1	sleeve 22x29x71
18	0.013.3517.3	1	bracket
19	2.1310.002.2	2	flat washer 6.4x12.5
20	2.0332.404.2	2	screw m 6 p.1 x 12
21	2.3249.088.2	1	pipe fitting M16x1,5-7/8" 14 JIC
22	2.3249.101.2	1	pipe fitting m 16 p1.5
23	2.3339.877.2	1	pipe fitting m 18 p.1.5 3/4" - 16 JIC
24	2.3261.010.2	1	pipe fitting m 18 p.1.5 - 7/8" 14
25	2.1560.014.0	1	washer 18.2 x 24
26	2.0112.211.2	1	screw m 8 p.1.25 x 30
27	2.1569.154.0	1	gasket 16.2x22x6
28	2.3249.512.2	1	pipe fitting
29	2.6851.001.0	2	clamp Ø 16/25
30	0.012.6449.0		tube
31	0.013.4244.4	1	pump 3030 <- X Agrotron 200
32	2.0112.017.2	2	screw m 6 p.1x45
33	2.1310.002.2	4	flat washer 6.4x12.5
34	2.1470.002.2	2	lock washer 6
35	2.1011.103.2	2	nut m 6 p.1
36	2.6839.051.0	1	clamp 20/20
37	2.1470.004.2	1	lock washer 8
38	2.0112.204.2	1	screw m 8 p.1.25x14

Section: ENGINE  
**INTERCOOLER**

Fig.	P/n	QTY	Name
------	-----	-----	------

Notes:  
[Agrotрон 200]

1	0.013.3592.2/10	1	radiator
2	0.013.3799.0	1	tube
3	0.013.1167.0/10	1	tube
4	0.013.1413.0	2	sleeve
7	2.6851.008.0	1	clamp Ø 70/90
9	2.6859.110.0	2	clamp
10	0.013.1414.0	2	sleeve
11	04209073	1	sleeve
12	2.0312.104.2	2	screw m 6 p.1 x 16
13	2.1312.003.2	4	washer 6
14	2.0112.004.2	2	screw m 6 p.1 x 14
15	01180295	1	gasket
16	2.6859.111.0	6	clamp Ø 80-85
17	2.1310.002.2	2	flat washer 6.4x12.5
18	2.0112.003.2	2	screw m 6 p.1 x 12

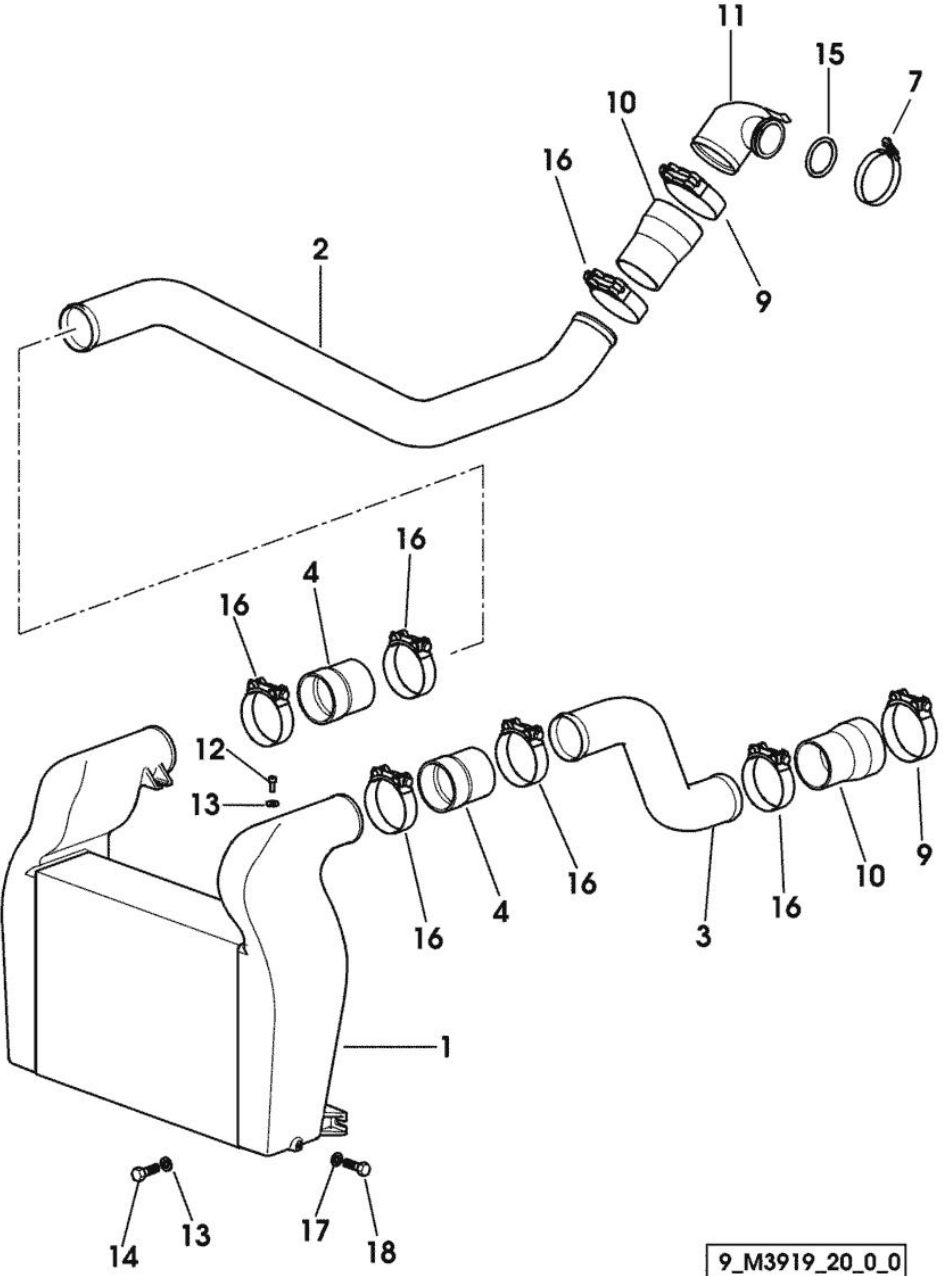

9\_M3919\_20\_0\_0

Section: ENGINE

**AIR COMPRESSOR**

Fig.	P/n	QTY	Name
------	-----	-----	------

Notes:

[Agrotron 200]

1	0.000.0000.1		cannot be supplied
1.1	04428408.4	1	air compressor 229 cm <sup>3</sup> COMPONENT PARTS SEE COMPONENTS LIST ☞ 04428408.4
1.2	04255095.4	1	gear
2	2.1475.003.2	2	washer 10
3	2.0112.309.2	2	screw m 10 p.1.5 x 25
4	04414757	1	pipng
5	01119237	2	pipe union
6	01178939	2	oil seal

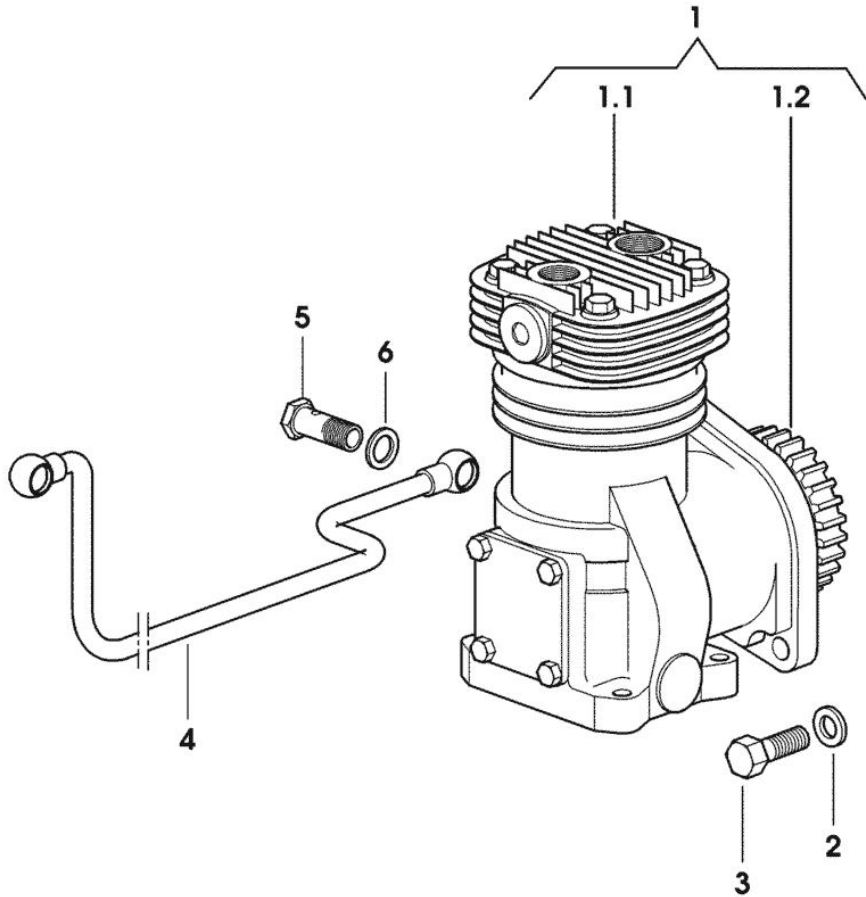

Section: ENGINE

**EXHAUST SILENCER**

9\_B3956\_03\_0\_0

Fig.	P/n	QTY	Name
------	-----	-----	------

Notes:

[Agrotрон 200]

1	0.011.8376.4/20	1	exhaust pipe
2	0.013.1490.4/30	1	silencer
3	0.013.1240.0/20	1	exhaust manifold
4	0.013.1818.4/50	1	guard
5	0.013.1819.0/40	1	guard
6	0.013.1174.0	1	manifold
7	0.011.4901.0	1	gasket
8	0.013.2485.0	1	clamp
9	0.011.4890.0	1	circlip
10	0.011.8217.0/40	1	bracket
11	0.013.1808.3/20	1	bracket
13	2.0112.209.2	2	screw m 8 p 1.25 x 25
14	2.0112.313.2	6	screw m 10 p.1.5 x 35
15	2.0112.327.2	1	screw m 10 p.1.5 x 90
16	2.0312.317.2	2	screw m 10 x 55
17	2.0169.018.2	2	screw m 10 p.1.5x105
18	2.0112.003.2	7	screw m 6 p.1 x 12
19	2.0422.309.2	4	stud bolt m 10 x 35
20	2.1011.106.2	4	nut m 10 p.1.5
21	2.1310.006.2	6	flat washer 10.5x21
22	2.1312.003.2	7	washer 6
23	2.1475.002.2	4	conical washer 8
24	2.1475.003.2	9	washer 10
25	2.1480.015.2	4	washer 10
26	2.1312.004.2	2	washer 8x24x2
27	2.0112.204.2	2	screw m 8 p.1.25x14
28	0.013.3146.0/10	1	guard
29	0.013.4440.2/10	1	bracket
30	0.013.4437.0	1	bracket
31	2.1310.006.2	8	flat washer 10.5x21
32	2.1310.004.2	2	flat washer 8.4x17
33	2.0112.309.2	4	screw m 10 p.1.5 x 25
34	2.0112.206.2	2	screw m 8 p.1.25 x 18
35	2.1011.106.2	4	nut m 10 p.1.5
36	2.1312.001.2	6	washer 4
37	2.1855.110.0	6	rivet 4.2
38	0.013.4553.0	1	insulator
39	0.013.5488.0	1	gasket

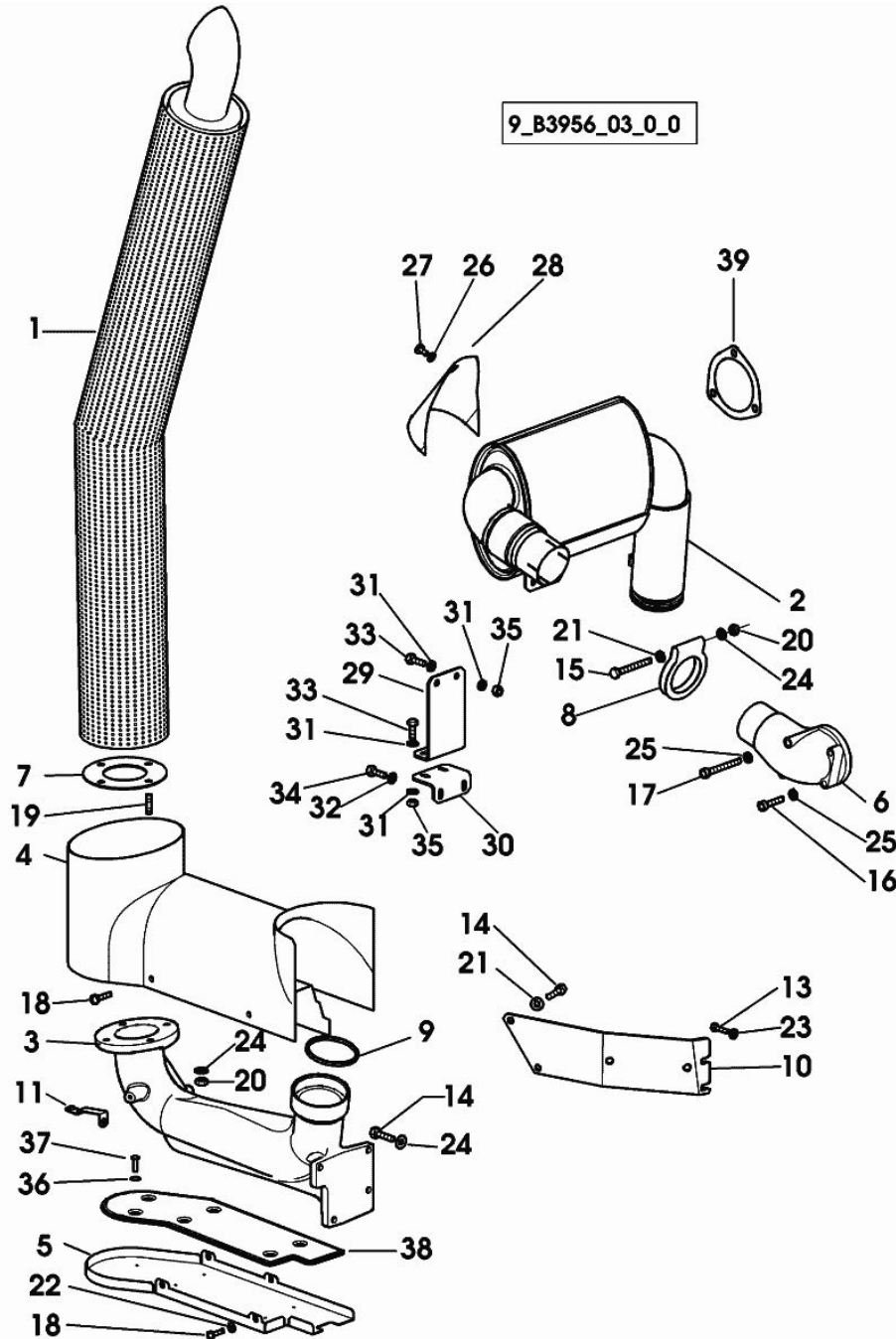

Section: ENGINE

**FUEL FILTER**

Fig.	P/n	QTY	Name
1	02111290	1	filter
2	01118647	1	oil seal 8x11,5 d7603
3	01319869	1	insert
4	01263156	1	gasket
5	01111193	1	screw m 8 p.1.25 x 80
6	01262518	1	screw
7	01318112	1	screw
8	01319821	1	bush
9	01118641	2	ring a 6x10 d7603

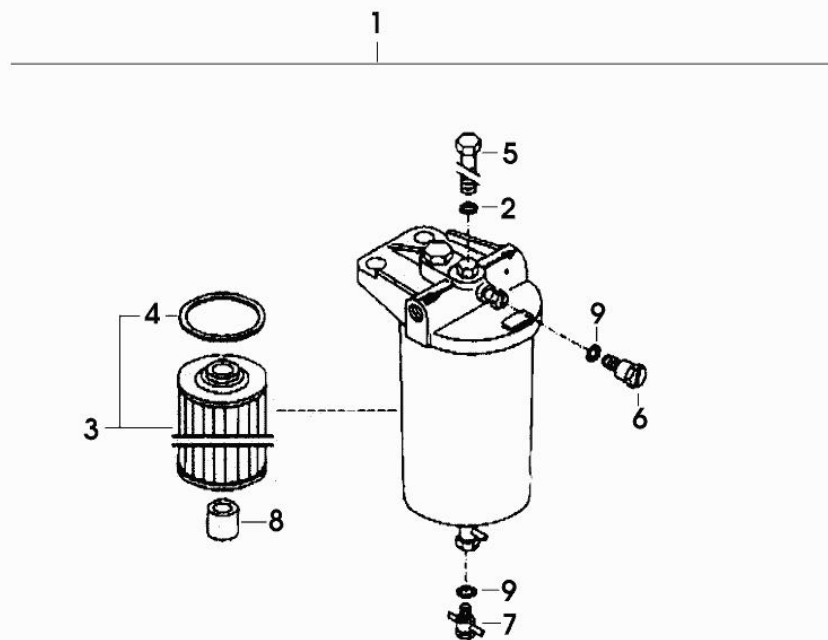

02111290

Section: ENGINE

**COMPRESSOR-PARTS**

Fig.	P/n	QTY	Name
1	04428408.4	1	air compressor 229 cm <sup>3</sup>
3	04436267	1	bushing
4	01151194	2	cover
5	04436268	1	cover
6	04436276	1	nut
7	04436269	1	piston
8	04436270	1	gasket
9	04436271	1	valve
10	04436272	1	thin plate
11	04436273	1	thin plate
13	04436275	1	cover
14	04436277	1	sub-assy parts
15	0.000.0000.1		cannot be supplied

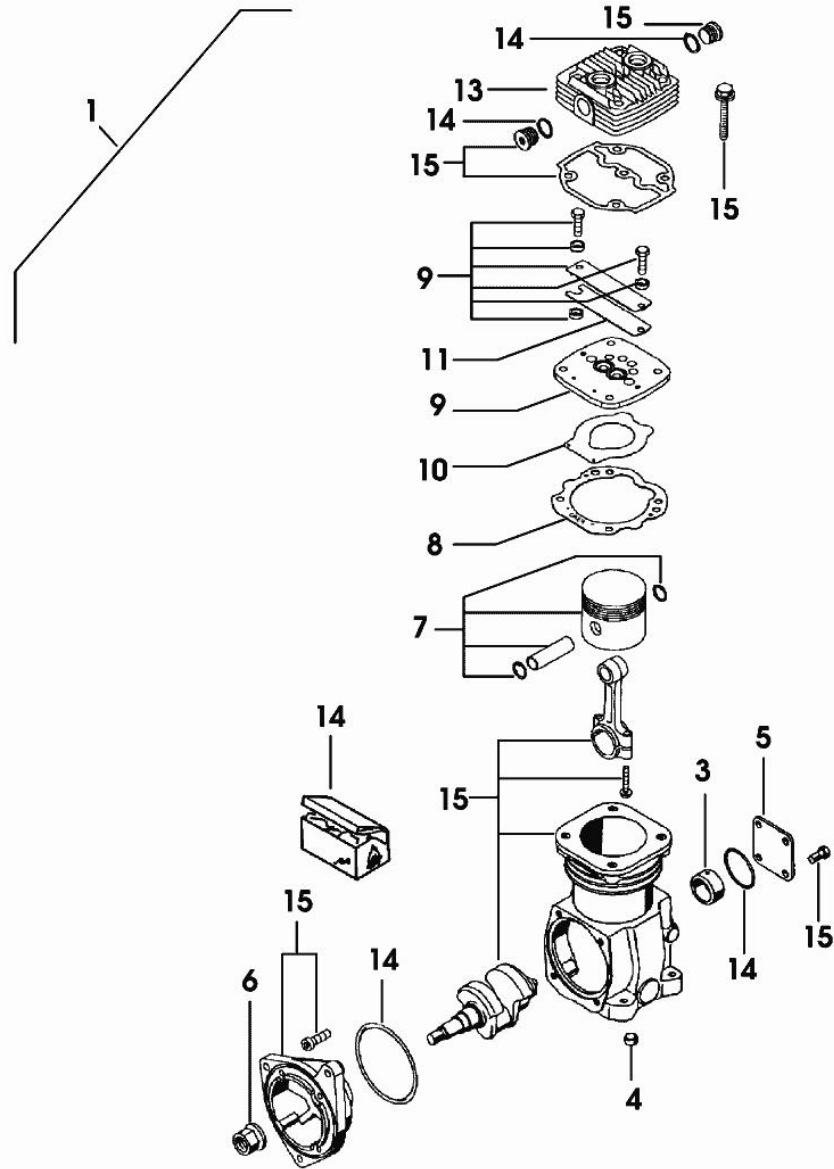

0442\_6744\_4

**Buy Now**



Our support email:

[ebooklibonline@outlook.com](mailto:ebooklibonline@outlook.com)