

Section: ENGINE
CRANKCASE

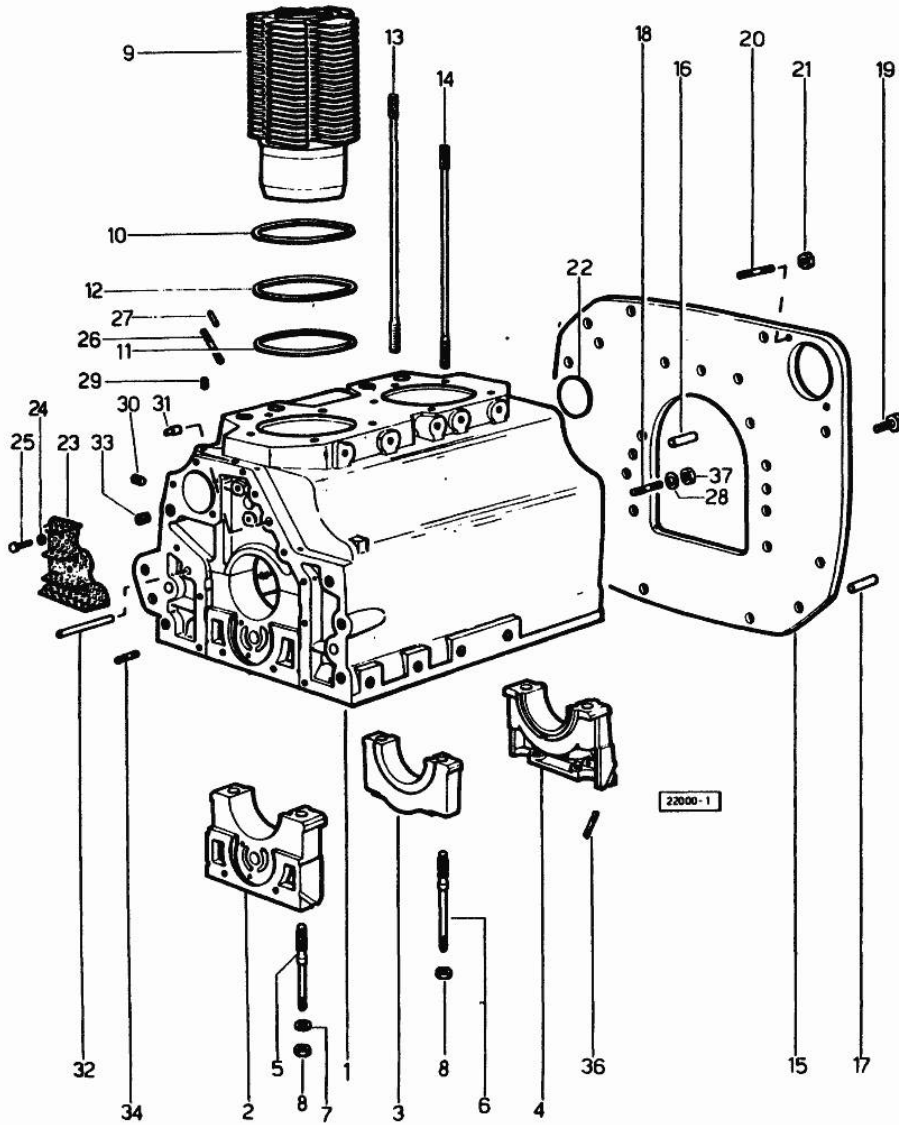

Fig.	P/n	QTY	Name
------	-----	-----	------

Notes:
 [C 362]

0	0.034.0050.6/10	1	gasket set
1	0.034.1110.4/30	1	crankcase
2	0.004.8776.0	1	support
3	0.029.1113.0	1	support
4	0.029.1116.0	1	support
5	0.021.1157.0	4	stud bolt
6	0.029.1117.0	2	stud bolt
7	2.1599.144.7	6	shoulder ring 12.5x23x4
8	2.1019.026.7	6	special nut m 12 p.1.5
9	0.036.1120.0/10	2	engine cylinder
10	2.1589.036.0	2	shim
11	2.1569.055.0	2	shim
12	2.1589.037.0	2	shim
13	0.039.1122.0	8	stud bolt m 12 p.1.5x310
14	0.037.1122.0	2	stud bolt
15	0.029.1130.0/20	1	flange
16	2.1653.708.0	2	pin 8x18
17	2.1652.911.0	2	cylindrical plug 12x25
18	2.0432.153.2	2	stud bolt
19	2.0112.511.2	11	screw m 14 p.2 x 30
20	2.0432.257.2	2	stud bolt m 12 p.1.75 - 1.25 x 30
21	2.1011.207.2	2	nut m 12 p.1.5
22	2.3170.022.1	1	expansion plug 60
23	0.029.1155.2/20	1	plate
24	2.1470.002.2	2	lock washer 6
25	2.0112.002.2	2	screw m 6 p.1 x 10
26	2.0432.159.2	2	stud bolt m 10 p.1.5 / p.1.25 x 35
27	2.1653.708.0	1	pin 8x18
28	2.1474.010.2	2	washer 10
29	2.3130.001.1	2	plug 1/8" gas
30	2.3139.001.0	2	plug m 12 p.1.75
31	2.1699.021.0	1	pin 7.8x8x20
32	2.1699.116.0	1	pin
33	2.3130.002.1	2	plug 1/4" gas
34	2.0432.018.1	5	stud bolt m 8 p.1.25 / p.1 x 65
36	0.029.1154.0	4	gasket
37	2.1011.421.2	2	nut m 10 p.1.25

Section: ENGINE
TIMING CASE

Fig.	P/n	QTY	Name
------	-----	-----	------

Notes:
[C 362]

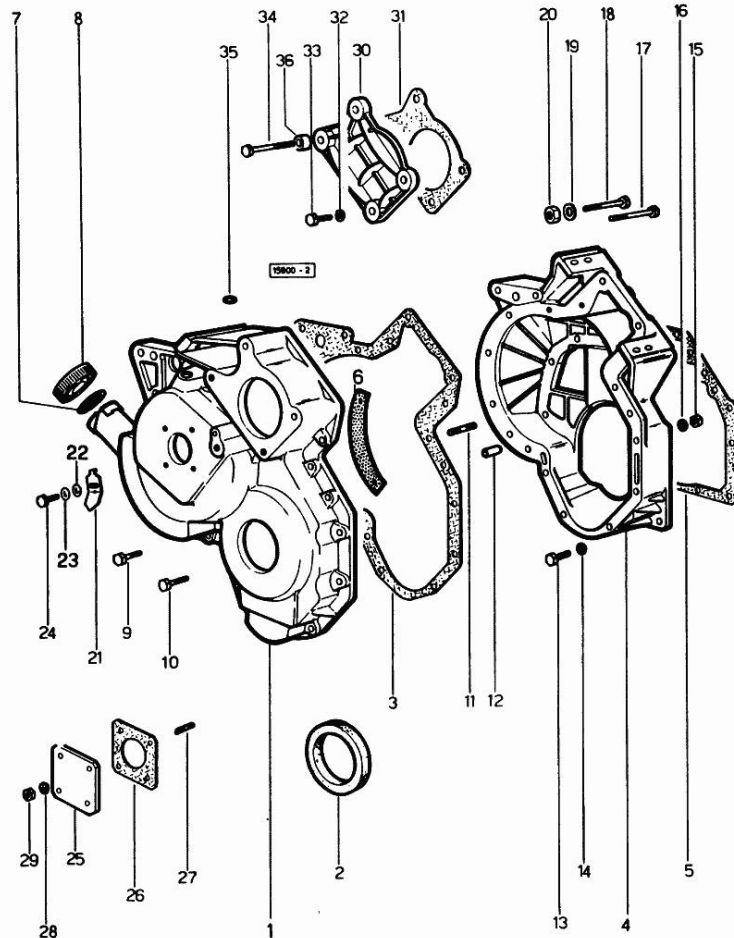

1	0.320.1554.0	1	governor housing
2	2.1519.010.0	1	special oil seal 58x80x10
3	0.027.1156.0	1	gasket
4	0.027.1154.0/30	1	flange
5	0.029.1153.0/10	1	gasket
6	0.027.1152.0/20	1	small plate
7	2.1530.074.0	1	oil seal 28.17x3.53
8	2.3199.535.0	1	plug
9	2.0122.222.1	1	screw
10	2.0122.213.2	4	screw m 8 p.1x35
11	2.0439.060.2	3	stud bolt m 8 p.1.25-1x22
12	2.1653.711.0	1	pin
13	2.0112.207.2	8	screw m 8 p 1.25 x 20
14	2.1474.009.2	8	spring washer 8
15	2.1011.405.2	15	nut m 8 p.1
16	2.1474.009.2	15	spring washer 8
17	2.0122.225.2	1	screw m 8 p.1x80
18	2.0122.225.2	1	screw m 8 p.1x80
19	2.1474.009.2	2	spring washer 8
20	2.1011.405.2	3	nut m 8 p.1
21	0.027.1150.0/10	1	index
22	2.1310.003.2	1	flat washer 7.4x14
23	2.1470.003.1	1	lock washer
24	2.0112.204.2	1	screw m 8 p.1.25x14
25	0.027.1153.0	1	flange
26	0.026.1150.0	1	gasket
27	2.0439.055.2	4	stud bolt
28	2.1470.002.2	4	lock washer 6
29	2.1011.103.2	4	nut m 6 p.1
30	0.029.1163.0	1	small cover
31	0.054.1155.0	1	gasket
32	2.1474.009.2	2	spring washer 8
33	2.0112.211.2	2	screw m 8 p.1.25 x 30
34	2.0122.233.2	2	screw
35	2.1530.028.0	1	oil seal 11.91 x 2.62

Section: ENGINE

CRANKSHAFT

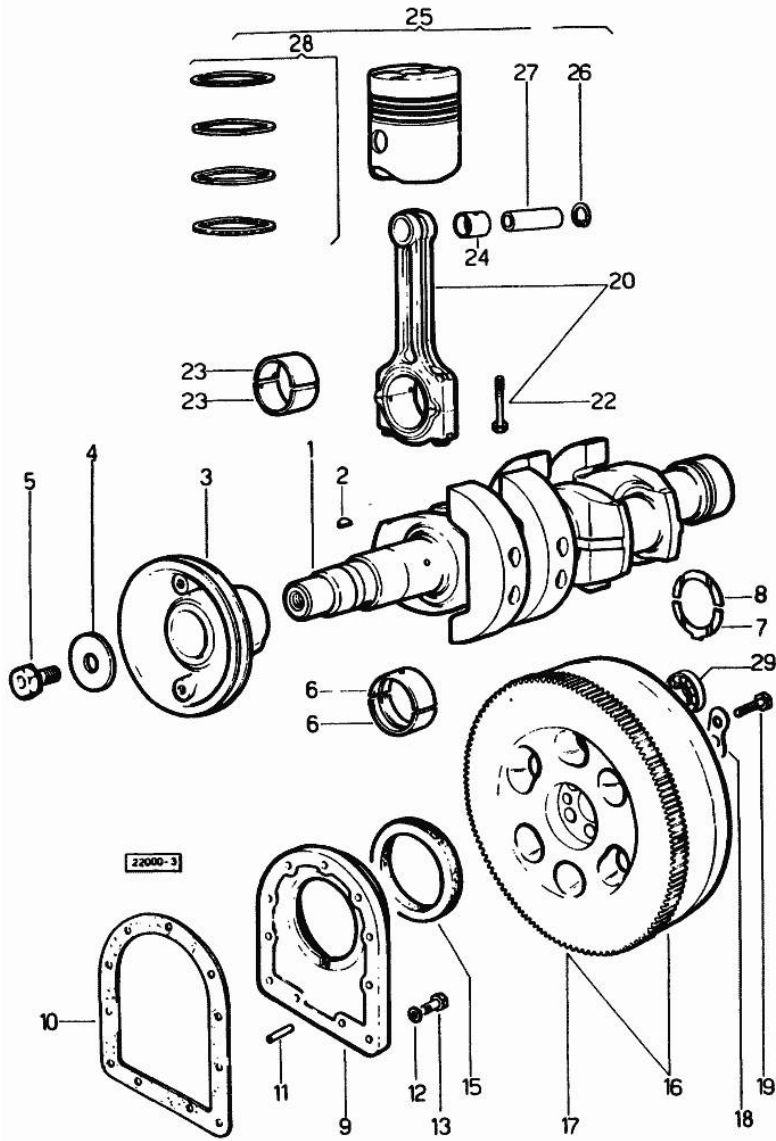

Notes:
[C 362]

Fig.	P/n	QTY	Name
1	0.027.1210.4/30	1	crankshaft
2	2.1799.002.0	1	stick 10x13
3	0.027.1244.0/30	1	pulley
4	0.001.6020.0	1	shoulder
5	2.0129.032.2	1	screw m 24 p.2x45
6	0.029.0066.0		main half bushing - mm 1.00
6	0.029.1215.0/10	6	main half bushing
6	0.029.1215.7		main half bushing - mm 0.25
6	0.029.1215.8		main half bushing - mm 0.50
6	0.029.1215.9		main half bushing - mm 0.75
7	0.001.4547.0		shoulder ring + mm 0.05
7	0.001.4548.0		shoulder ring + mm 0.10
7	0.001.4549.0		shoulder ring + mm 0.15
7	0.042.1219.0	2	shoulder ring STANDARD
8	0.001.4544.0		shoulder ring + mm 0.05
8	0.001.4545.0		shoulder ring + mm 0.10
8	0.001.4546.0		shoulder ring + mm 0.15
8	0.042.1218.0	2	shoulder ring STANDARD
9	0.029.1240.0	1	flange
10	0.029.1250.0	1	gasket
11	2.1652.915.0	2	cylindrical plug 12x35
12	2.1474.010.2	6	washer 10
13	2.0112.309.2	7	screw m 10 p.1.5 x 25
15	2.1519.009.0	1	special oil seal
16	0.034.1263.3	1	flywheel
17	0.038.1242.0	1	crown wheel Z = 120, mm 15
18	2.1379.006.0	3	lock-tab 15x15x36,5
19	2.0122.517.2	6	screw m 14 p.1.5x45
20	0.052.1220.3	2	engine connecting rod
22	0.039.1250.0	4	screw m 14 p.1.5x63
23	0.039.0068.0		con.rod half bushing - mm 1.016
23	0.039.1225.0	4	con.rod half bushing
23	0.039.1225.7		con.rod half bushing -mm 0.254
23	0.039.1225.8		con.rod half bushing -mm 0.508
23	0.039.1225.9		con.rod half bushing -mm 0.762
24	0.002.4168.0	2	bearing
25	0.036.0060.6	2	complete piston
25	0.036.0061.6		complete piston + mm 0.5
25	0.036.0062.6		complete piston + mm 1.00
26	2.1411.014.1	4	circlip 35
27	0.002.4167.0	2	piston pin

Section: ENGINE
CRANKSHAFT

Fig.	P/n	QTY	Name
28	0.034.0052.6	2	piston ring set
28	0.034.0053.6	1	piston ring set + mm 0.5
28	0.034.0054.6	1	piston ring set + mm 1.0
29	2.2061.005.0	1	ball bearing iso 17 bc 03

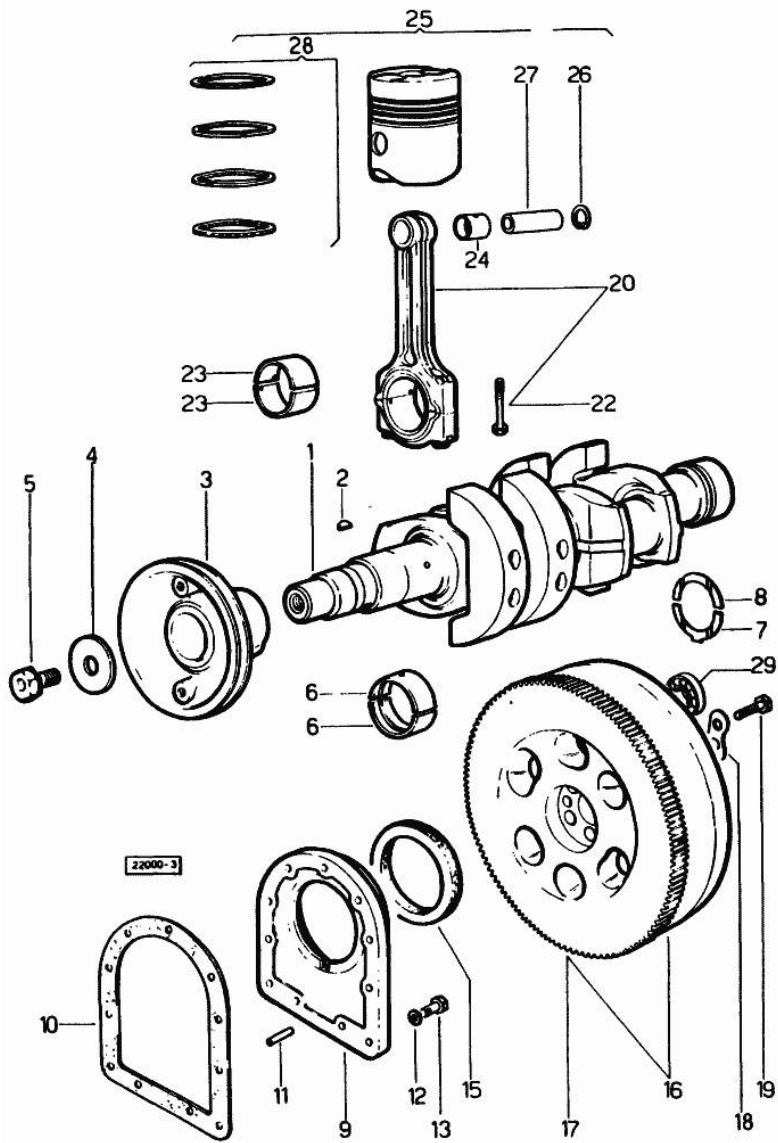

CAMSHAFT

Fig.	P/n	QTY	Name
------	-----	-----	------

Notes:

[C 362]

1	0.027.1351.0/20	1	camshaft
2	0.027.1350.0/20	1	pin
3	0.027.1314.0	1	flange
4	2.1470.004.2	2	lock washer 8
5	2.0312.206.2	2	screw m 8 p 1.25 x 20
6	2.1720.010.0	1	key 5x9
7	0.029.1320.0/10	1	gear wheel
8	0.035.1321.0	1	gear
10	2.0139.006.1	4	screw
11	0.002.3909.0	4	tappets
12	0.037.1331.0	4	rod
13	2.1539.018.0	4	special oil seal
14	0.039.1332.0/10	4	sleeve
15	2.1539.022.0	4	special oil seal 12.37x2.62
16	2.4019.149.1	4	spring 14x29x2
17	2.1569.037.0	4	gasket
18	2.1650.513.0	1	pin 6 x 30

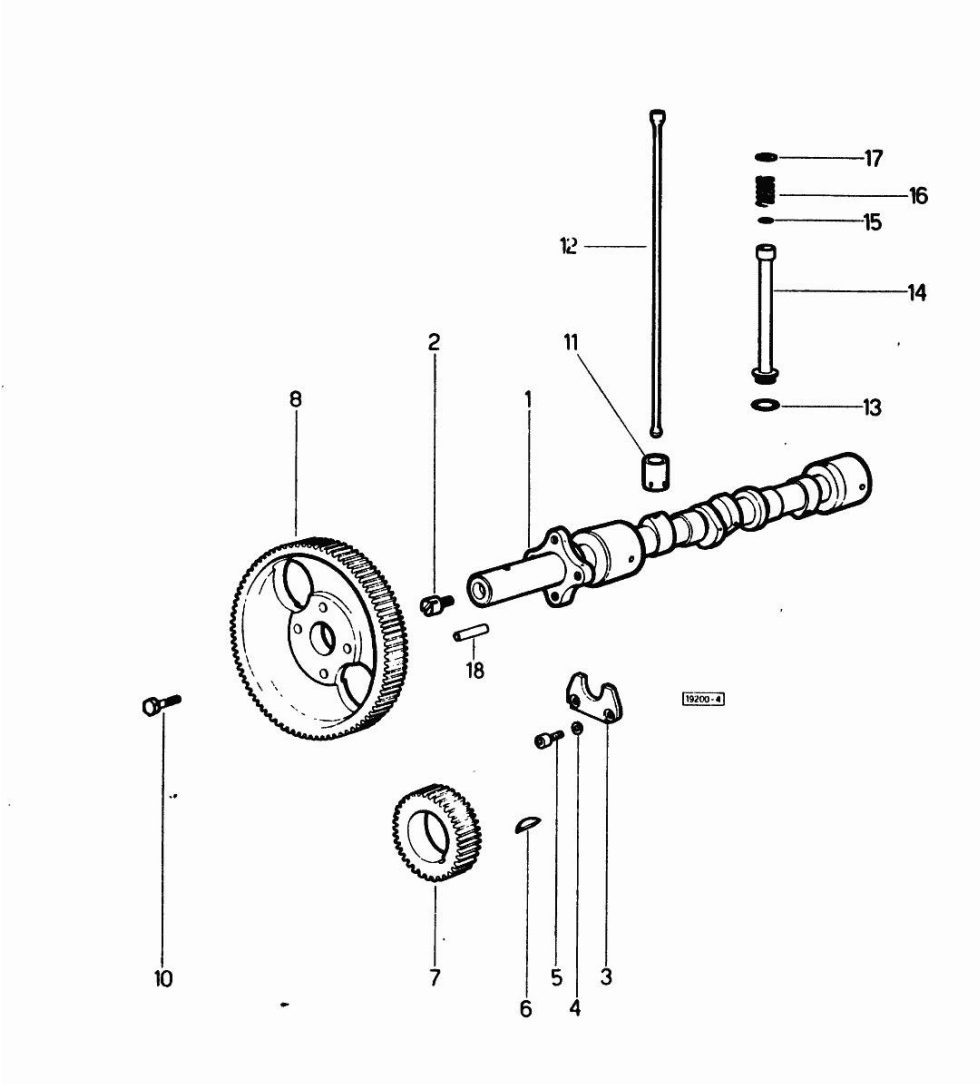

Section: ENGINE
 CYLINDER HEAD

Fig.	P/n	QTY	Name
Notes:			
[C 362]			
0	0.034.0057.6	1	gasket set - FOR 1 CYLINDER VALVE GRINDING AND PISTON RINGS REPLACEMENT
1	0.037.1450.3/30	2	engine head
2	0.037.1416.0	2	valve guide
3	0.037.1417.0/10	2	valve guide
4	0.037.1451.0/10	2	valve seat
5	0.037.1452.0/10	2	valve seat
6	2.0432.007.2	2	stud bolt m 8 p.1.25 / p.1 x 30
6	2.0432.011.1	4	stud bolt m 8 p.1.25 / p.1 x 40
7	0.029.1418.0	4	sleeve
8	2.1569.056.0/10	2	gasket
9	2.0439.087.1	4	stud bolt
10	2.1599.144.7	8	shoulder ring 12.5x23x4
11	2.1019.025.1	6	special nut
12	2.1019.037.1	2	nut m 12 p.1.5x35
13	0.029.1450.0	2	gasket
14	0.039.1440.0	2	cap
15	2.1560.004.0	2	copper gasket 8.2 x 14
16	2.1099.056.1	2	special nut m8 p.1
17	0.034.1430.0	2	support
18	0.029.1452.0	2	tube
19	0.034.1450.0	2	tappet gasket
20	002.5937.3/30	2	rocker arm
21	2.1559.021.0/40	2	bushing 15x19x22
22	0.002.5936.3/40	2	rocker arm
23	2.1559.021.0/40	2	bushing 15x19x22
24	0.029.1431.0	2	pin
25	2.0512.102.2	2	screw m 6 p.1 x 8
26	2.1599.019.0	4	shoulder ring 19.5x31x2
27	2.1410.055.1	4	circlip 19
28	0.021.1434.0	4	screw
29	2.1011.405.2	4	nut m 8 p.1
30	0.039.1451.0	2	stud bolt
31	0.039.1421.0	2	exhaust valve Ø mm 9
32	0.053.1420.0	2	inlet valve
33	2.4019.193.0	4	spring 36.15x55.2x3.2
34	2.4019.194.0	4	spring 22.70x50.7x2.1
35	0.002.9215.0/10	4	cup
36	0.002.9193.0/10	8	conical valve cotter
37	0.021.1453.0/20	4	small cover

Section: ENGINE
CYLINDER HEAD

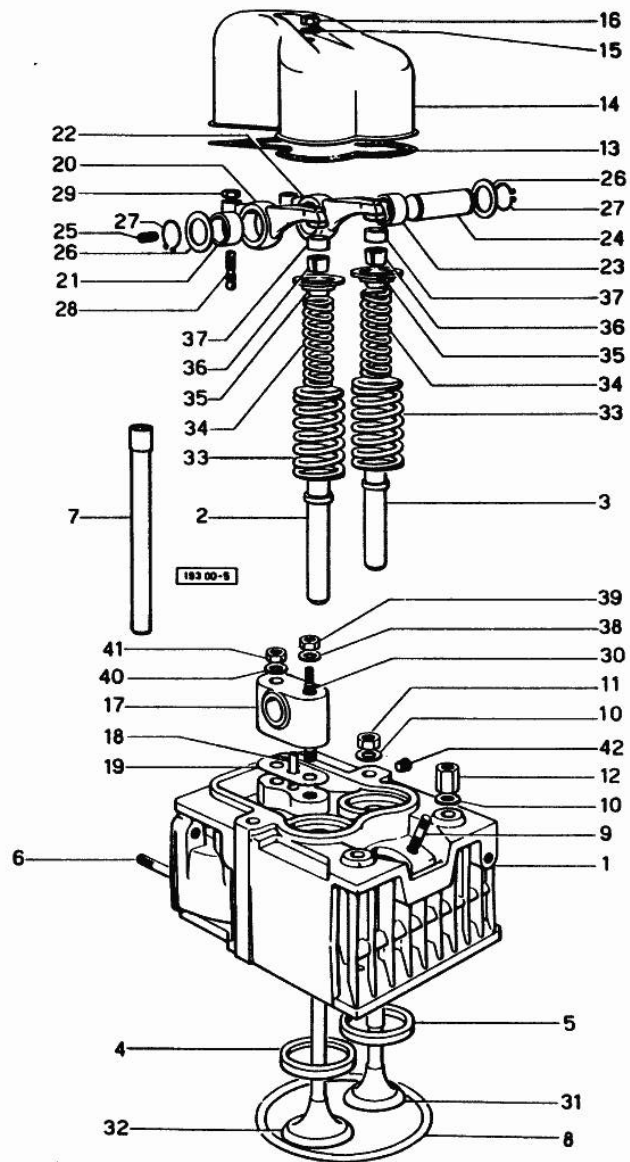
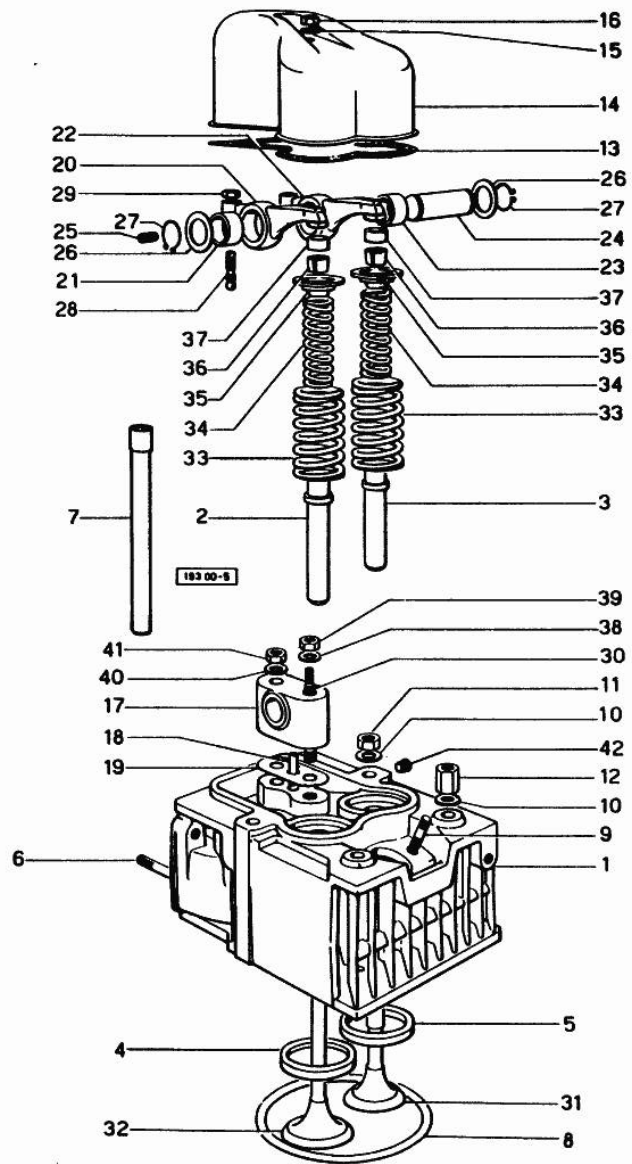

Fig.	P/n	QTY	Name
38	2.1310.006.2	2	flat washer 10.5x21
39	2.1011.421.2	2	nut m 10 p.1.25
40	2.1599.160.0	2	washer 10.5x19x4
41	2.1099.035.7	2	special nut
42	2.3130.001.1	2	plug 1/8" gas

Buy Now



Our support email:

ebooklibonline@outlook.com