

Section: ENGINE
CRANKCASE

Fig.	P/n	QTY	Name
------	-----	-----	------

Notes:

3683 <= [C 653]

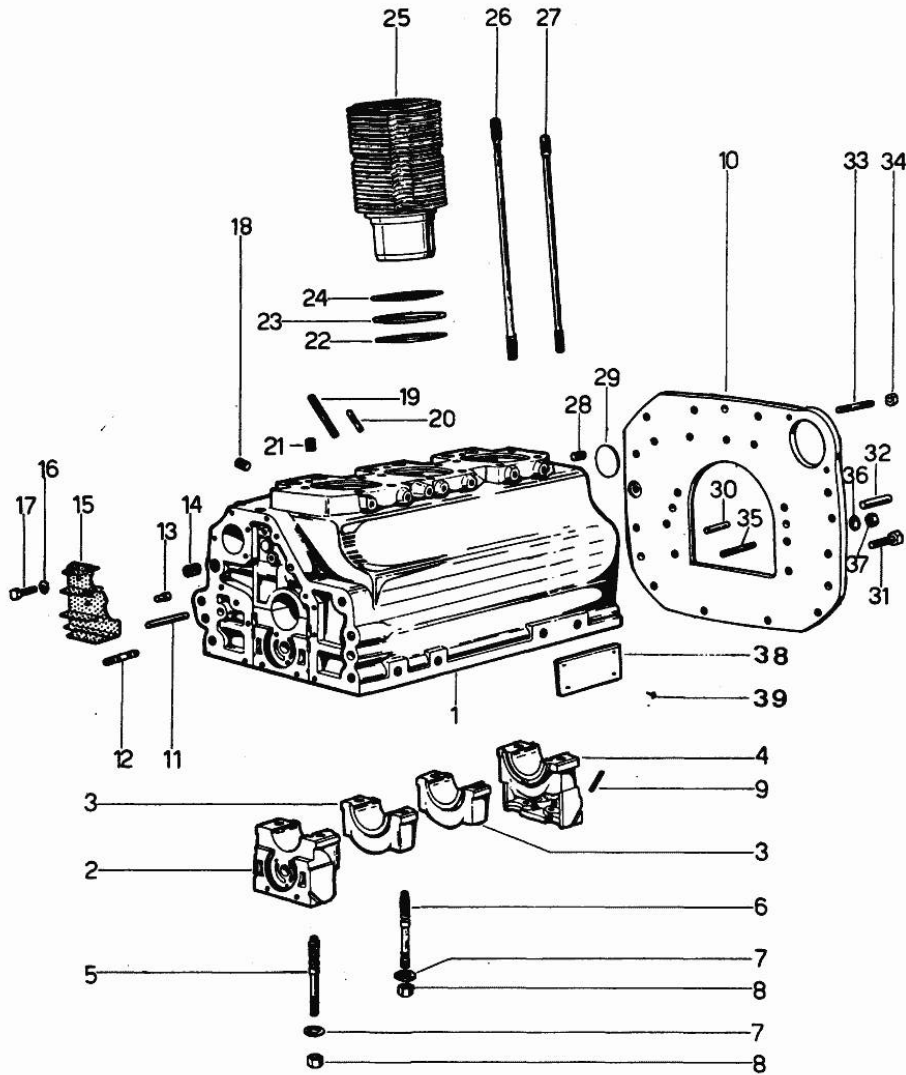

0	0.316.0050.6	1	gasket set
1	0.035.1110.4/10	1	crankcase
2	0.029.1112.0	1	support
3	0.029.1113.0	2	support
4	0.029.1116.0	1	support
5	0.021.1157.0	4	stud bolt
6	0.029.1117.0	1	stud bolt
7	2.1599.144.0	8	shoulder
8	2.1019.026.1	8	special nut m 12 p.1.5
9	0.029.1134.0	4	-
10	0.029.1130.0/10	1	flange
11	2.1652.724.0	1	pin
12	2.0432.018.1	5	stud bolt m 8 p.1.25 / p.1 x 65
13	2.1699.021.0	1	pin 7.8x8x20
14	2.3130.002.1	1	plug 1/4" gas
15	0.029.1155.2/10	1	plate
16	2.1470.002.2	2	lock washer 6
17	2.0112.003.2	2	screw m 6 p.1 x 12
18	2.3139.001.0	3	plug m 12 p.1.75
19	2.0432.267.1	2	stud bolt m 12 p.1.75-1.25x60
20	2.1652.708.0	1	cylindrical plug 8x18
21	2.3130.001.1	3	plug 1/8" gas
22	2.1569.055.0	3	shim
23	2.1589.037.0	3	shim
24	2.1589.036.0	3	shim
25	0.039.1120.0/10	3	engine cylinder
26	0.029.1123.0	12	stud bolt m 12 p.1.5x265
26	0.039.1122.0	12	stud bolt m 12 p.1.5x310
27	0.034.1122.0	3	stud bolt
27	0.037.1122.0	3	stud bolt
28	2.3130.002.1	1	plug 1/4" gas
29	2.3170.022.1	1	expansion plug 60
30	2.1652.708.0	2	cylindrical plug 8x18
31	2.0112.511.1	11	screw m 14 p.2 x 30
32	2.1652.911.0	2	cylindrical plug 12x25
33	2.0439.033.1	2	stud bolt m 10x28
34	2.1011.106.2	2	nut m 10 p.1.5

Section: ENGINE
CRANKCASE

Fig.	P/n	QTY	Name
35	2.0432.155.1	2	stud bolt m 10 p.1.5 / p. 1.25 x 25
36	2.1480.015.2	2	washer 10
37	2.1011.406.1	2	nut m 10 p.1
38	2.9919.505.0	1	plate
39	2.1830.010.0	4	rivet

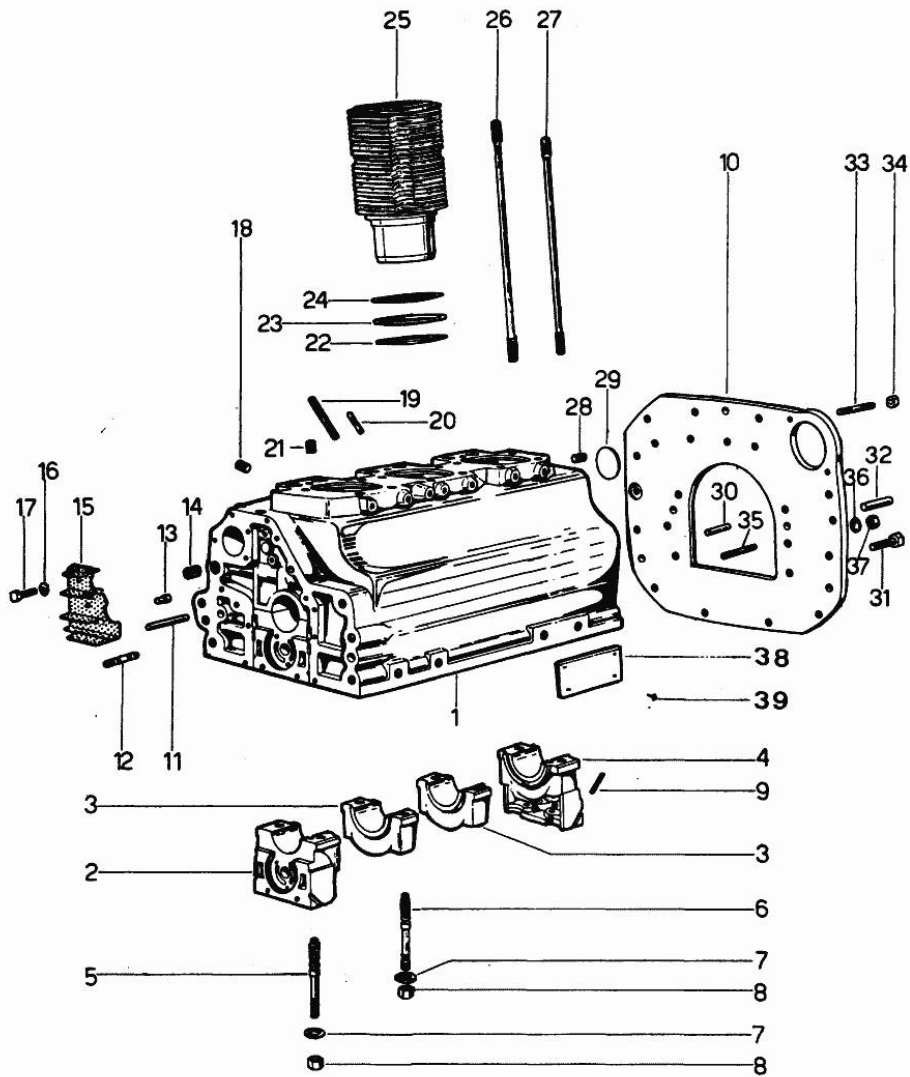

43300-1

Section: ENGINE

TIMING CASE

Fig.	P/n	QTY	Name
------	-----	-----	------

Notes:

3683 <= [C 653]

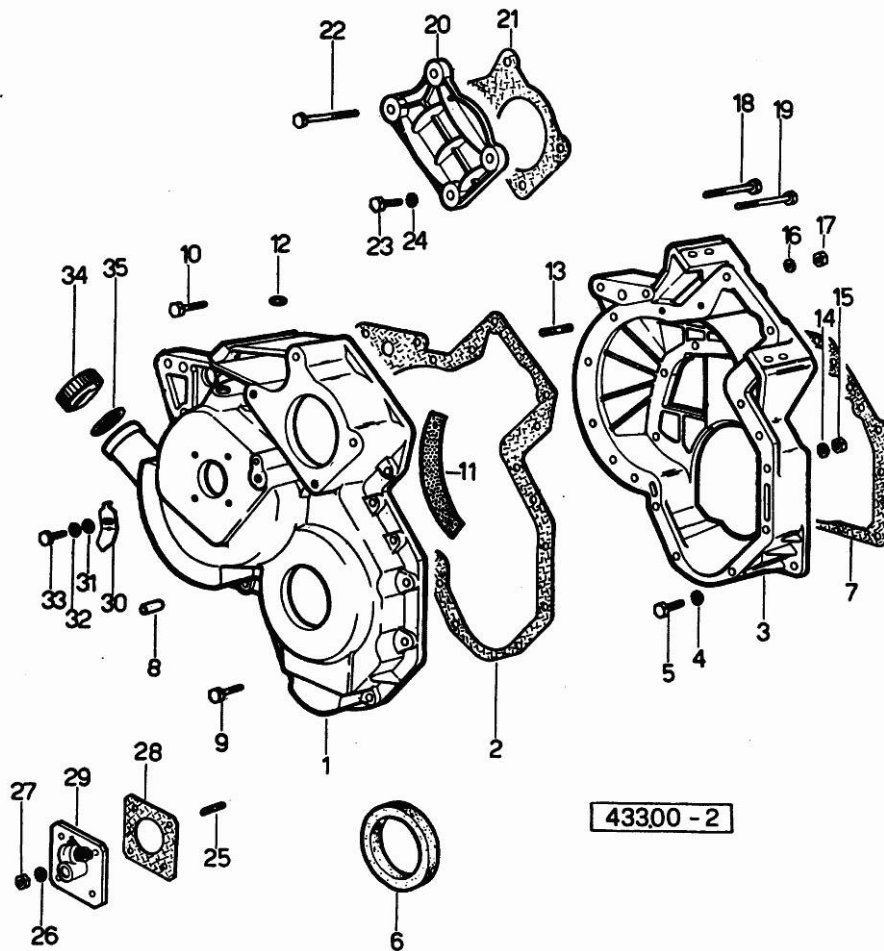

1	0.027.1155.0/30	1	governor housing
2	0.027.1156.0	1	gasket
3	0.027.1154.0/30	1	flange
4	2.1480.014.2	8	washer 8
5	2.0112.207.1	8	screw m 8 p 1.25 x 20
6	2.1519.010.0	1	special oil seal 58x80x10
7	0.029.1153.0/10	1	gasket
8	2.1652.711.0	1	cylindrical plug 8x25
9	2.0122.213.1	4	screw
10	2.0122.222.1	1	screw
11	0.027.1152.0/20	1	small plate
12	2.1530.028.0	1	oil seal 11.91 x 2.62
13	2.0439.060.2	3	stud bolt m 8 p.1.25-1x22
14	2.1480.014.2	15	washer 8
15	2.1011.405.2	15	nut m 8 p.1
16	2.1480.014.2	2	washer 8
17	2.1011.405.2	3	nut m 8 p.1
18	2.0122.224.1	1	screw
19	2.0152.224.1	1	screw
20	0.029.1163.0	1	small cover
21	0.700.1253.0	1	gasket
22	2.0122.229.1	2	screw m 8 x 100
23	2.0122.211.2	2	screw m 8 p.1x30
24	2.1470.004.1	2	washer
25	2.0439.055.1	4	stud bolt m 6 p.1 x 18
26	2.1480.012.1	4	washer 6, d128
27	2.1011.103.1	4	nut
28	0.026.1150.0	1	gasket
29	2.7049.210.0/20	1	transmission
30	0.027.1150.0/10	1	index
31	2.1310.003.2	1	flat washer 7.4x14
32	2.1470.003.1	1	lock washer
33	2.0112.103.1	1	screw m 7 p.1.x12
34	0.022.1135.3	1	plug
35	2.1569.048.0	1	gasket

Section: ENGINE
CRANKSHAFT

Fig.	P/n	QTY	Name
------	-----	-----	------

Notes:

3683 <- [C 653]

1	0.029.1210.4/20	1	crankshaft 56322 <=
1	0.029.1210.4/30	1	crankshaft => 56323
2	2.1799.002.0	1	stick 10x13
3	0.038.1244.0	1	pulley
4	0.001.6020.0	1	shoulder
5	2.0129.032.2	1	screw m 24 p.2x45
6	0.029.0066.0	8	main half bushing - mm 1.00
6	0.029.1215.0	8	main half bushing
6	0.029.1215.7	8	main half bushing - mm 0.25
6	0.029.1215.8	8	main half bushing - mm 0.50
6	0.029.1215.9	8	main half bushing - mm 0.75
7	0.001.4196.0	2	shoulder ring
7	0.001.4547.0	2	shoulder ring + mm 0.05
7	0.001.4548.0	2	shoulder ring + mm 0.10
7	0.001.4549.0	2	shoulder ring + mm 0.15
8	0.001.4197.0	2	shoulder ring
8	0.001.4544.0	2	shoulder ring + mm 0.05
8	0.001.4545.0	2	shoulder ring + mm 0.10
8	0.001.4546.0	2	shoulder ring + mm 0.15
9	2.1652.915.0	2	cylindrical plug 12x35
10	0.029.1250.0	1	gasket
11	0.029.1240.0	1	flange
12	2.1480.015.1	7	washer 10
13	2.0112.309.1	7	screw
14	2.1519.009.0	1	special oil seal
15	0.316.1247.3	1	flywheel
16	0.316.1242.0	1	crown wheel
17	2.1399.506.0	3	lock-tab
18	2.0122.515.1	6	screw
19	0.029.1220.3	3	engine connecting rod 56322 <=
19	0.039.1220.3/30	3	engine connecting rod => 56323
20	0.002.3910.0	6	screw 56322 <=
20	0.039.1250.0	6	screw m 14 p.1.5x63 => 68323
21	0.021.0068.0	6	con.rod half bushing 56322 <=

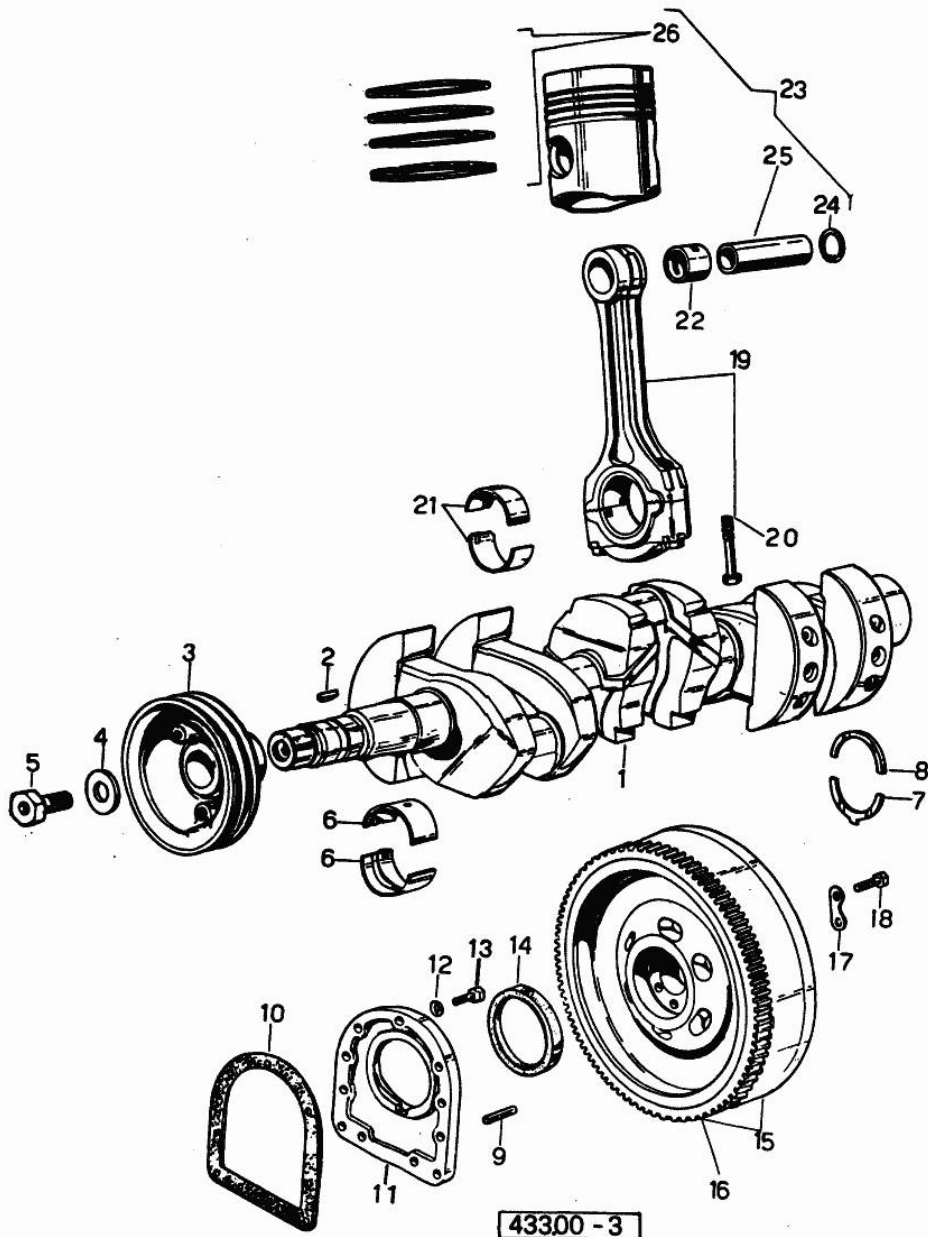

Section: ENGINE
CRANKSHAFT

Fig.	P/n	QTY	Name
21	0.021.1225.0	6	con.rod half bushing STANDARD 56322 <=
21	0.021.1225.7	6	con.rod half bushing - mm 0.25 56322 <=
21	0.021.1225.8	6	con.rod half bushing - mm 0.50 56322 <=
21	0.021.1225.9	6	con.rod half bushing - mm 0.75 56322 <=
21	0.039.0068.0	6	con.rod half bushing - mm 1.016 => 56323
21	0.039.1225.0	6	con.rod half bushing => 56323
21	0.039.1225.7	6	con.rod half bushing -mm 0.254 => 56323
21	0.039.1225.8	6	con.rod half bushing -mm 0.508 => 56323
21	0.039.1225.9	6	con.rod half bushing -mm 0.762 => 56323
22	0.002.4168.0	3	bearing
24	2.1411.014.1	8	circlip 35
25	0.038.1236.0	3	piston pin

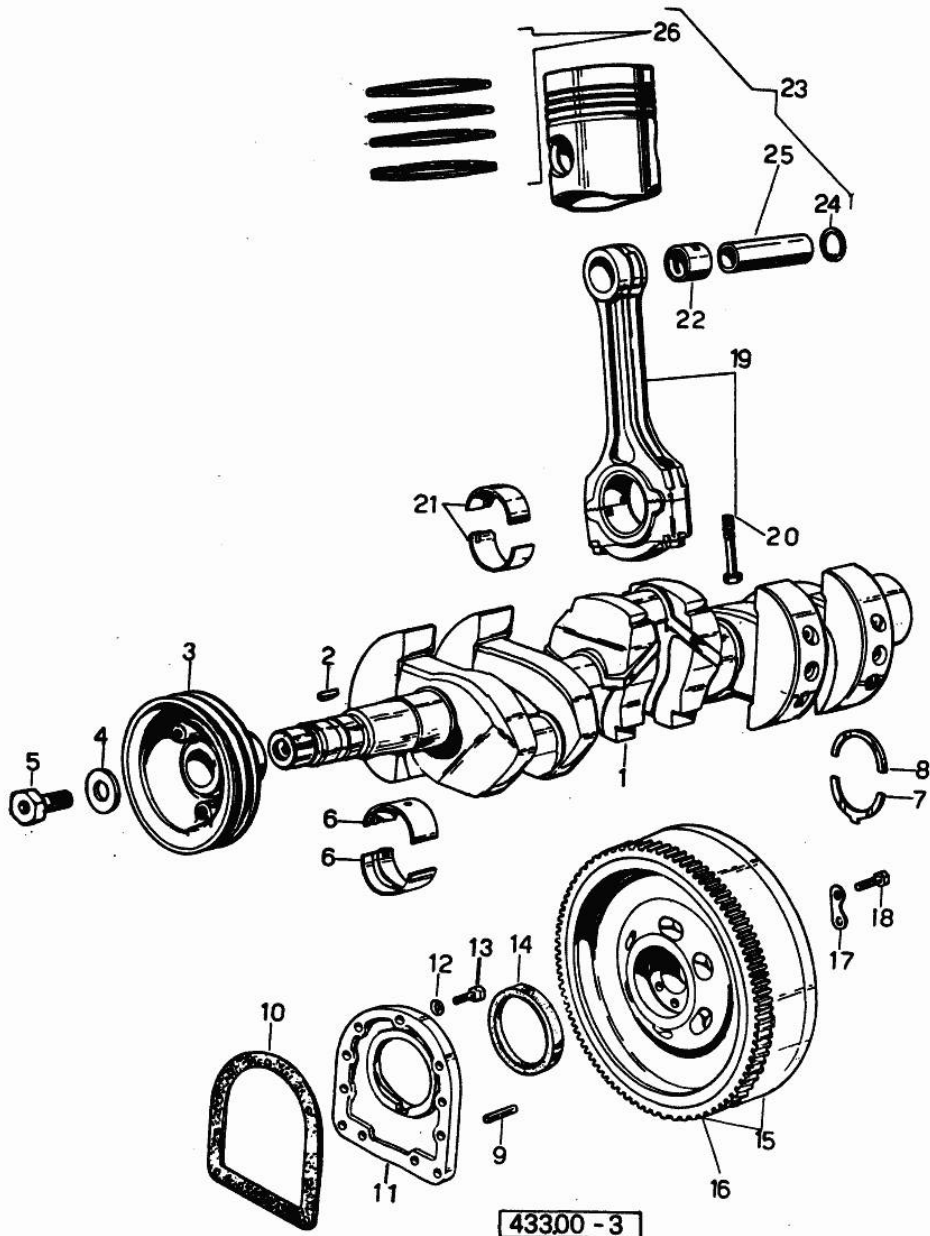

Section: ENGINE

CAMSHAFT

Fig.	P/n	QTY	Name
------	-----	-----	------

Notes:

3683 <= [C 653]

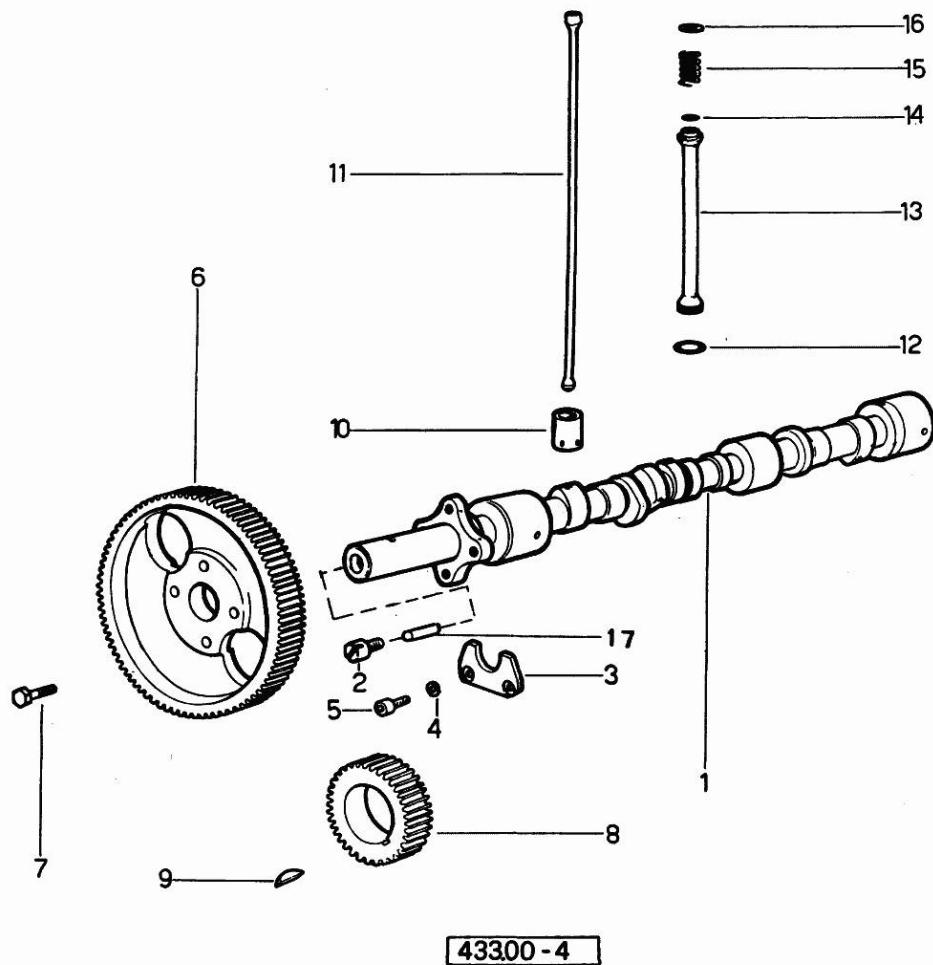

1	0.035.1310.0	1	camshaft
2	0.027.1350.0/20	1	pin
3	0.027.1314.0	1	flange
4	2.1470.004.2	2	lock washer 8
5	2.0312.206.2	2	screw m 8 p 1.25 x 20
6	0.035.1321.0	1	gear
7	2.0139.006.1	4	screw
8	0.029.1320.0	1	gear Z = 45
9	2.1720.010.0	1	key 5x9
10	0.002.3909.0	6	tappets
11	0.037.1331.0	6	rod
12	2.1539.018.0	6	special oil seal
13	0.039.1332.0/10	6	sleeve
14	2.1539.022.0	6	special oil seal 12.37x2.62
15	2.4019.149.1	6	spring 14x29x2
16	2.1569.037.0	6	gasket
17	2.1650.513.0	1	pin 6 x 30

Section: ENGINE
CYLINDER HEAD

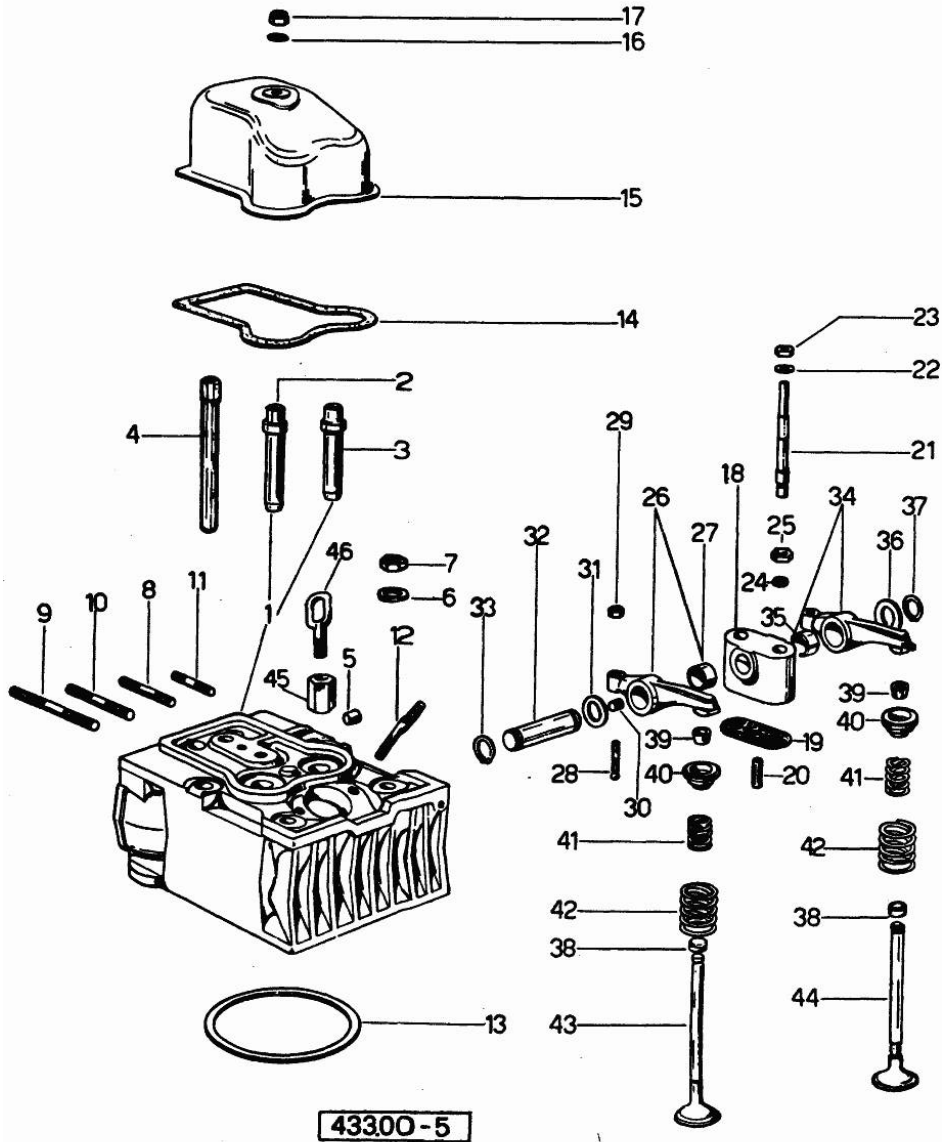

Fig.	P/n	QTY	Name
------	-----	-----	------

Notes:
- X C 603 [C 653]

0	0.038.0058.6	1	gasket set
1	0.038.1410.6/20	3	engine head
2	0.037.1416.0	3	valve guide
3	0.037.1417.0/10	3	valve guide
4	0.029.1418.0	6	sleeve
5	2.3199.026.1	3	plug
6	2.1599.144.0	12	shoulder
7	2.1019.025.1	10	special nut
8	2.0432.007.1	3	stud bolt m 8 p.1.25 / p.1 x 30
9	2.0432.026.1	2	stud bolt m 8 p.1.25 - 1.00 x 110
10	2.0432.022.1	1	stud bolt m 8 p 1.25-1x85
11	2.0432.001.1	6	stud bolt m 14 p.2-1.5x35
12	2.0439.019.1	6	stud bolt
13	2.1569.061.0	3	gasket
14	0.029.1450.0	3	gasket
15	0.029.1440.2	3	cap
16	2.1560.004.0	3	copper gasket 8.2 x 14
17	2.1031.102.2	3	special nut
18	0.034.1430.0	3	support
19	0.034.1450.0	3	tappet gasket
20	0.029.1452.0	3	tube
21	0.029.1453.0/10	3	stud bolt
22	2.1310.006.0	3	flat washer
23	2.1011.421.1	3	nut
24	2.1599.160.0	3	washer 10.5x19x4
25	2.1099.035.1	3	special nut
26	0.002.5937.3/10	3	rocker arm
27	2.1559.021.0/20	3	special bushing
28	0.021.7434.0	6	-
29	2.1011.405.1	6	nut
30	2.0512.102.1	3	screw m 6 p.1 x 8
31	2.1599.019.0	3	shoulder ring 19.5x31x2
32	0.029.1431.0	3	pin
33	2.1410.055.1	2	circlip 19
34	0.002.5936.3/20	3	rocker arm
35	2.1559.021.0/20	3	special bushing
36	2.1599.010.0	3	shoulder ring 41 x 63 x 4.0
37	2.1410.055.1	3	circlip 19
38	0.021.1453.0/10	6	small cover
39	0.002.9193.0	6	conical valve cotter
40	0.002.9215.0	6	cup

Buy Now



Our support email:

ebooklibonline@outlook.com