

Section: ENGINE  
CRANKCASE

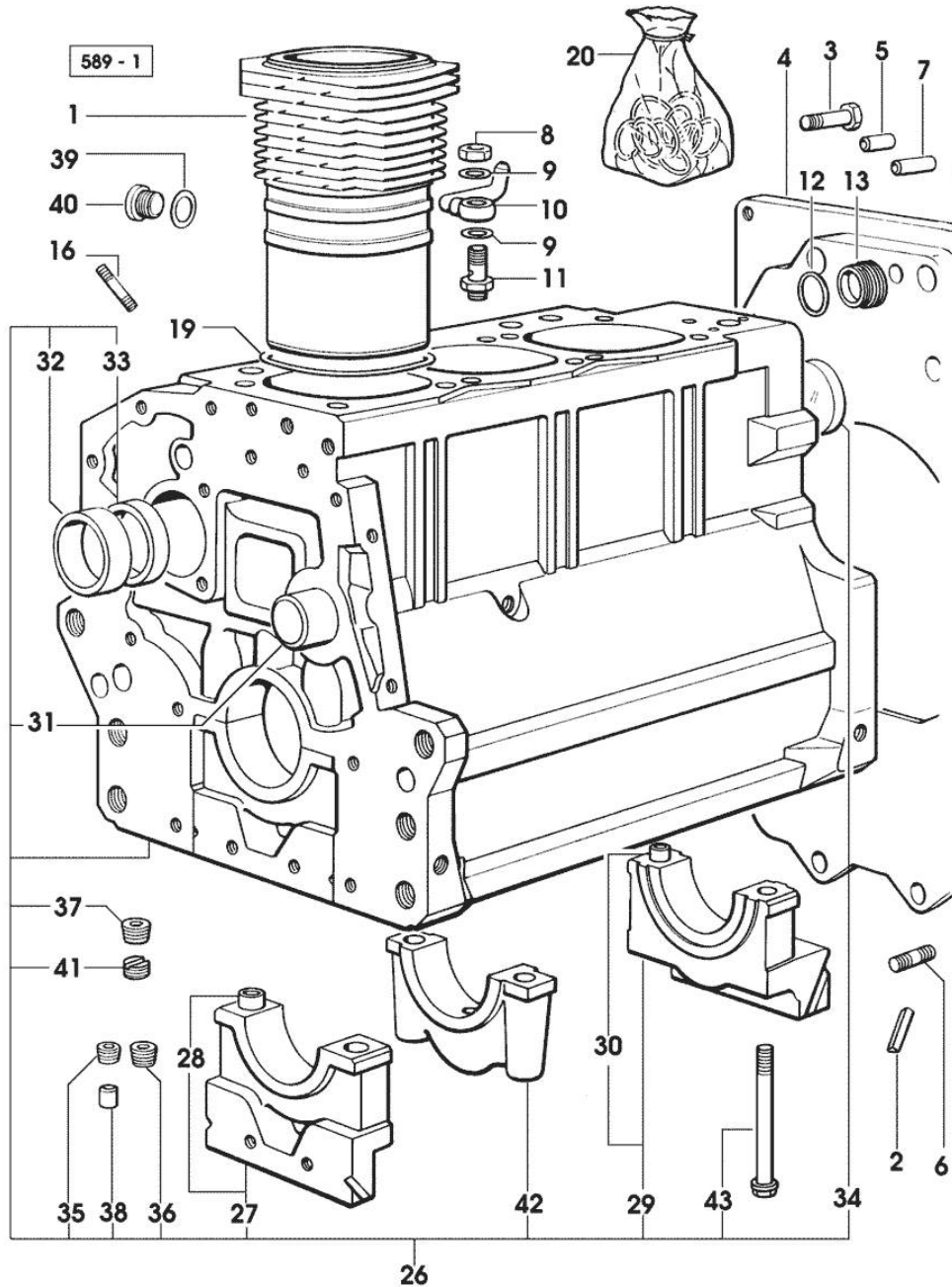

Fig.	P/n	QTY	Name
------	-----	-----	------

Notes:  
[CRONO 564-60]

1	0.007.0762.0/50	3	engine cylinder
2	0.066.1152.0/10	4	gasket
3	2.0112.511.1	8	screw m 14 p.2 x 30
4	0.007.1618.0/20	1	flange - X CRONO 554-50
4	0.007.7752.0/10	1	flange - X CRONO 564-60 - 574-70
5	2.1651.912.0	2	cylindrical plug 12x28
6	2.0432.255.7	2	stud bolt m 12 p.1.75-1.25x25
7	2.1651.917.0	1	cylindrical plug 12x40
8	2.1099.108.2	3	special nut m 10 p.1
9	2.1560.006.0	6	gasket 10.2 x 16
10	0.086.1550.2	3	sprayer nozzle
11	0.065.1160.3/20	3	valve
12	2.1539.047.0	1	special oil seal 26.7x1.78
13	2.3199.405.2	1	plug m 28 p.1.5
16	2.0432.003.7	9	stud bolt m 8 p.1.25 / p.1 x 20
19	2.1539.130.0/10	3	special oil seal 117.07x3.53
20	0.085.0050.6/10	1	gasket set - X CRONO 554-50 - 564-60 - FOR ENGINE MOUNTING
20	0.351.0050.6/10	1	gasket set - X CRONO 574-70 - FOR ENGINE MOUNTING
26	0.007.1150.6/10	1	crankcase * 2415 <= X CRONO 554-50 * 2051 <= X CRONO 564-60 * 3925 <= X CRONO 574-70 - N.1 - 085.1750.2/10 - 009.7871.0
27	0.065.1112.7	1	support
28	2.1699.165.0	1	bush 12.3x15x16
29	0.065.1116.3	1	support
30	2.1699.165.0	1	bush 12.3x15x16
31	0.066.1151.0	1	pin
32	0.065.1141.0	1	special bushing 59X55X30
33	0.065.1140.0	3	special bushing 59X55X20
34	2.3179.012.0	1	plug 60
35	2.3130.001.1	9	plug 1/8" gas
36	2.3130.002.1	2	plug 1/4" gas
37	2.3130.003.1	7	plug 3/8" gas
38	2.3199.092.0	3	plug 8 x 12

**CRANKCASE**

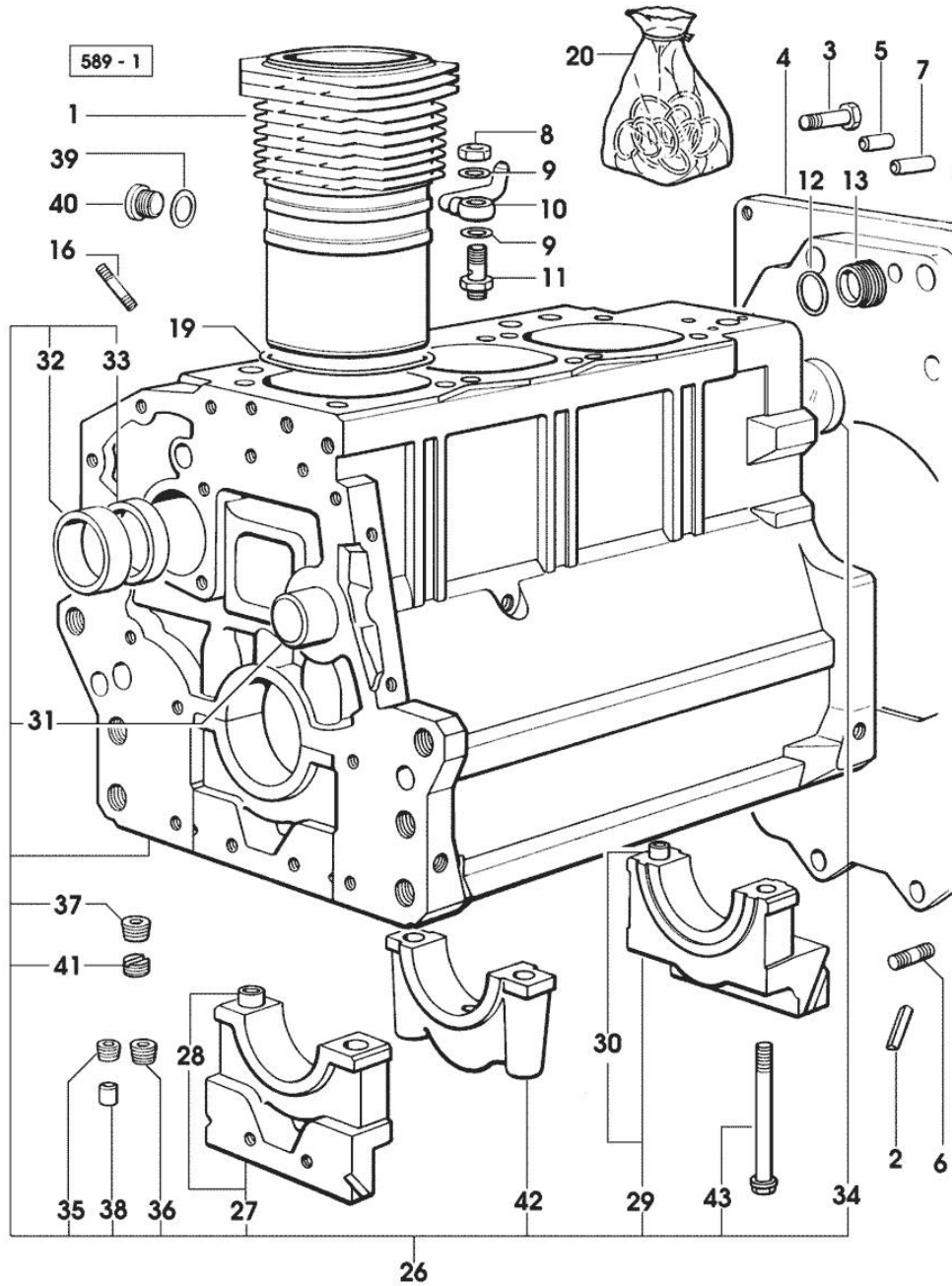
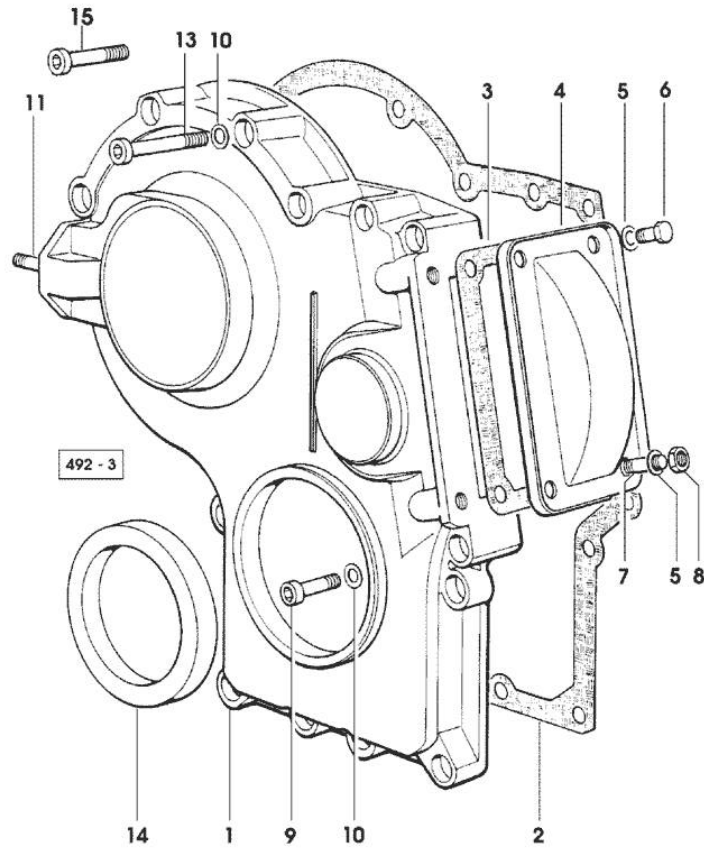

Fig.	P/n	QTY	Name
39	2.1560.017.0	1	gasket 22.2 x 27
40	2.3120.002.4	1	plug m 22 x 1.5 2415 <= X CRONO 554-50 2051 <= X CRONO 564-60 3925 <= X CRONO 574-70
41	2.1324.011.0	1	plug
42	0.065.1114.0/10	2	support
43	0.065.1117.0	8	screw m 12 x 100

Section: ENGINE  
TIMING CASE

Fig.	P/n	QTY	Name
------	-----	-----	------

Notes:  
[CRONO 564-60]



1	0.065.1132.0/60	1	guard
2	0.065.1150.0/30	1	gasket
3	0.065.1152.0	1	gasket
4	0.065.1151.0	1	cover
5	2.1470.004.2	4	lock washer 8
6	2.0112.205.2	2	screw m 8 p.1.25 x 16
7	2.0432.003.7	2	stud bolt m 8 p.1.25 / p.1 x 20
8	2.1011.405.2	2	nut m 8 p.1
9	2.0312.208.2	8	screw m 8 p.1.25 x 25
10	2.1480.014.1	15	washer 8
11	2.0432.003.7	2	stud bolt m 8 p.1.25 / p.1 x 20
13	2.0312.214.1	3	screw m 8 p.1.25 x 40
14	2.1529.141.0	1	special oil seal
15	2.0312.219.2	4	screw m 8 p.1.25x65

Section: ENGINE

**CRANKSHAFT**

Fig.	P/n	QTY	Name
------	-----	-----	------

Notes:  
[CRONO 564-60]

1	0.007.1554.0/20	1	crankshaft
2	2.3130.001.1	3	plug 1/8" gas
5	0.078.1220.3/30	3	engine connecting rod
6	2.0399.213.0	6	screw m 12 p.1.25x61.5
7	2.1559.114.0/10	3	special bushing
8	2.1411.014.1	6	circlip 35
9	0.078.1236.0	3	piston pin Ø 18 / Ø 35 / L = mm 86
10	2.1720.006.0	2	key 4x6.5
11	0.085.1248.0/10	1	hub
12	2.1589.189.0	3	shoulder ring mm 1.00
13	2.0399.144.7/10	1	screw m 20 p.1.5x51
14	2.1599.524.7	1	washer 21x60x12
17	0.007.1330.0/30	1	pulley
18	0.065.1254.0/20	1	gasket
19	0.007.1711.0/10	1	cover
20	2.1529.073.0	1	special oil seal 110x130x13
21	2.0112.207.2	9	screw m 8 p 1.25 x 20
22	2.1475.002.2	9	conical washer 8
23	0.065.1225.0	6	con.rod half bushing STANDARD - A = 28.75 -> 29.00
23	0.065.1225.7		con.rod half bushing - mm 0.25
23	0.065.1225.8		con.rod half bushing - mm 0.50
24	0.065.1215.0	4	main half bushing STANDARD
24	0.065.1215.7		main half bushing - mm 0.25
24	0.065.1215.8		main half bushing - mm 0.50
25	0.065.1216.0	4	main half bushing
25	0.065.1216.7		main half bushing - mm 0.25
25	0.065.1216.8		main half bushing - mm 0.50
26	0.065.1218.0	4	shim STANDARD
26	0.065.1218.7		shim + mm 0.10
26	0.065.1218.8		shim + mm 0.15
27	0.086.0060.6/30	3	complete piston
27	0.338.0060.6/20	3	complete piston
27	0.379.0060.6	3	complete piston
27	0.381.0060.6	3	complete piston
28	0.086.0052.6/10	1	piston ring set

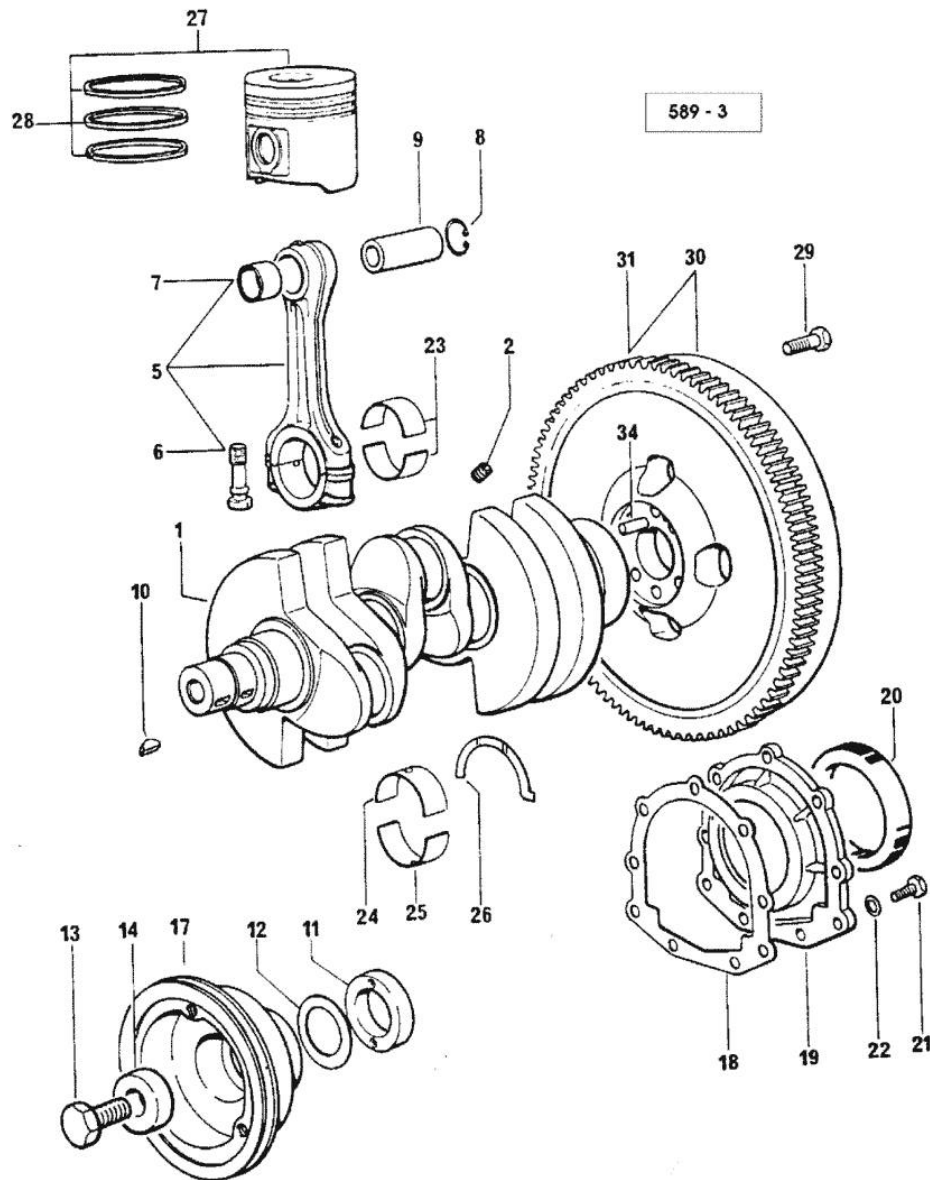

Section: ENGINE

CRANKSHAFT

Fig.	P/n	QTY	Name
			- X CRONO 554-50 - 564-60
28	0.338.0052.6	1	piston ring set
			- X CRONO 574-70
29	2.0119.174.0/10	6	screw m 12 p.1.25x45
30	0.007.1616.3/10	1	flywheel
			- X CRONO 554-50
30	0.007.1617.3/10	1	flywheel
			- X CRONO 564-60 - 574-70
31	0.069.1242.0	1	crown wheel Z = 121
34	2.1652.915.0	1	cylindrical plug 12x35

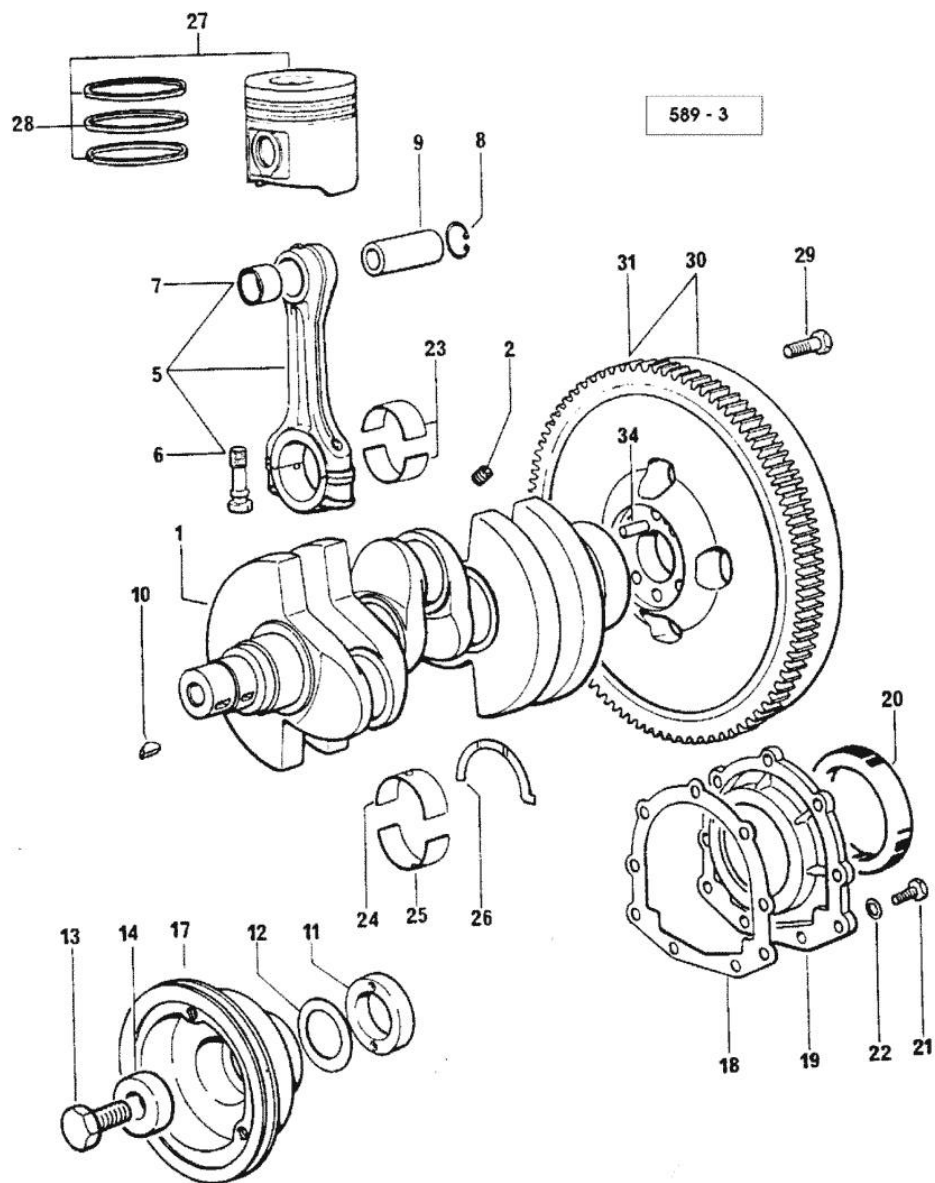

Section: ENGINE

**CAMSHAFT**

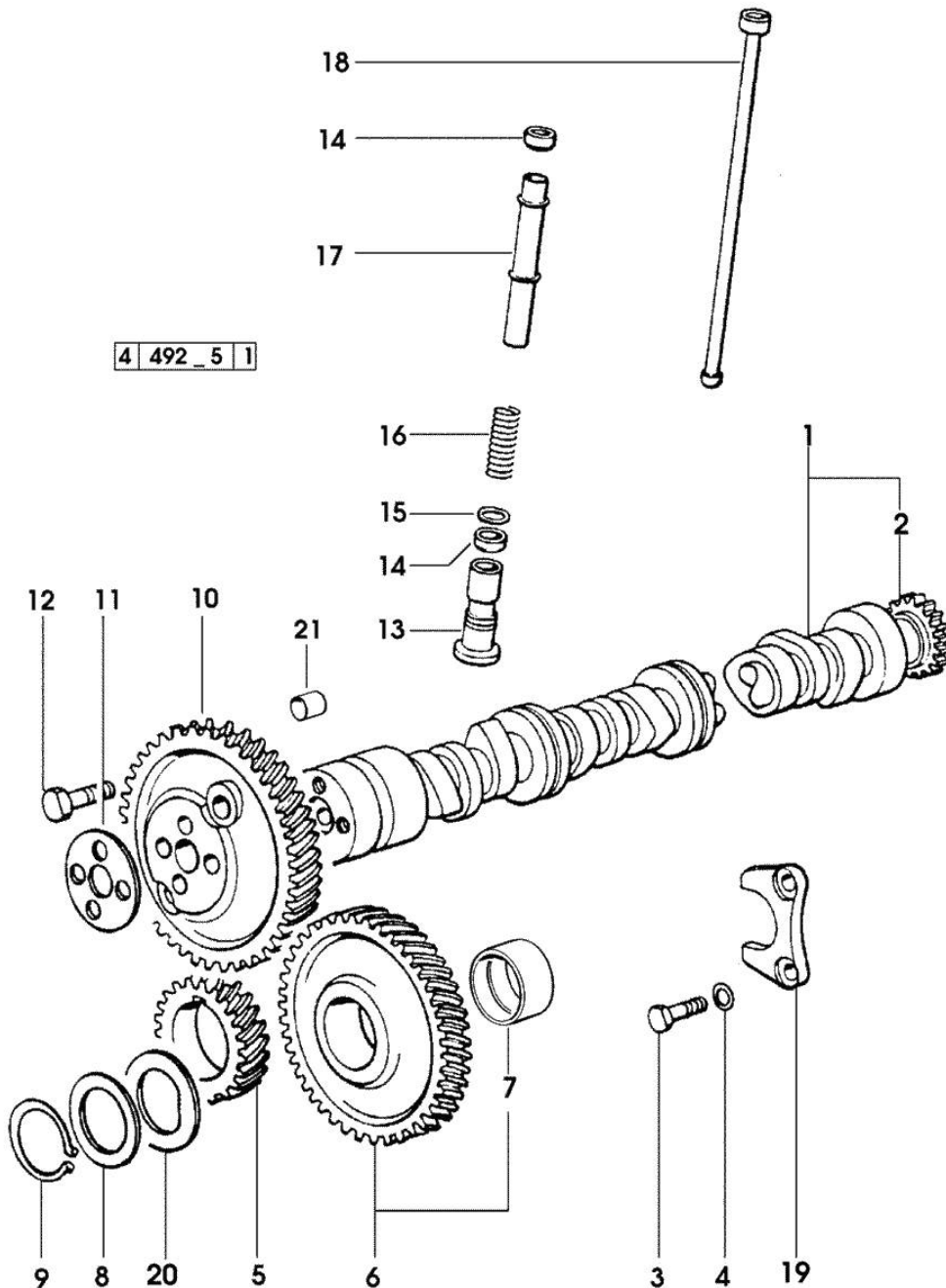

Fig.	P/n	QTY	Name
------	-----	-----	------

Notes:

[CRONO 564-60]

1	0.009.7456.3/10	1	camshaft - EXPORT U.S.A.
1	0.070.1310.3/40	1	camshaft
2	0.065.1324.0/10	1	gear Z = 32
3	2.0312.206.2	2	screw m 8 p 1.25 x 20
4	2.1480.014.1	2	washer 8
5	0.065.1323.0/30	1	gear Z = 29
6	0.007.1177.3/10		gear z = 57 - WITH RED IDENTIFICATION STAMP
6	0.007.1178.3/10		gear z = 57 - WITH YELLOW IDENTIFICATION STAMP
6	0.007.1179.3/10		gear z = 57 - WITH GREEN IDENTIFICATION STAMP
7	2.1559.185.0/10	1	bushing
8	0.065.1352.0	1	shim
9	2.1410.016.1	1	circlip 40
10	0.065.1354.0/20	1	gear z=58
11	0.065.1350.0	1	small disc
12	2.0132.207.2	4	screw m 10 p.1 x 25
13	0.065.1330.0	6	tappets
14	2.1569.114.0/10	12	gasket 14x18.5x8
15	2.1599.437.0	6	shoulder ring
16	2.4019.300.1/10	6	spring 18.5x52x2
17	0.065.1332.0	6	sleeve
18	0.065.1331.2	6	rod
19	0.065.1353.0	1	small plate
20	0.065.1351.0	2	shoulder ring
21	2.1559.398.0	1	bushing 10.5x13x12

Section: ENGINE  
CYLINDER HEAD

Fig.	P/n	QTY	Name
------	-----	-----	------

Notes:  
[CRONO 564-60]

1	2.0399.130.2	3	screw m 8 x 30 2798 <= X CRONO 554-50 2362 <= X CRONO 564-60 (...) <= X CRONO 574-70
1	2.0399.130.2/10	3	screw m 8x36x44 => 2799 X CRONO 554-50 => 2363 X CRONO 564-60 => (...) X CRONO 574-70
2	2.1569.170.0/10	3	gasket 8.2 x 14
3	0.007.1139.0/10	3	small cap * 2798 <= X CRONO 554-50 * 2362 <= X CRONO 564-60 * (...) <= X CRONO 574-70 - N.1 2.0399.130.2/10
5	2.1011.421.2	6	nut m 10 p.1.25
6	2.0432.163.7	6	stud bolt m 10 p.1.5 / p.1.25 x 45
7	0.066.1430.0/10	3	support
8	0.066.1432.0	6	rocker arm
9	2.1599.432.0	6	shoulder ring
10	2.1410.055.1	6	circlip 19
11	2.1011.405.2	2	nut m 8 p.1
12	0.021.1434.0	6	screw
13	0.074.1423.0	12	conical valve cotter
14	0.066.1425.0	6	cup
15	2.4019.287.0	6	spring
16	0.007.1122.0/10	3	bush L = mm 6,4
17	2.0432.161.7	3	stud bolt m 10 p.1.5 / p.1.25 x 40
18	0.065.1443.0/20	12	screw
19	0.085.0057.6		gasket set - FOR 1 CYLINDER VALVE GRINDING AND PISTON RINGS REPLACEMEN
20	2.0432.007.2	6	stud bolt m 8 p.1.25 / p.1 x 30
21	0.085.1450.0		head gasket mm 0.5 -A-
21	0.085.1451.0		head gasket mm 0.7 -B-
21	0.085.1452.0		head gasket mm 1.0 -C-
21	0.085.1453.0		head gasket mm 0.8 -D-
22	0.010.6022.0	3	exhaust valve mm 39.1 / Ø mm 9 - X CRONO 574-70 -> (...) = B
22	0.066.1421.0	3	exhaust valve - X CRONO 554-50 - 564-60 - X CRONO 574-70 (...) <- = A

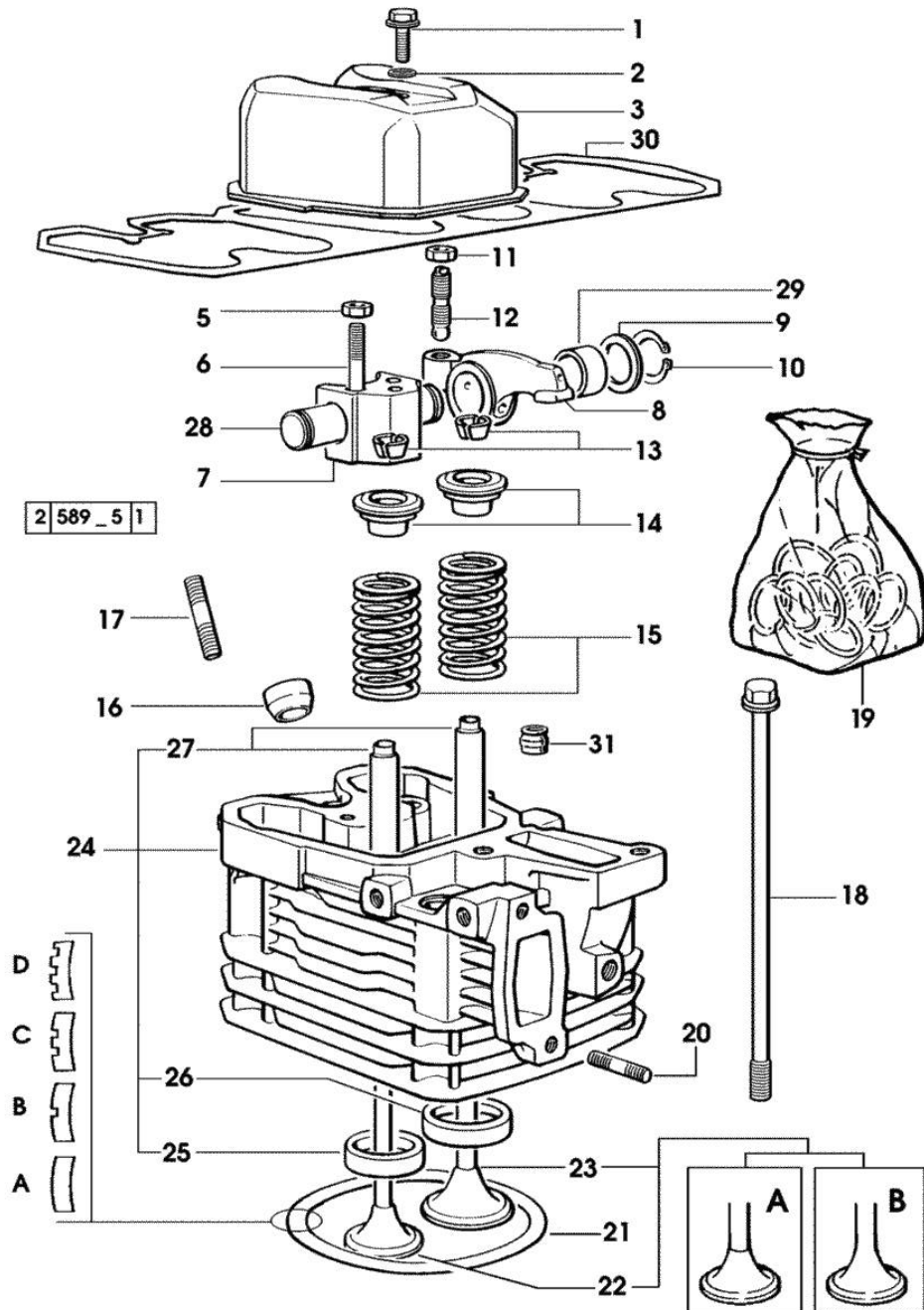

**Buy Now**



Our support email:

[ebooklibonline@outlook.com](mailto:ebooklibonline@outlook.com)