

Section: ENGINE
CRANKCASE

9_34811_00_0_A

Fig.	P/n	QTY	Name
------	-----	-----	------

Notes:
 [CRONO 564-65 F]

1	0.007.1150.6/10	1	crankcase
1.1	2.3130.001.1	9	plug 1/8" gas
1.2	2.3130.002.1	2	plug 1/4" gas
1.3	2.3130.003.1	7	plug 3/8" gas
1.4	2.1324.011.0	1	plug
1.5	2.3199.092.0	3	plug 8 x 12
1.6	2.3179.012.0	1	plug 60
1.12	0.000.0000.1		cannot be supplied
1.12.1	0.065.1112.7	1	support
1.12.1.2	2.1699.165.0	1	bush 12.3x15x16
1.12.2	0.065.1114.0/10	2	support
1.12.3	0.065.1116.3	1	support
1.12.3.2	2.1699.165.0	1	bush 12.3x15x16
1.12.4	0.065.1117.0	8	screw m 12 x 100
1.12.6	0.066.1151.0	1	pin
1.12.7	0.065.1141.0	1	special bushing 59X55X30
1.12.8	0.065.1140.0	3	special bushing 59X55X20
2	2.1539.130.0/10	3	special oil seal 117.07x3.53
4	2.0432.003.7	9	stud bolt m 8 p.1.25 / p.1 x 20
5	2.1532.072.0	1	oil seal 26.70x1.78
6	2.3199.405.2	1	plug m 28 p.1.5
7	0.066.1152.0/10	4	gasket

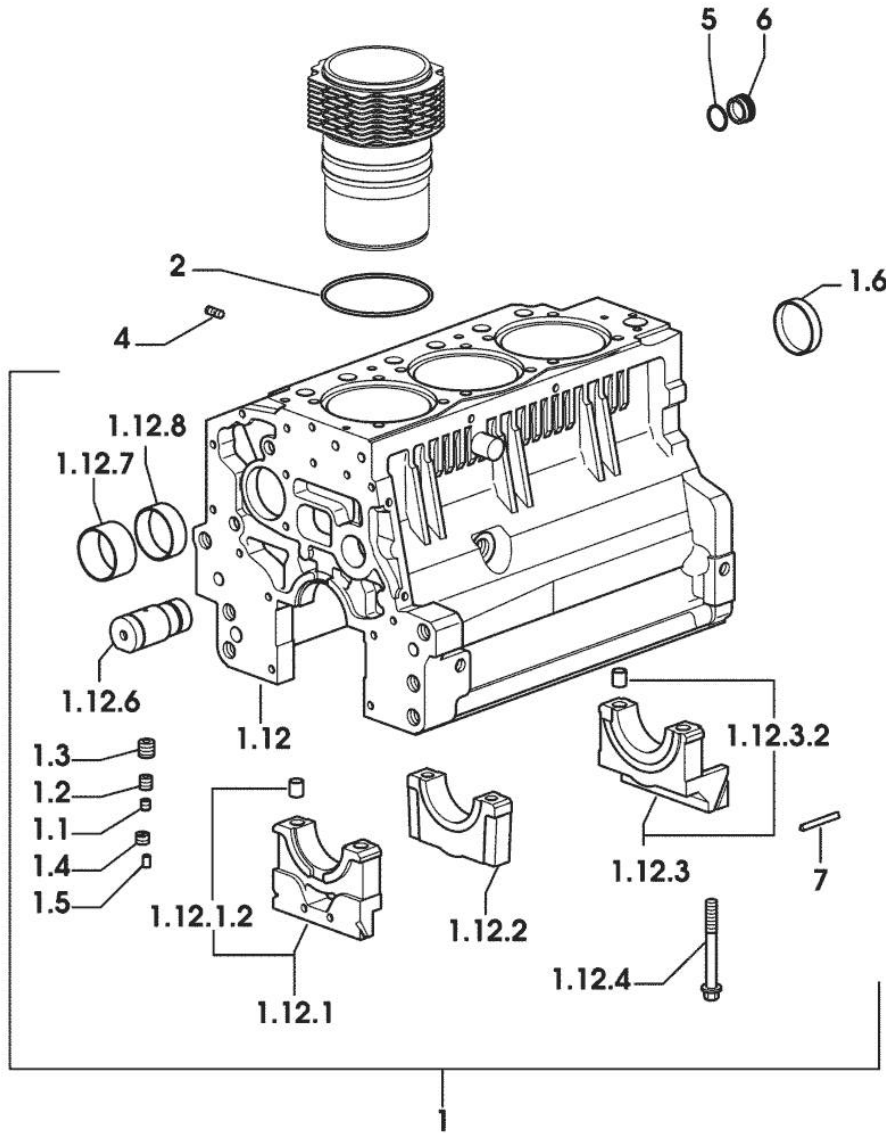

9_34811_00_0_B

Section: ENGINE

TIMING CASE

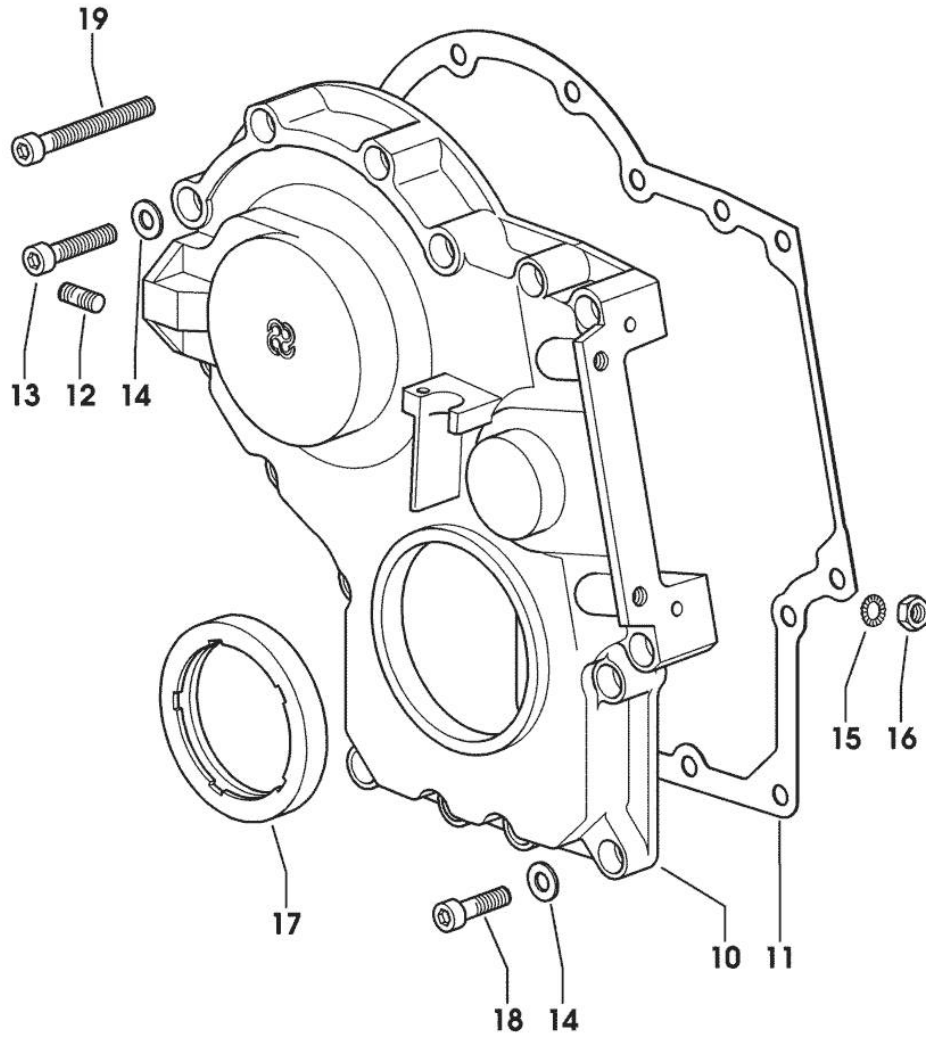

Fig.	P/n	QTY	Name
------	-----	-----	------

Notes:
[CRONO 564-65 F]

10	0.013.4981.0	1	guard
11	0.065.1150.0/30	1	gasket
12	2.0432.003.7	2	stud bolt m 8 p.1.25 / p.1 x 20
13	2.0312.214.2	3	screw m 8 p.1.25 x 40
14	2.1480.014.1	15	washer 8
15	2.1470.004.2	4	lock washer 8
16	2.1011.405.2	2	nut m 8 p.1
17	2.1529.141.0	1	special oil seal
18	2.0312.208.2	8	screw m 8 p.1.25 x 25
19	2.0312.219.2	4	screw m 8 p.1.25x65

MONOBLOC ENGINE-GEARBOX CONNECTING FLANGE

Fig.	P/n	QTY	Name
------	-----	-----	------

Notes:
[CRONO 564-65 F]

1	0.007.1882.0/50	1	flange
2	2.0112.511.2	8	screw m 14 p.2 x 30
3	2.1651.912.0	2	cylindrical plug 12x28
4	2.1651.917.0	1	cylindrical plug 12x40
5	2.0432.257.7	1	stud bolt m 12 p.1.75 - 1.25 x 30
6	2.0439.250.7	1	stud bolt m 12 / m 10 x 30
7	0.011.9294.0/10	1	bush

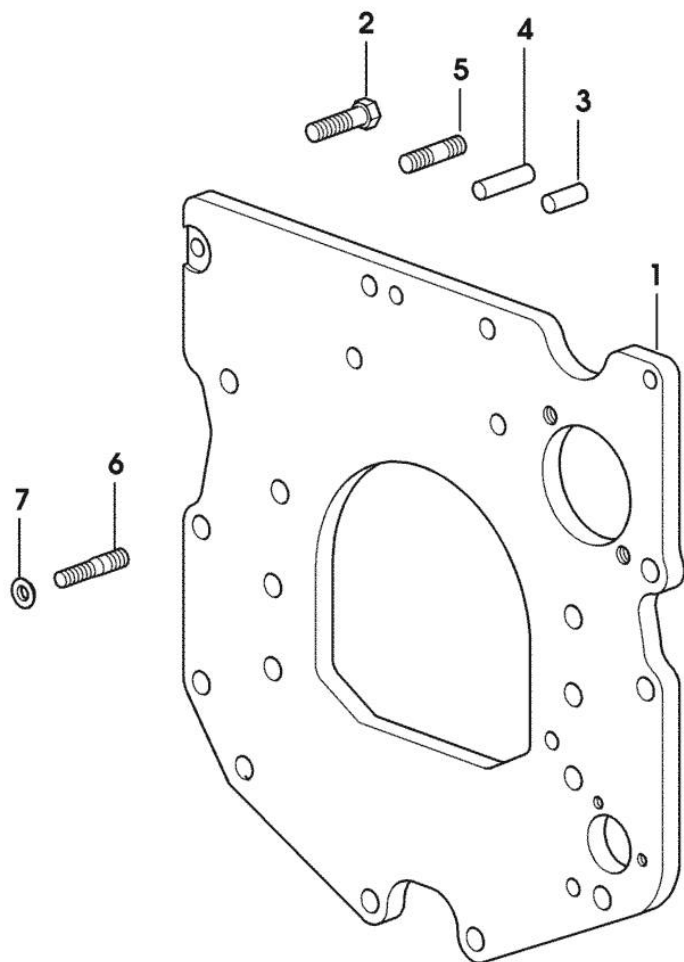

9_38611_01_0_0

Section: ENGINE
GUARD PLATE

Fig.	P/n	QTY	Name
------	-----	-----	------

Notes:
[CRONO 564-65 F]

1	0.007.1262.3/50	1	guard
2	0.007.1271.0/10	1	small column m 8 p.1.25 / L = mm 60
3	0.007.1272.0/10	2	small column m 8 p.1.25 / L = mm 50
5	2.1310.004.2	3	flat washer 8.4x17
7	2.0112.203.2	3	screw m 8 p.1.25 x 12

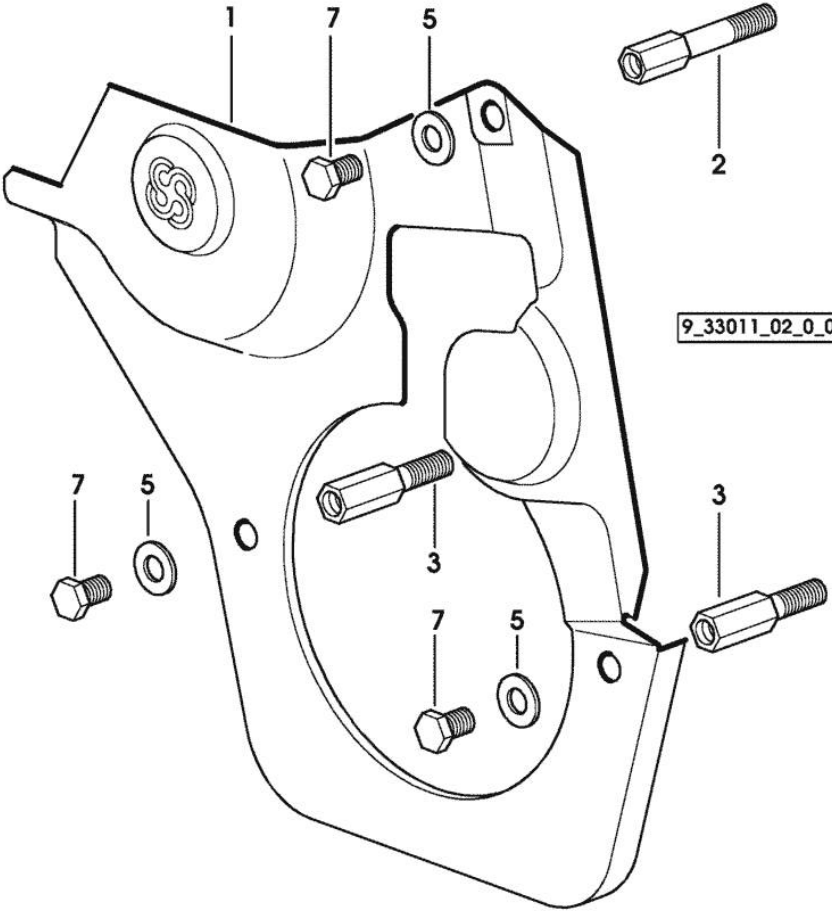

Section: ENGINE

CRANKSHAFT

9_34812_00_0_0

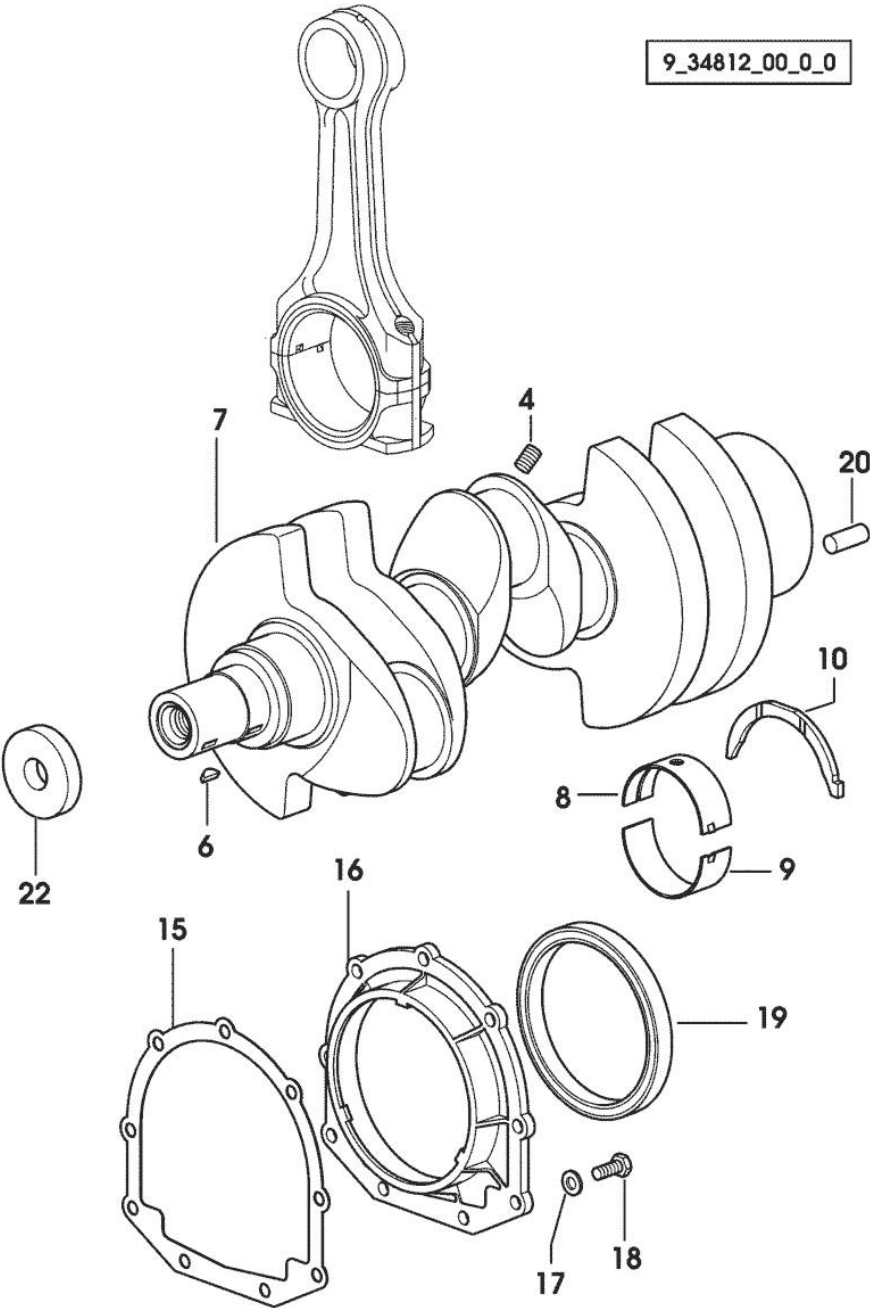

Fig.	P/n	QTY	Name
------	-----	-----	------

Notes:
 [CRONO 564-65 F]

4	2.3130.001.1	3	plug 1/8" gas
6	2.1720.006.0	2	key 4x6.5
7	0.007.1554.0/20	1	crankshaft
8	0.065.1215.0	4	main half bushing STANDARD
8	0.065.1215.7		main half bushing - mm 0.25
8	0.065.1215.8		main half bushing - mm 0.50
9	0.065.1216.0	4	main half bushing
9	0.065.1216.7		main half bushing - mm 0.25
9	0.065.1216.8		main half bushing - mm 0.50
10	0.065.1218.0	4	shim STANDARD
10	0.065.1218.7		shim + mm 0.10
10	0.065.1218.8		shim + mm 0.15
15	0.065.1254.0/20	1	gasket
16	0.007.1711.0/10	1	cover
17	2.1475.002.2	9	conical washer 8
18	2.0112.207.2	9	screw m 8 p 1.25 x 20
19	2.1529.073.0	1	special oil seal 110x130x13
20	2.1651.915.0	1	pin 12x35
22	2.1599.524.7	1	washer 21x60x12

Section: ENGINE

CRANKSHAFT PULLEY

Fig.	P/n	QTY	Name
------	-----	-----	------

Notes:
[CRONO 564-65 F]

1	0.007.1330.0/30	1	pulley
2	2.1589.189.0	2	shoulder ring mm 1.00
3	0.085.1248.0/10	1	hub
4	2.0399.144.7/10	1	screw m 20 p.1.5x51
6	2.1720.006.0	1	key 4x6.5

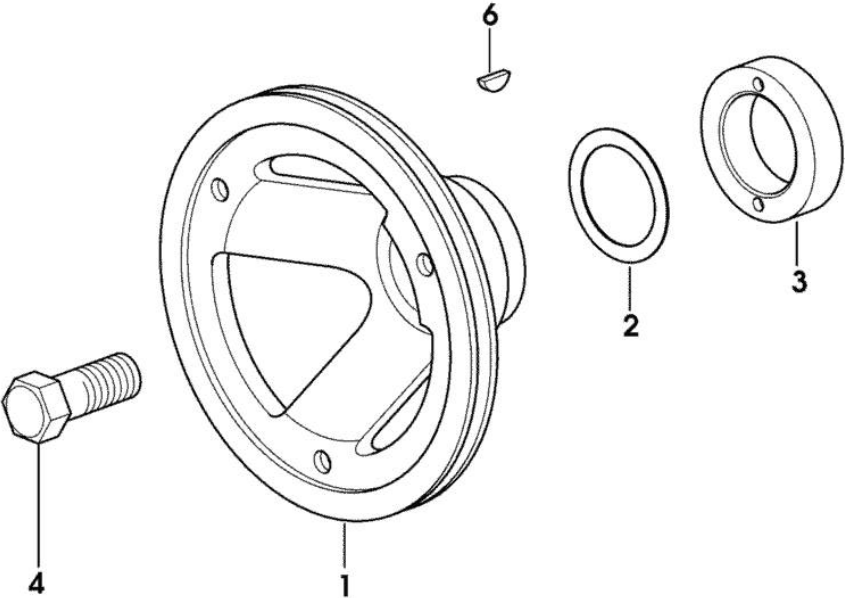

9_33012_02_0_0

Section: ENGINE

FLYWHEEL

Fig.	P/n	QTY	Name
------	-----	-----	------

Notes:
[CRONO 564-65 F]

1	0.007.1617.3/30	1	flywheel
1.2	0.069.1242.0	1	crown wheel Z = 121
2	2.0119.174.0/10	6	screw m 12 p.1.25x45
3	2.2041.008.0	1	ball bearing 20x47x14

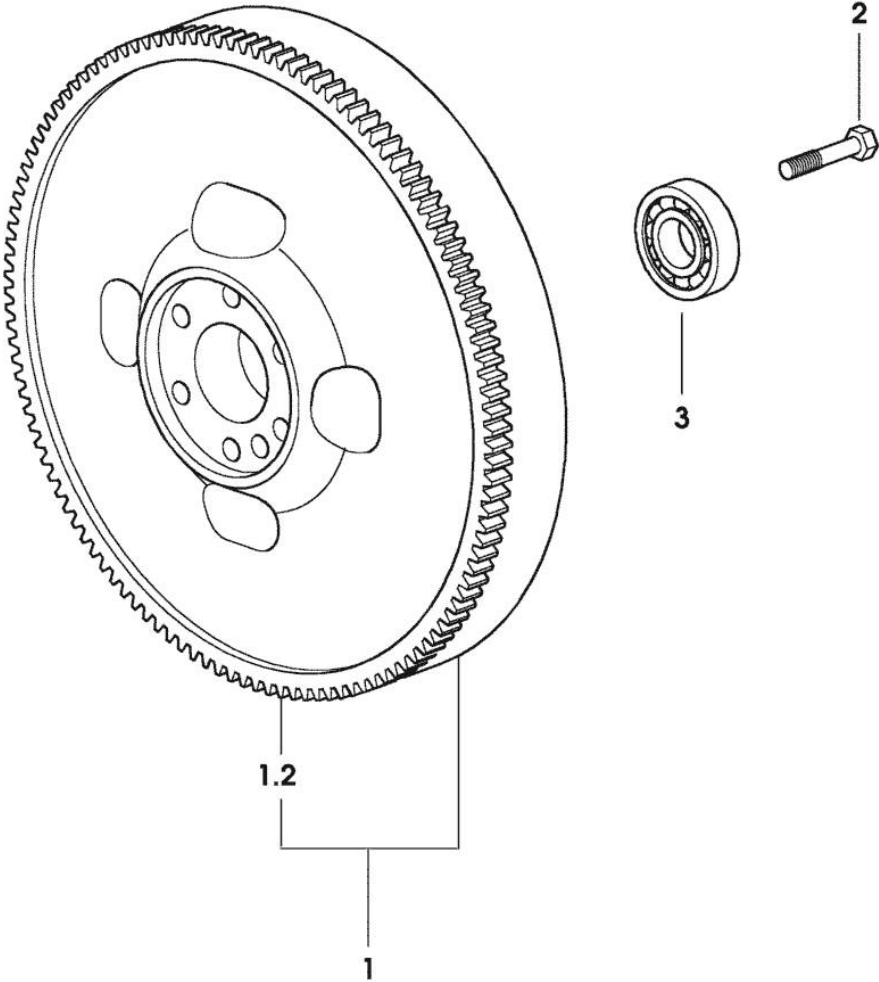

9_31112_02_0_0

Buy Now



Our support email:

ebooklibonline@outlook.com