

Section: ENGINE
CRANKCASE

Fig.	P/n	QTY	Name
------	-----	-----	------

Notes:
[EXPLORER 70]

0	0.065.0050.6	1	gasket set FOR ENGINE ASSEMBLY 916.4 A
0	0.087.0050.6/10	1	gasket set FOR 1000.4A ENGINE ASSEMBLY
1	2.0312.219.2	2	screw m 8 p.1.25x65
2	2.1470.004.2	2	lock washer 8
3	0.065.1143.3	1	body 1175 <=
3	0.065.1143.3/10	1	body => 1176
4	2.6850.006.0	1	clamp 18-28 => 1175
4	2.6859.072.2	1	clamp => 1176
5	0.065.1156.0	2	gasket
6	0.065.1155.0/10	1	tube 1175 <=
7	0.065.1157.0	1	bracket
8	2.1099.108.2	4	special nut m 10 p.1
9	2.1560.006.0	8	gasket 10.2 x 16
10	0.086.1550.2	4	sprayer nozzle
11	0.065.1160.3/20	4	valve
12	2.1532.072.0	1	oil seal 26.70x1.78
13	2.3199.405.2	4	plug m 28 p.1.5
16	2.0432.003.7	12	stud bolt m 8 p.1.25 / p.1 x 20
19	2.1519.096.0/20	4	special oil seal 107.67x1.78 X 1000.4 A
19	2.1589.154.0	4	shoulder ring FOR 916.4 A ENGINE
19	2.1589.155.0	4	shoulder ring X 916.4 A
19	2.1589.156.0	4	shoulder ring
20	0.065.1120.0/10	4	engine cylinder X 916.4 A
20	0.085.1120.0/10	4	engine cylinder X 1000.4 A
21	2.0112.207.2	2	screw m 8 p 1.25 x 20
22	2.1470.004.2	2	lock washer 8
23	0.065.1163.0	1	flange
25	0.066.1152.0/10	4	gasket
26	9.06599.41.3	1	crankcase

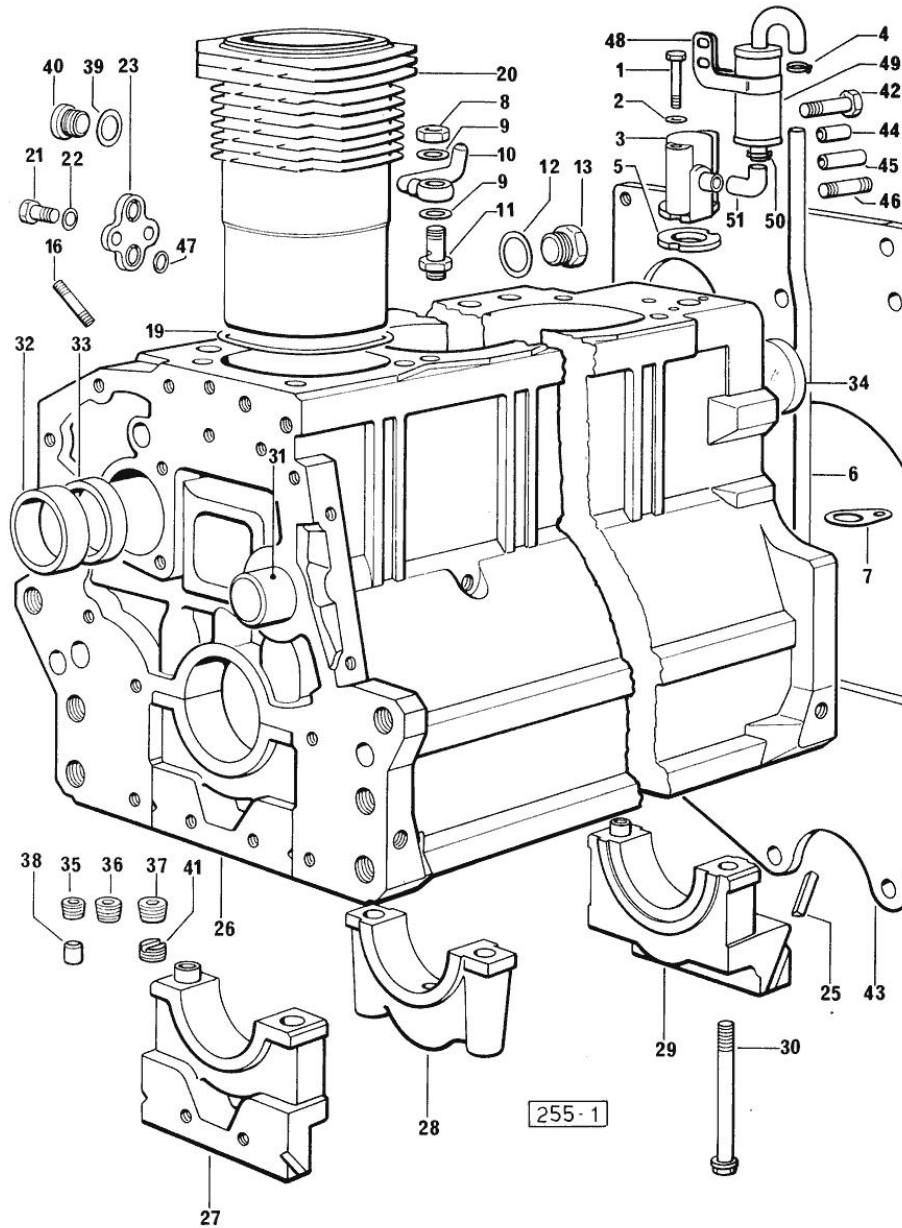

Section: ENGINE
CRANKCASE

Fig.	P/n	QTY	Name
			X 1000.4 A
27	0.065.1112.7/10	1	support
27	2.1699.165.0	1	bush 12.3x15x16
28	0.065.1114.0/10	3	support
29	0.065.1116.3	1	support
29	2.1699.165.0	1	bush 12.3x15x16
30	0.065.1117.0	10	screw m 12 x 100
30	2.3332.002.1	1	pipe union m 10 p.1.25
31	0.066.1151.0	1	pin
32	0.065.1141.0	1	special bushing 59X55X30
33	0.065.1140.0	4	special bushing 59X55X20
34	2.3179.012.0	1	plug 60
35	2.3130.001.1	10	plug 1/8" gas
36	2.3130.002.1	2	plug 1/4" gas
37	2.3130.003.1	7	plug 3/8" gas
38	2.3199.092.0	4	plug 8 x 12
39	2.1560.017.0	1	gasket 22.2 x 27
40	2.3120.002.4	1	plug m 22 x 1.5
41	2.1324.011.0	1	plug
42	2.0112.511.2	8	screw m 14 p.2 x 30
43	0.066.1130.0	1	flange
			2741 <=
43	0.066.1130.0/20	1	flange
			=> 2742
44	2.1651.912.0	2	cylindrical plug 12x28
45	2.1651.917.0	1	cylindrical plug 12x40
46	2.0432.255.7	2	stud bolt m 12 p.1.75-1.25x25
47	2.1539.048.0	2	special oil seal 20.35x1.78
48	2.6859.074.2	1	old part number
49	0.065.1165.2	1	sediment bowl
50	2.6859.073.2	2	clamp
51	0.065.1166.0	1	sleeve

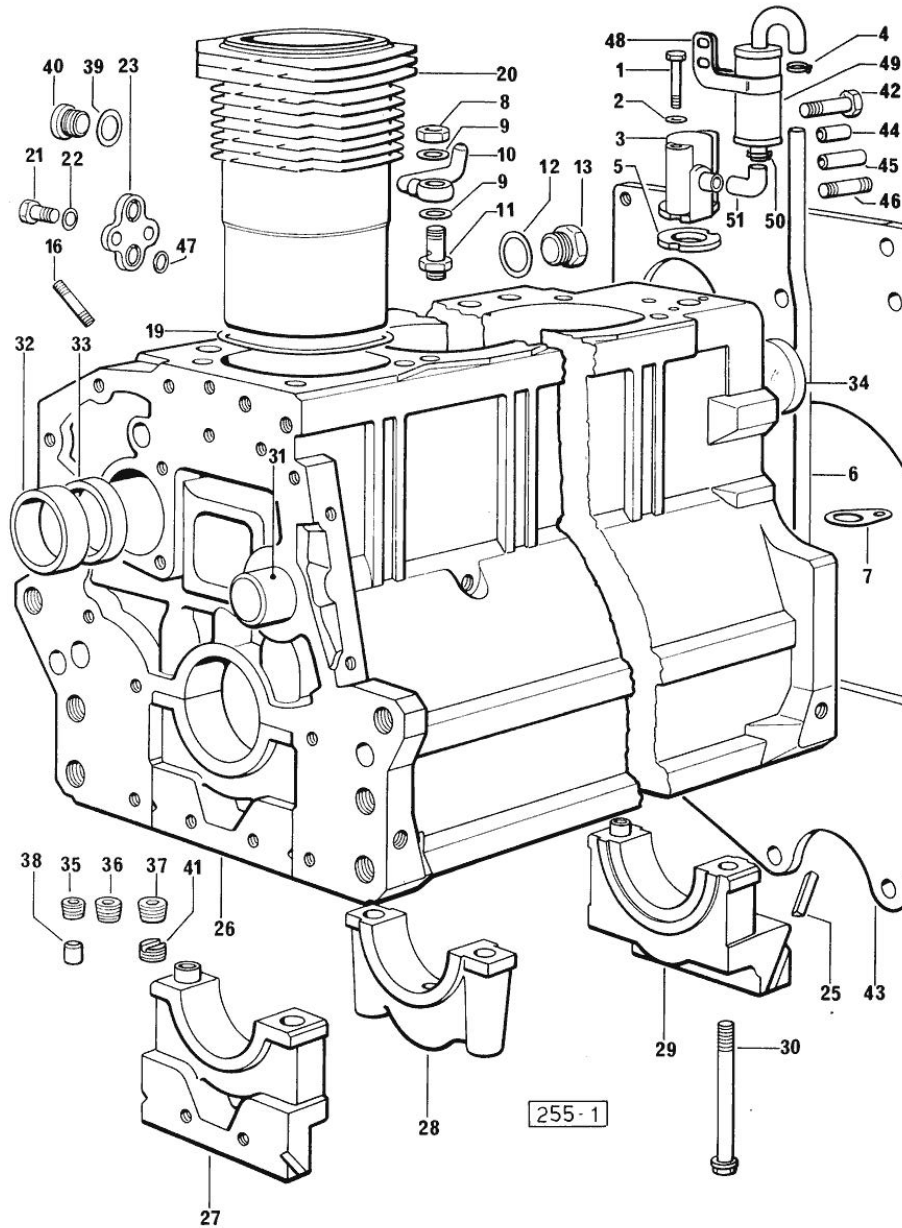

Section: ENGINE
TIMING CASE

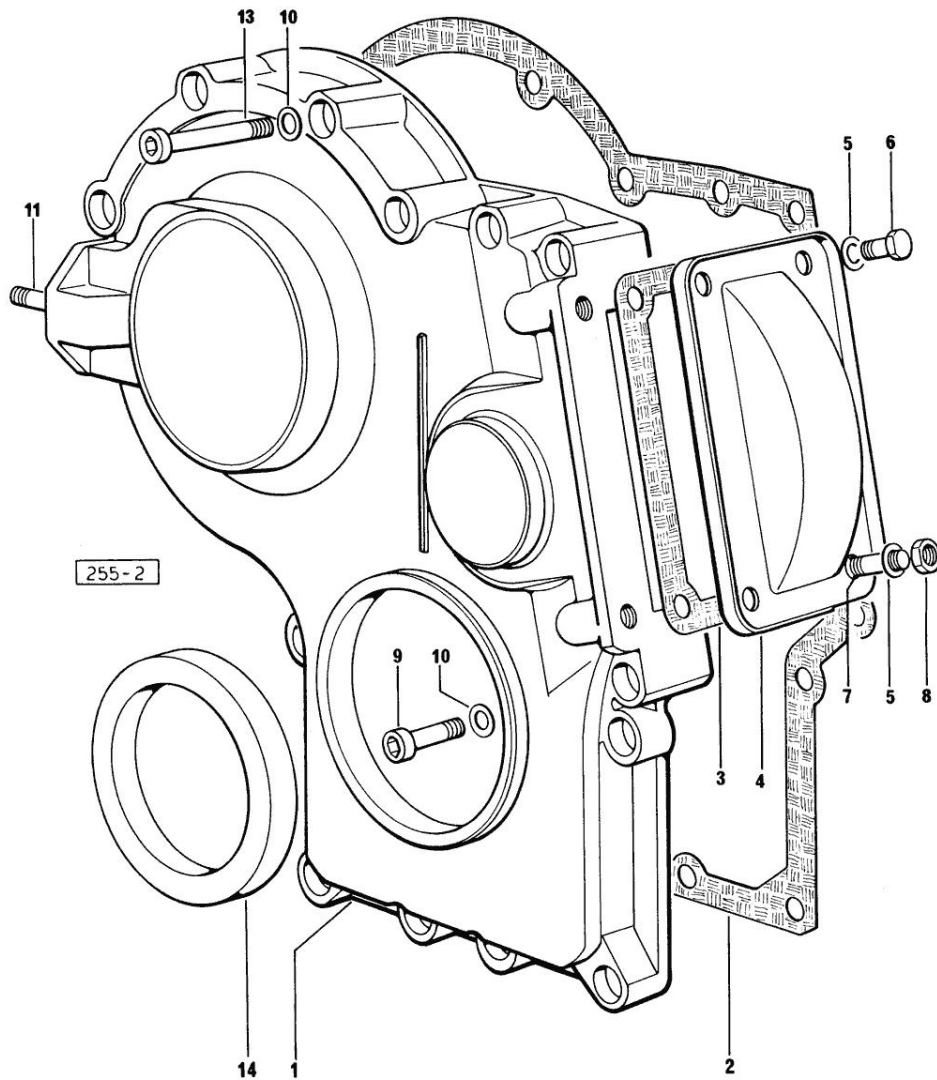

Fig.	P/n	QTY	Name
------	-----	-----	------

Notes:
[EXPLORER 70]

1	0.065.1132.0/20	1	guard
2	0.065.1150.0/30	1	gasket
3	0.065.1152.0	1	gasket
4	0.065.1151.0	1	cover
5	2.1470.004.2	4	lock washer 8
6	2.0112.205.2	2	screw m 8 p.1.25 x 16
7	2.0432.001.7	2	stud bolt m 8 p.1.25 - 1.00 x 16
8	2.1011.405.2	2	nut m 8 p.1
9	2.0312.208.2	8	screw m 8 p.1.25 x 25
10	2.1480.014.1	15	washer 8
11	2.0432.003.7	2	stud bolt m 8 p.1.25 / p.1 x 20
13	2.0312.214.2	3	screw m 8 p.1.25 x 40
13	2.0312.219.2	4	screw m 8 p.1.25x65
14	2.1529.167.0	1	oil seal

Section: ENGINE

CRANKSHAFT

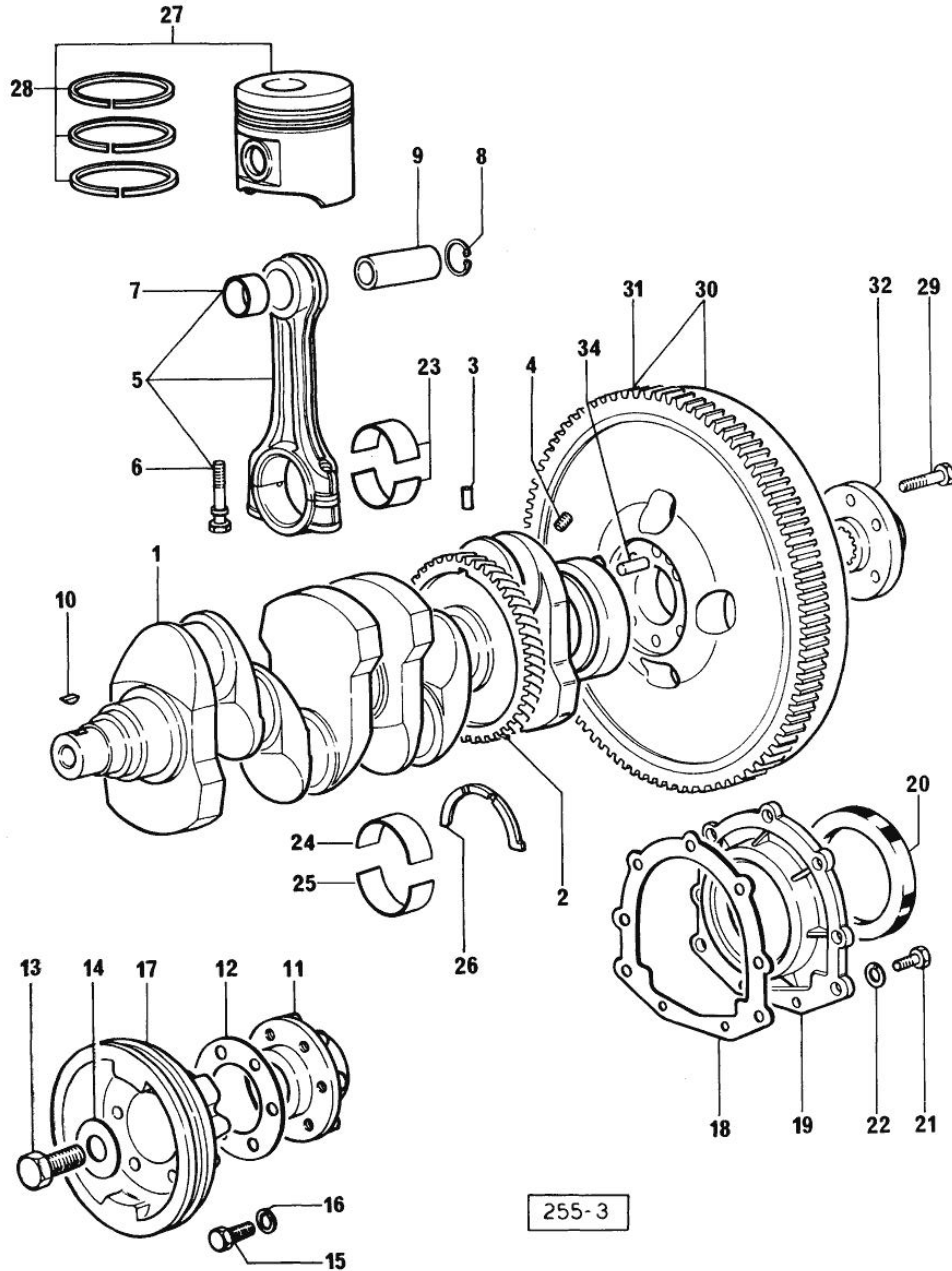

Fig.	P/n	QTY	Name
Notes:			
[EXPLORER 70]			
1	0.066.1210.3/20	1	crankshaft X 916.4 A => 3489
2	0.065.1211.0/10	1	crown wheel
3	2.1630.608.0	1	pin 6x16 X 1000.4 A
3	2.1630.611.0	1	roll pin 6 x 24 FOR 916.4 A ENGINE
4	2.3130.001.1	4	plug 1/8" gas
5	0.065.1220.3/30	4	engine connecting rod FOR 916.4 A ENGINE
5	0.078.1220.3/30	4	engine connecting rod X 1000.4 A
6	2.0399.213.0	8	screw m 12 p.1.25x61.5
7	0.065.1227.0	4	special bushing FOR 916.4 A ENGINE
7	2.1559.114.0/10	4	special bushing X 1000.4 A
8	2.1411.013.7	8	circlip Ø 32 FOR 916.4 A ENGINE
8	2.1411.014.1	8	circlip 35 X 1000.4 A
9	0.065.1236.0	4	piston pin FOR 916.4 A ENGINE
9	0.078.1236.0	4	piston pin Ø 18 / Ø 35 / L = mm 86 X 1000.4 A
10	2.1720.006.0	2	key 4x6.5
11	0.065.1248.0/40	1	hub
12	2.1589.136.0	1	shoulder ring 71x110x0.5
12	2.1589.137.0	1	shoulder ring 71x110x1
13	2.0399.095.2/10	1	screw
14	2.1599.503.2	1	shoulder ring
15	2.0112.317.2	6	screw m 10 p.1.5 x 45
16	2.1470.006.2	6	lock washer 10
17	0.065.1244.0/20	1	pulley
18	0.065.1254.0/20	1	gasket
19	0.065.1253.0/20	1	cover
20	2.1529.073.0	1	special oil seal 110x130x13
21	2.0112.207.2	9	screw m 8 p 1.25 x 20
22	2.1474.009.2	9	spring washer 8
23	0.065.1225.0	8	con.rod half bushing STANDARD - A = 28.75 -> 29.00
23	0.065.1225.7	8	con.rod half bushing - mm 0.25

Section: ENGINE

CRANKSHAFT

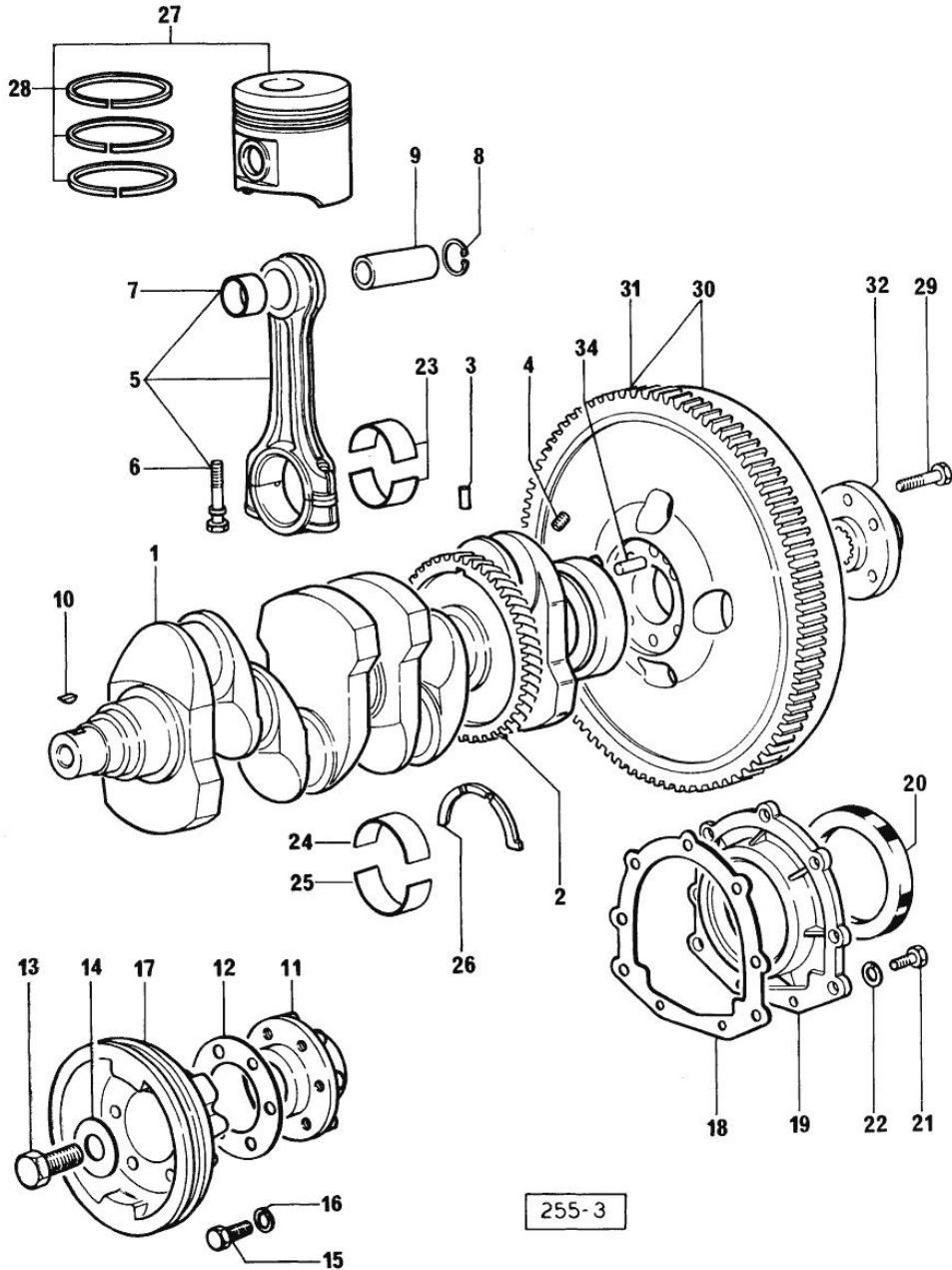

Fig.	P/n	QTY	Name
23	0.065.1225.8	8	con.rod half bushing - mm 0.50
24	0.065.1215.0/10	5	main half bushing STANDARD
24	0.065.1215.7	5	main half bushing - mm 0.25
24	0.065.1215.8	5	main half bushing - mm 0.50
25	0.065.1216.0/10	5	main half bushing STANDARD
25	0.065.1216.7	5	main half bushing - mm 0.25
25	0.065.1216.8	5	main half bushing - mm 0.50
26	0.065.1218.0	4	shim STANDARD
26	0.065.1218.7	4	shim + mm 0.10
26	0.065.1218.8	4	shim + mm 0.15
27	0.069.0060.6	4	complete piston STANDARD FOR 916.4 A ENGINE
27	0.086.0060.A	4	complete piston "A" X 1000.4 A
28	0.069.0052.6	4	piston ring set FOR 916.4 A ENGINE
28	0.086.0052.6/10	4	piston ring set X 1000.4 A
29	2.0139.022.2	6	screw m 12 p.1.25x55
30	0.065.1247.3/30	1	flywheel
31	0.065.1242.0	1	crown wheel Z = 123
32	0.255.2525.0/10	1	flange
34	2.1651.915.0	1	pin 12x35

Section: ENGINE
COUNTERWEIGHTS

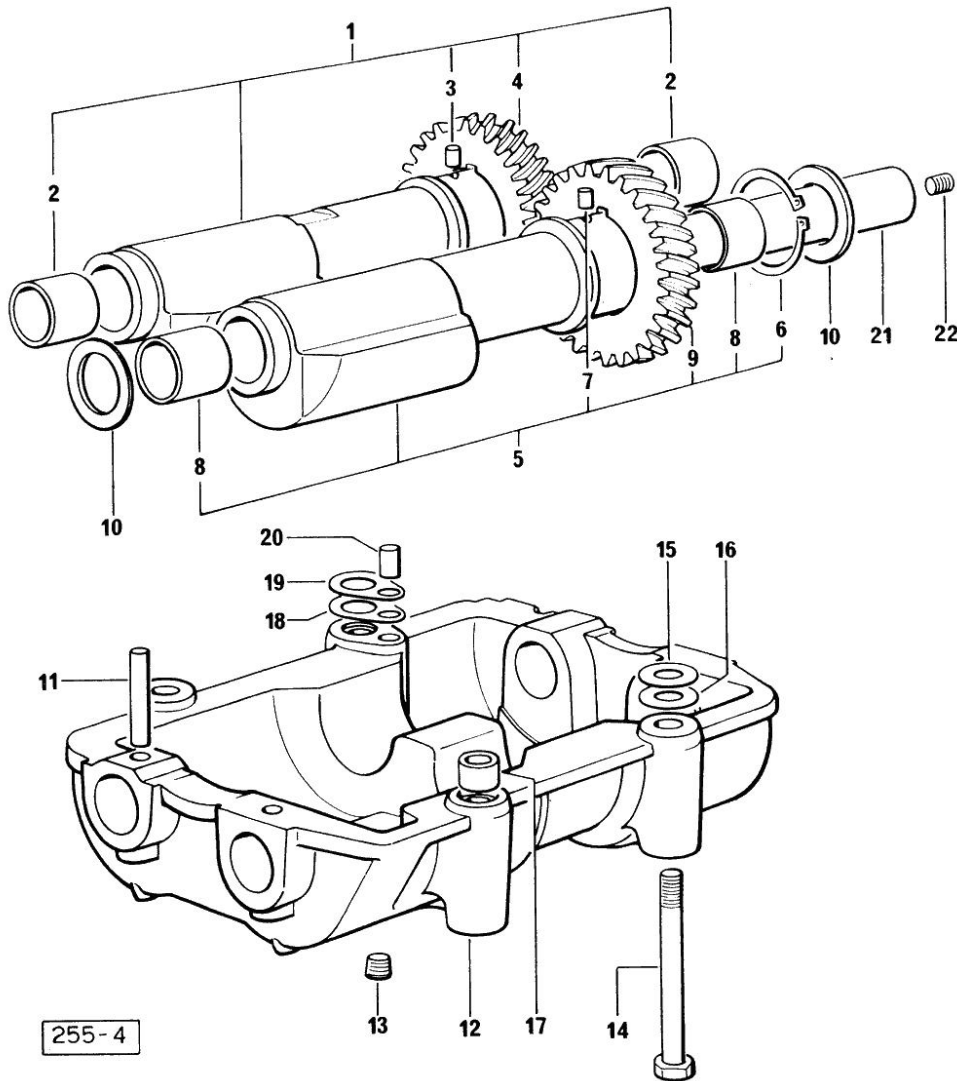

Fig.	P/n	QTY	Name
------	-----	-----	------

Notes:
 [EXPLORER 70]

1	0.086.1233.3/30	1	mass sx/lh/li FOR 916.4 A ENGINE
2	2.1559.115.0	2	special bushing 26x30x30
3	2.1651.302.0	1	roll pin 4x6
4	0.086.1233.3/30	1	mass sx/lh/li
5	0.065.1233.3/30	1	mass dx/rh/re
6	2.1410.018.7	1	circlip 45
7	2.1651.302.0	1	roll pin 4x6
8	2.1559.115.0	2	special bushing 26x30x30
9	0.065.1233.3/30	1	mass dx/rh/re
10	2.1589.050.0/10	4	shoulder ring 26.1x38x1 FOR 916.4 A ENGINE
10	2.1589.185.0	4	shoulder ring 26.1x34x1 X 1000.4 A
11	2.1631.717.0	2	roll pin 8 x 40
12	0.086.1231.0/10	1	box FOR 916.4 A ENGINE
13	2.3130.001.1	4	plug 1/8" gas
14	2.0112.427.2	3	screw m 12 p.1.75 x 90
15	2.1589.048.0	2	shoulder ring 16.5x26x0.3
15	2.1589.049.0	2	shoulder ring 12.5x26x0.3
16	2.1579.628.0	2	spacer 16.5x26x0.1
16	2.1579.629.0	2	spacer 12.5x26x0.1
17	2.1579.626.0	2	spacer 13.2x16x11
18	2.1589.139.0	2	shoulder ring mm 0.3
19	2.1589.140.0	2	shoulder ring mm 0.1
20	2.1699.191.0	1	bush 7x10x16
21	0.065.1234.3	2	old part number
22	2.3130.001.1	2	plug 1/8" gas

Section: ENGINE

CAMSHAFT

Fig.	P/n	QTY	Name
------	-----	-----	------

Notes:
[EXPLORER 70]

1	0.065.1324.0/10	1	gear Z = 32
1	0.066.1310.3/40	1	camshaft
2	0.065.1353.0	1	small plate
3	2.0312.206.2	2	screw m 8 p 1.25 x 20
4	2.1480.014.1	2	washer 8
5	0.065.1323.0/30	1	gear Z = 29
6	0.007.1177.3/20	1	gear z = 57
6	2.1559.185.0/10	1	bushing
7	0.065.1351.0	2	shoulder ring
8	0.065.1352.0	1	shim
9	2.1410.016.1	1	circlip 40
10	0.013.5017.0	1	gear z=58
11	0.065.1350.0	1	small disc
12	2.0132.207.2	4	screw m 10 p.1 x 25
13	0.065.1330.0	8	tappets
14	2.1569.114.0/10	16	gasket 14x18.5x8
15	2.1599.437.0	8	shoulder ring
16	2.4019.300.1/10	8	spring 18.5x52x2
17	0.065.1332.0	8	sleeve
18	0.065.1331.2	8	rod

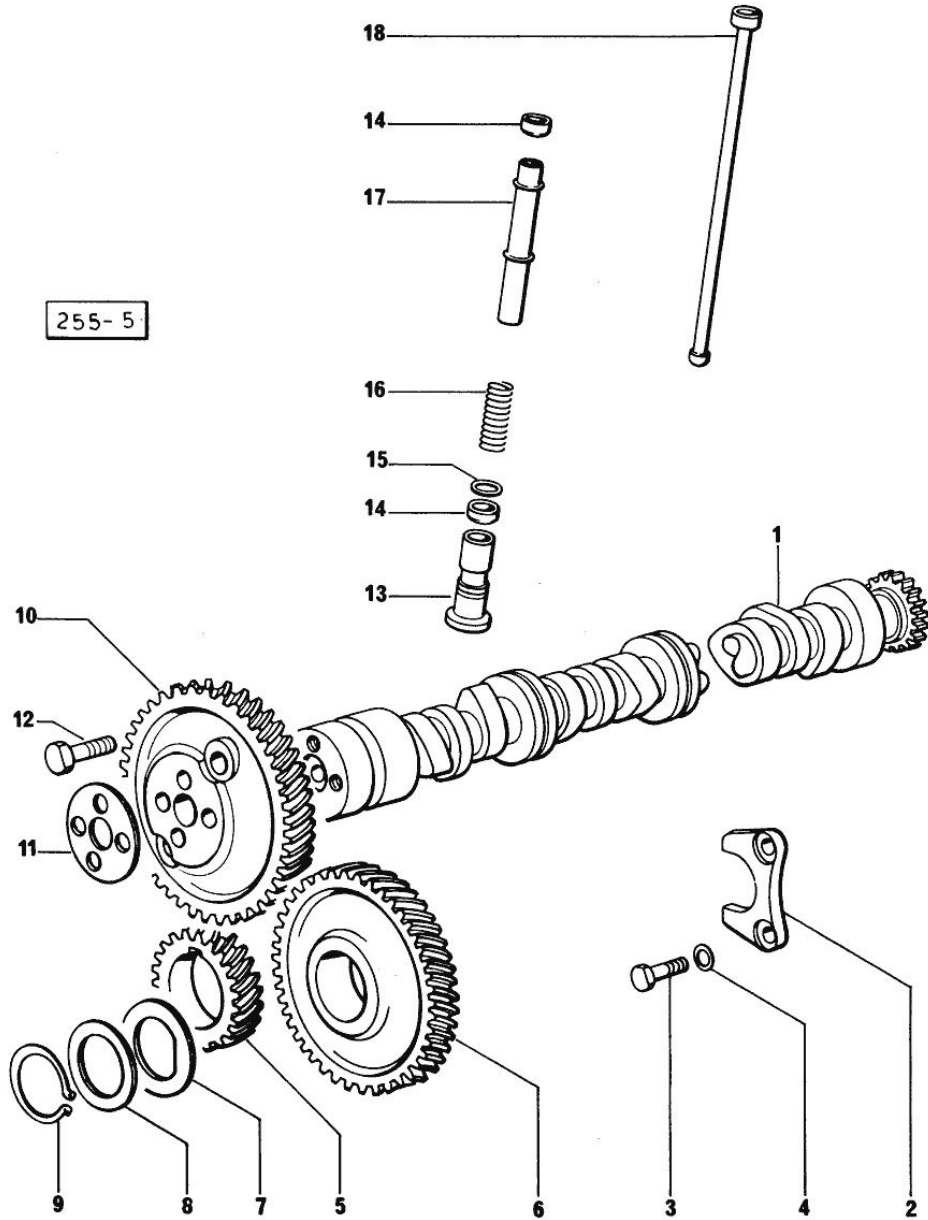

Buy Now



Our support email:

ebooklibonline@outlook.com