

LUBRICANTS AND SEALANTS

Fig.	P/n	QTY	Name
------	-----	-----	------

Notes:
[IRON 165.7 HI-LINE]

2	04414226	0.3	sealing compound HENKEL 211-342
3	04414225	0.01	genuine lubricants HENKEL 148785

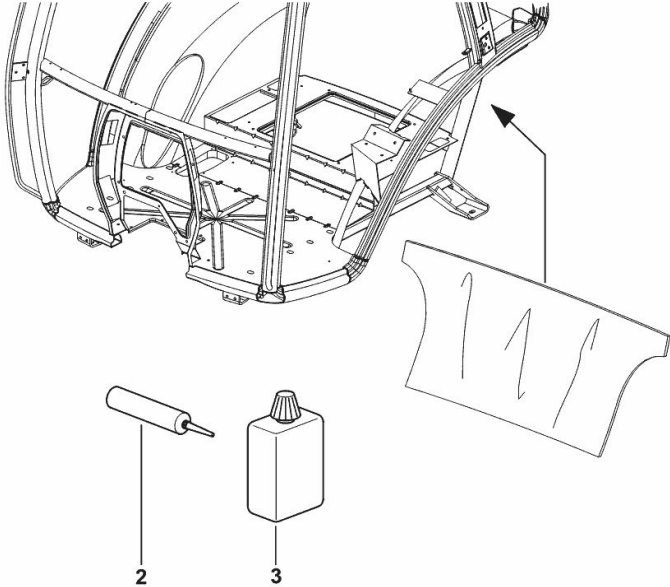

K9_95071_18_0-B-001

LUBRICANTS AND SEALANTS

Fig.	P/n	QTY	Name
------	-----	-----	------

Notes:

[IRON 165.7 HI-LINE]

2	04414226	0.12	sealing compound HENKEL 211-342
3	04414225	0.01	genuine lubricants HENKEL 148785
5	04414226	0.12	sealing compound HENKEL 211-342
6	04414225	0.01	genuine lubricants HENKEL 148785

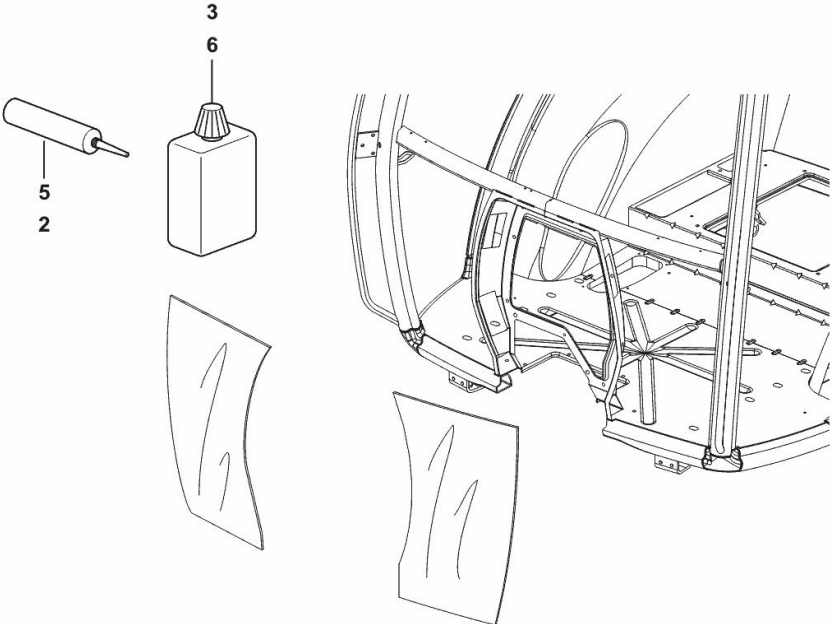

K9_95071_19_0-B-001

LUBRICANTS AND SEALANTS

Fig.	P/n	QTY	Name
------	-----	-----	------

Notes:
- FOR TYPES WITHOUT FRONT BRAKES [IRON 165.7 HI-LINE]

27	01005149	0.01	genuine lubricants H 685 -DEUTZ S2- 1 KG
28	01009463	0.05	sealing compound H 699 -DEUTZ DW 43

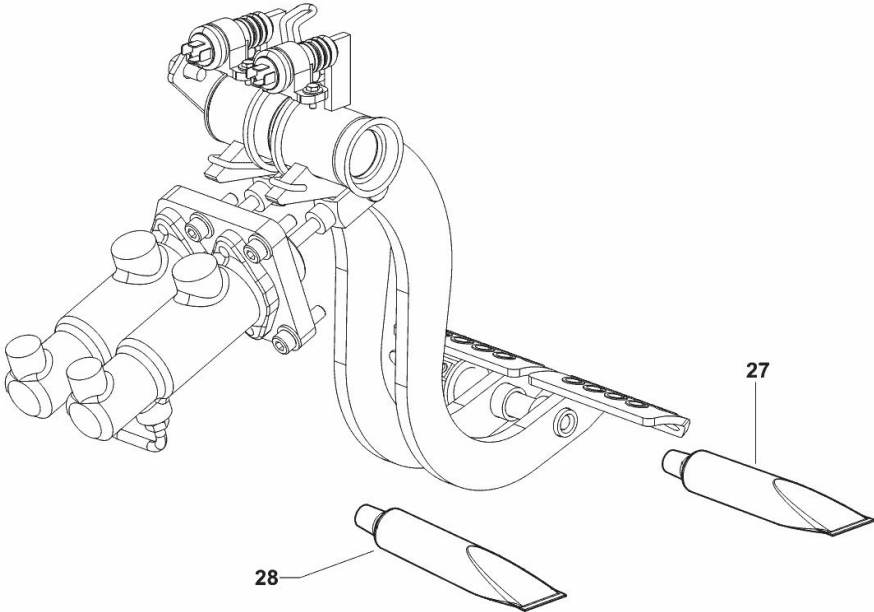

K9_F5066_00_0-C-001

LUBRICANTS AND SEALANTS

Fig.	P/n	QTY	Name
------	-----	-----	------

Notes:

WITHOUT SUSPENDED AXLE [IRON 165.7 HI-LINE]

6	01016130	0.01	sealing compound AS 450
---	----------	------	-------------------------

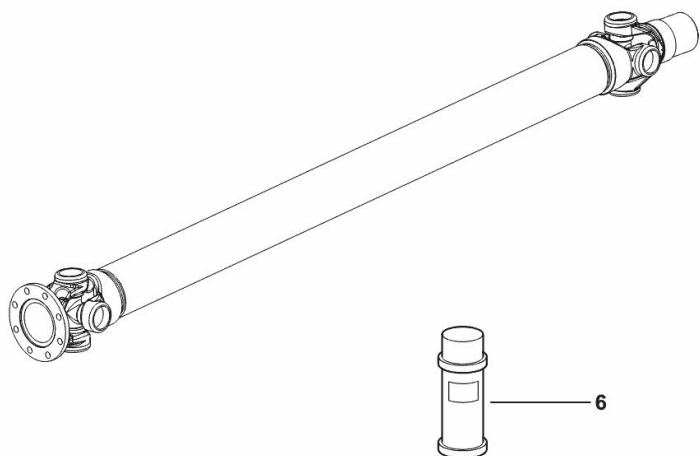

K9_A3626_00_0-B-001

LUBRICANTS AND SEALANTS

Fig.	P/n	QTY	Name
------	-----	-----	------

Notes:
- WITH SUSPENDED AXLE [IRON 165.7 HI-LINE]

6	01016130	0.01	sealing compound AS 450
---	----------	------	-------------------------

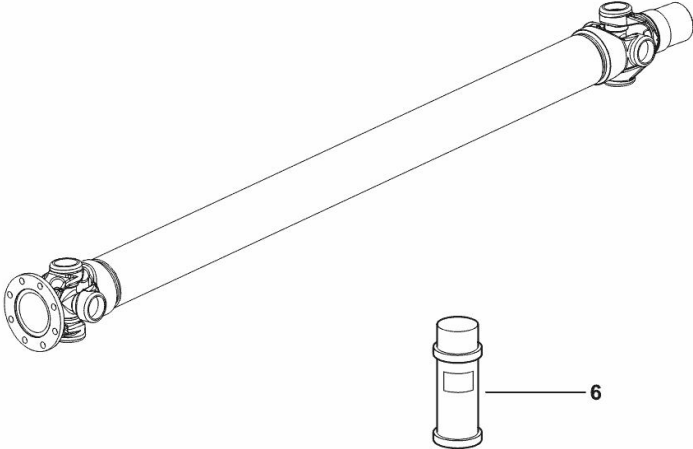

K9_A3626_01_0-B-001

LIQUID GASKET H 699 -DEUTZ DW 43

Fig.	P/n	QTY	Name
------	-----	-----	------

Notes:
- FOR TYPES WITH FRONT BRAKES [IRON 165.7 HI-LINE]

30	01009463	0.3	sealing compound H 699 -DEUTZ DW 43
----	----------	-----	-------------------------------------

K9_C7666_10_0-E-001

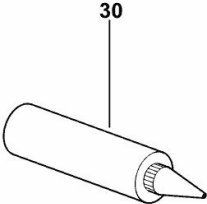

LIQUID GASKET H 699 -DEUTZ DW 43

Fig.	P/n	QTY	Name
------	-----	-----	------

Notes:
- FOR TYPES WITHOUT FRONT BRAKES [IRON 165.7 HI-LINE]

30	01009463	0.3	sealing compound H 699 -DEUTZ DW 43
----	----------	-----	-------------------------------------

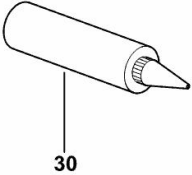

K9_D3666_10_0-D-001

Buy Now



Our support email:

ebooklibonline@outlook.com