

## Section: ENGINE

**CRANKCASE**

Fig.	P/n	QTY	Name
------	-----	-----	------

**Notes:**

[R 1156]

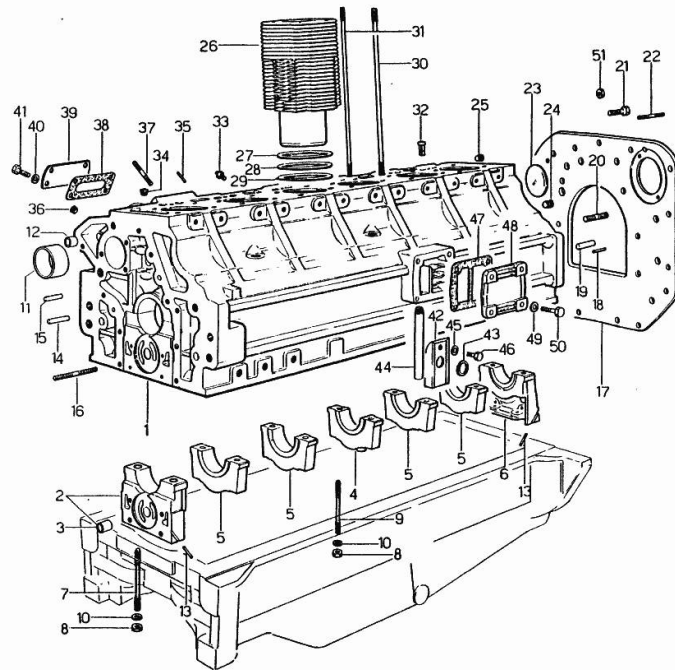

0	0.047.0050.6	1	gasket set
1	0.047.1110.4/50	1	crankcase
2	0.004.8774.3	1	support
3	2.1559.090.0/10	1	bushing 14.24x19.06x27
4	0.037.1114.0	1	support
5	0.029.1113.0	4	support
6	0.029.1116.0	1	support
7	0.021.1157.0	4	stud bolt
8	2.1019.026.1	14	special nut m 12 p.1.5
9	0.029.1117.0	10	stud bolt
10	2.1599.144.0	14	shoulder
11	0.037.1155.0	1	bushing
12	2.1559.111.0	2	bushing 12x14x10
13	0.029.1154.0	4	gasket
14	2.1699.114.0	1	pin 8x55
15	2.1653.711.0	1	pin
16	2.0432.025.1	2	stud bolt m 8 p 1.25-1x100
17	0.044.1159.0	1	flange
18	2.1653.708.0	2	pin 8x18
19	2.1652.911.0	2	cylindrical plug 12x25
20	2.0432.153.2	2	stud bolt
21	2.0112.513.2	11	screw m 14 p.2 x 35
22	2.0432.255.2	2	stud bolt m 12 p.1.75-1.25x25
23	2.3170.022.1	1	expansion plug 60
24	2.3130.003.1	2	plug 3/8" gas
25	2.3130.002.1	1	plug 1/4" gas
26	0.044.1120.0/10	6	engine cylinder
27	2.1589.052.0	12	shoulder ring 115x123x0.2
28	2.1589.051.0	6	shoulder ring 116x123x0.1
29	2.1569.076.0	6	gasket 116x123x0.5
30	0.039.1122.0	24	stud bolt m 12 p.1.5x310
31	0.041.1123.0	6	stud bolt m 10
32	0.044.1156.0	12	special bushing
33	0.041.1151.3/10	6	sprayer nozzle
34	2.3130.001.1	5	plug 1/8" gas
35	2.1653.306.0	2	pin
36	2.3139.001.0	6	plug m 12 p.1.75
37	2.0432.003.2	8	stud bolt m 8 p.1x20
38	0.044.1151.0	2	gasket
39	0.044.1150.0	2	cover
40	2.1310.004.2	8	flat washer 8.4x17

## Section: ENGINE

**CRANKCASE**

Fig.	P/n	QTY	Name
41	2.0112.204.2	8	screw m 8 p.1.25x14
42	0.044.1155.2/20	1	cover
43	0.045.1150.0	1	oil seal
44	0.044.1152.0	1	tube
45	2.1480.014.1	1	washer 8
46	2.0312.206.2	1	screw m 8 p 1.25 x 20
47	0.044.1153.0/10	1	gasket
48	0.044.1154.0	1	cover
49	2.1480.014.1	4	washer 8
50	2.0112.209.2	4	screw m 8 p 1.25 x 25
51	2.1011.207.2	2	nut m 12 p.1.5

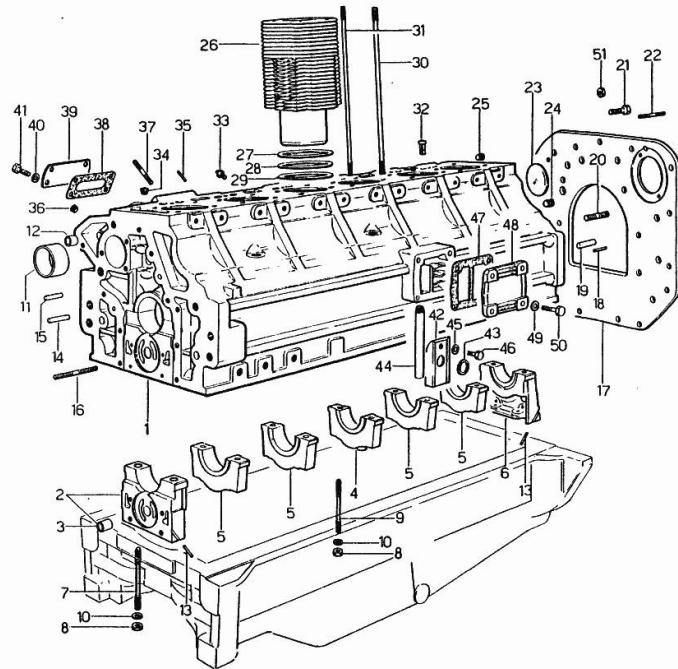

## Section: ENGINE

## TIMING CASE

Fig.	P/n	QTY	Name
------	-----	-----	------

## Notes:

[R 1156]

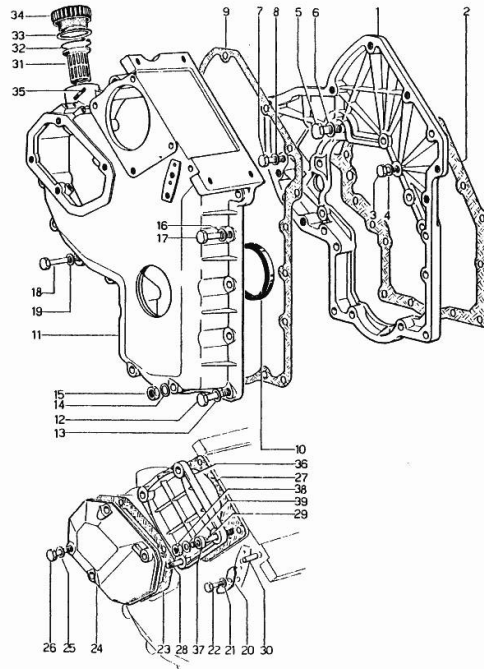

1	0.048.1131.0	1	flange
2	0.041.1153.0	1	gasket
3	2.0112.209.2	5	screw m 8 p 1.25 x 25
4	2.1480.014.1	5	washer 8
5	2.0119.034.1	1	screw m 14 p.2x20
6	2.1560.010.0	1	gasket 14.2 x 20
7	2.0112.207.2	1	screw m 8 p 1.25 x 20
8	2.1480.014.1	1	washer 8
9	0.041.1152.0	1	gasket
10	2.1519.010.0	1	special oil seal 58x80x10
11	0.048.1132.0	1	guard
12	2.0112.217.2	5	screw m 8 p.1.25 x 45
13	2.1480.014.1	5	washer 8
14	2.1560.003.0	2	copper gasket 8.2 x 12
15	2.1011.405.2	2	nut m 8 p.1
16	2.1480.014.1	2	washer 8
17	2.0112.211.2	2	screw m 8 p.1.25 x 30
18	2.0112.222.2	4	screw m 8 p.1.25x65
19	2.1480.014.1	4	washer 8
20	0.041.1158.0	1	index
21	2.1310.004.2	1	flat washer 8.4x17
22	2.0112.204.2	1	screw m 8 p.1.25x14
23	0.048.1152.0	1	gasket
24	0.048.1150.0/20	1	cover
25	2.1560.005.0	4	copper gasket 10.2 x 14
26	2.0112.315.2	4	screw m 10 p.1.5 x 40
27	0.041.1154.0	1	gasket
28	2.0432.015.2	1	stud bolt m 8 p.1.25-1x50
29	2.0432.028.1	3	stud bolt m 8 p.1.25-1x130
30	2.1653.717.0	1	pin 8 x 40
31	0.041.1159.0/10	1	filter
32	2.1411.012.1	1	circlip 30
33	2.1569.072.0	1	gasket 32 x 39.5 x 2
34	0.041.1135.0	1	plug
35	2.0119.081.2	2	screw
36	0.037.1151.0	1	cover
37	2.1579.191.0	4	spacer 8.5 x 18 x 20
38	2.1011.505.2	4	nut m 8 p.1
39	2.1310.004.2	4	flat washer 8.4x17

## Section: ENGINE

**CRANKSHAFT**

Fig.	P/n	QTY	Name
------	-----	-----	------

**Notes:**

[R 1156]

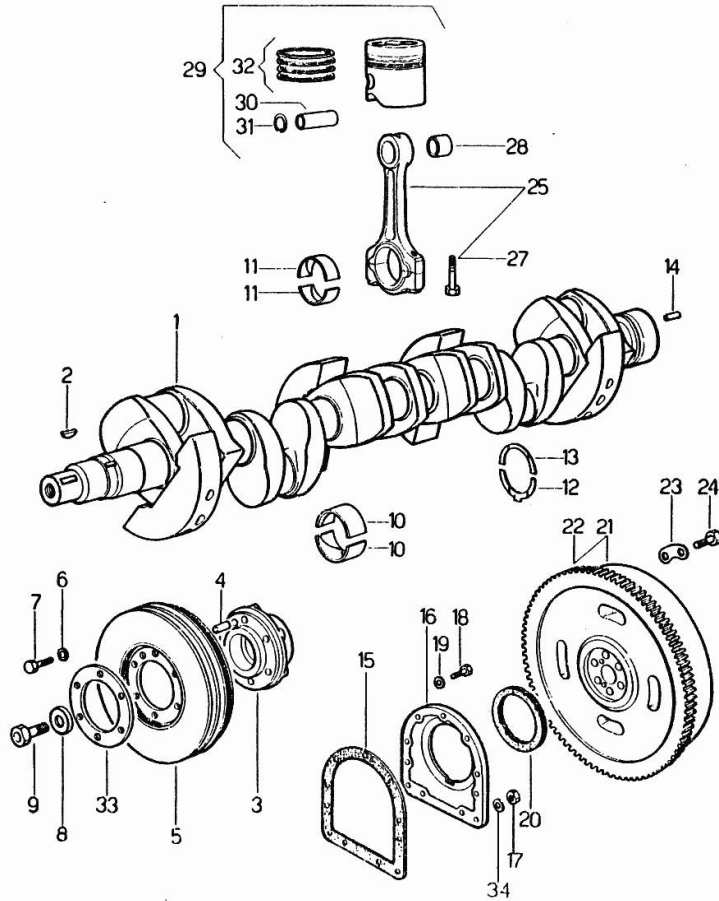

1	0.037.1210.4/20	1	crankshaft
2	2.1799.002.0	1	stick 10x13
3	0.037.1250.0/10	1	hub
4	2.1651.909.0	1	cylindrical plug 12 x 20
5	0.046.1246.3	1	antivibration pulley
6	2.1470.007.2	6	lock washer 12
7	2.0122.461.2	6	screw m 12 p.1.25x30
8	0.001.6020.0	1	shoulder
9	2.0129.032.2	1	screw m 24 p.2x45
10	0.029.0066.0		main half bushing - mm 1.00
10	0.029.1215.0/10	14	main half bushing
10	0.029.1215.7		main half bushing - mm 0.25
10	0.029.1215.8		main half bushing - mm 0.50
10	0.029.1215.9		main half bushing - mm 0.75
11	0.039.1225.0	12	con.rod half bushing
11	0.039.1225.7		con.rod half bushing -mm 0.254
11	0.039.1225.8		con.rod half bushing -mm 0.508
11	0.039.1225.9		con.rod half bushing -mm 0.762
12	0.001.4547.0		shoulder ring + mm 0.05
12	0.001.4548.0		shoulder ring + mm 0.10
12	0.001.4549.0		shoulder ring + mm 0.15
12	0.042.1219.0	2	shoulder ring STANDARD
13	0.001.4544.0		shoulder ring + mm 0.05
13	0.001.4545.0		shoulder ring + mm 0.10
13	0.001.4546.0		shoulder ring + mm 0.15
13	0.042.1218.0	2	shoulder ring STANDARD
14	2.1652.915.0	2	cylindrical plug 12x35
15	0.029.1250.0	1	gasket
16	0.029.1240.0	1	flange
17	2.1011.421.2	2	nut m 10 p.1.25
18	2.0112.309.2	7	screw m 10 p.1.5 x 25
19	2.1480.015.1	7	washer 10
20	2.1519.009.0	1	special oil seal
21	0.046.1253.3/10	1	flywheel
22	0.036.1242.0	1	crown wheel Z = 126, mm 15
23	2.1379.006.0	3	lock-tab 15x15x36,5
24	2.0122.515.2	6	screw m 14 p.1.5x40
25	0.052.1220.3	6	engine connecting rod
27	0.039.1250.0	12	screw m 14 p.1.5x63
28	0.002.4168.0	6	bearing
29	0.046.0060.6	6	complete piston

Section: ENGINE  
CRANKSHAFT

Fig.	P/n	QTY	Name
29	0.046.0061.6	6	complete piston + mm 0.5
29	0.046.0062.6	6	complete piston + mm 1.0
30	0.002.4167.0	6	piston pin
31	2.1411.014.1	12	circlip 35
32	0.045.0052.6	6	piston ring set
32	0.045.0053.6	6	piston ring set + mm 0.5
32	0.045.0054.6	6	piston ring set + mm 1.00
33	0.037.1255.0	1	flange
34	2.1560.006.0	2	gasket 10.2 x 16

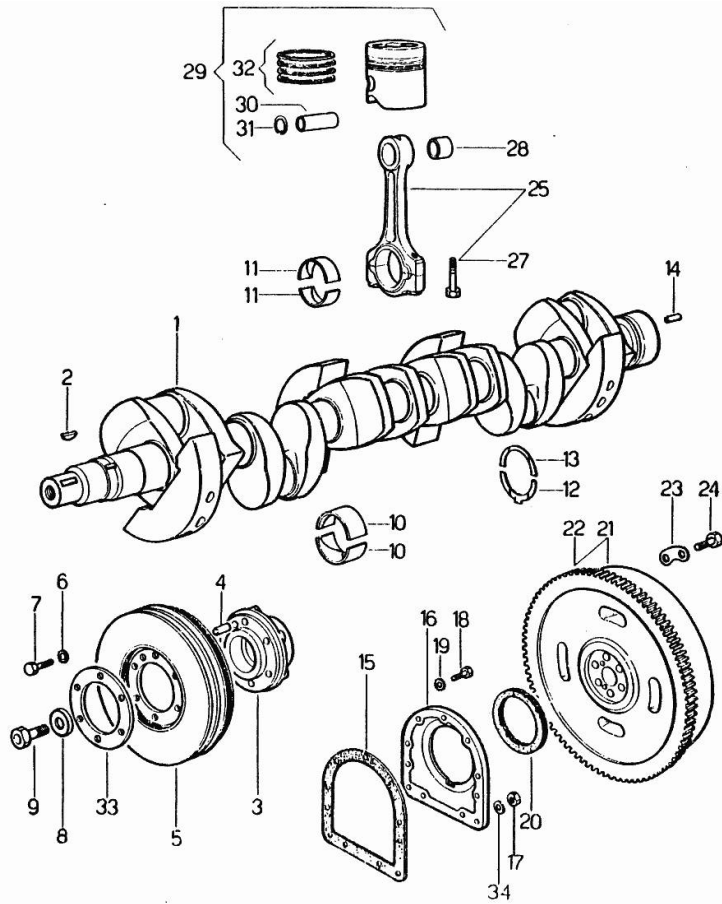

Section: ENGINE

**CAMSHAFT**

Fig.	P/n	QTY	Name
------	-----	-----	------

**Notes:**

[R 1156]

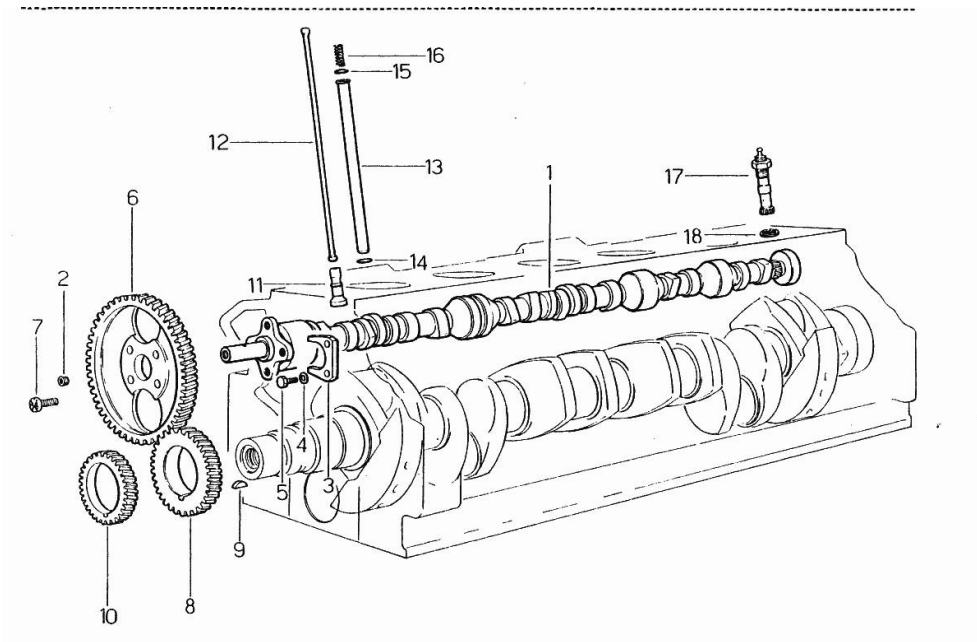

1	0.047.1310.0	1	camshaft
2	2.3120.001.4	1	plug m 18 p.1.5
3	0.027.1314.0	1	flange
4	2.1470.004.2	2	lock washer 8
5	2.0312.206.2	2	screw m 8 p 1.25 x 20
6	0.041.1321.0	1	gear z = 66
7	2.0139.005.1	4	screw m 10 p.1 x 25
8	0.040.1320.0	1	gear z = 33
9	2.1720.010.0	1	key 5x9
10	0.040.1323.0/10	1	gear Z = 38
11	0.044.1330.0/10	12	tappets
12	0.041.1331.3	12	rod
13	0.041.1332.0	12	sleeve
14	2.1539.020.0	12	special oil seal 13.95x2.62
15	2.1539.022.0	12	special oil seal 12.37x2.62
16	2.4019.162.1/20	12	spring 17.2x46x1.8
17	0.041.1355.3	1	transmission
18	2.1560.013.0	1	gasket 18.2x22

Section: ENGINE  
CYLINDER HEAD

Fig.	P/n	QTY	Name
------	-----	-----	------

## Notes:

[R 1156]

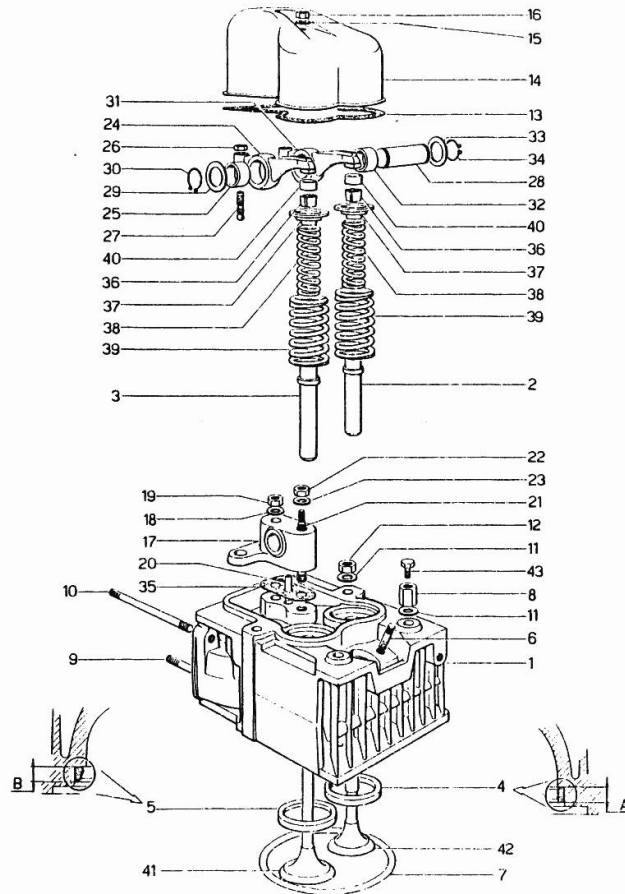

0	0.042.0057.6	1	gasket set
1	0.044.1450.3/20	6	engine head
2	0.037.1417.0/10	6	valve guide
3	0.037.1416.0	6	valve guide
4	0.037.1452.0	6	valve seat
5	0.037.1451.0	6	valve seat
6	2.0439.087.1	10	stud bolt
7	2.1569.078.0	6	gasket 106x118x0.5
8	2.1019.037.1	6	nut m 12 p.1.5x35
9	2.0432.007.1	10	stud bolt m 8 p.1.25 / p.1 x 30
10	2.0432.026.1	6	stud bolt m 8 p.1.25 - 1.00 x 110
11	2.1599.144.0	20	shoulder
12	2.1019.025.1	18	special nut
13	0.029.1450.0	6	gasket
14	0.039.1440.2	6	cap
15	2.1560.004.0	6	copper gasket 8.2 x 14
16	2.1099.056.1	6	special nut m8 p.1
17	0.041.1430.0	6	support
18	2.1599.160.0	6	washer 10.5x19x4
19	2.1099.035.1	6	special nut
20	0.029.1452.0	6	tube
21	0.039.1451.0	6	stud bolt
22	2.1011.421.2	6	nut m 10 p.1.25
23	2.1310.006.2	6	flat washer 10.5x21
24	002.5937.3/30	6	rocker arm
25	2.1559.021.0/40	6	bushing 15x19x22
26	2.1011.405.2	10	nut m 8 p.1
27	0.021.1434.0	10	screw
28	0.041.1431.0	6	pin
29	2.1599.019.0	6	shoulder ring 19.5x31x2
30	2.1410.055.1	6	circlip 19
31	0.002.5936.3/40	6	rocker arm
32	2.1559.021.0/40	6	bushing 15x19x22
33	2.1599.019.0	6	shoulder ring 19.5x31x2
34	2.1410.055.1	6	circlip 19
35	0.034.1450.0	6	tappet gasket
36	0.002.9193.0	12	conical valve cotter
37	0.002.9215.0	12	cup
38	2.4019.194.0	12	spring 22.70x50.7x2.1
39	2.4019.193.0	12	spring 36.15x55.2x3.2
40	0.021.1453.0/20	12	small cover

**Buy Now**



Our support email:

[ebooklibonline@outlook.com](mailto:ebooklibonline@outlook.com)