

Section: ENGINE

CRANKCASE

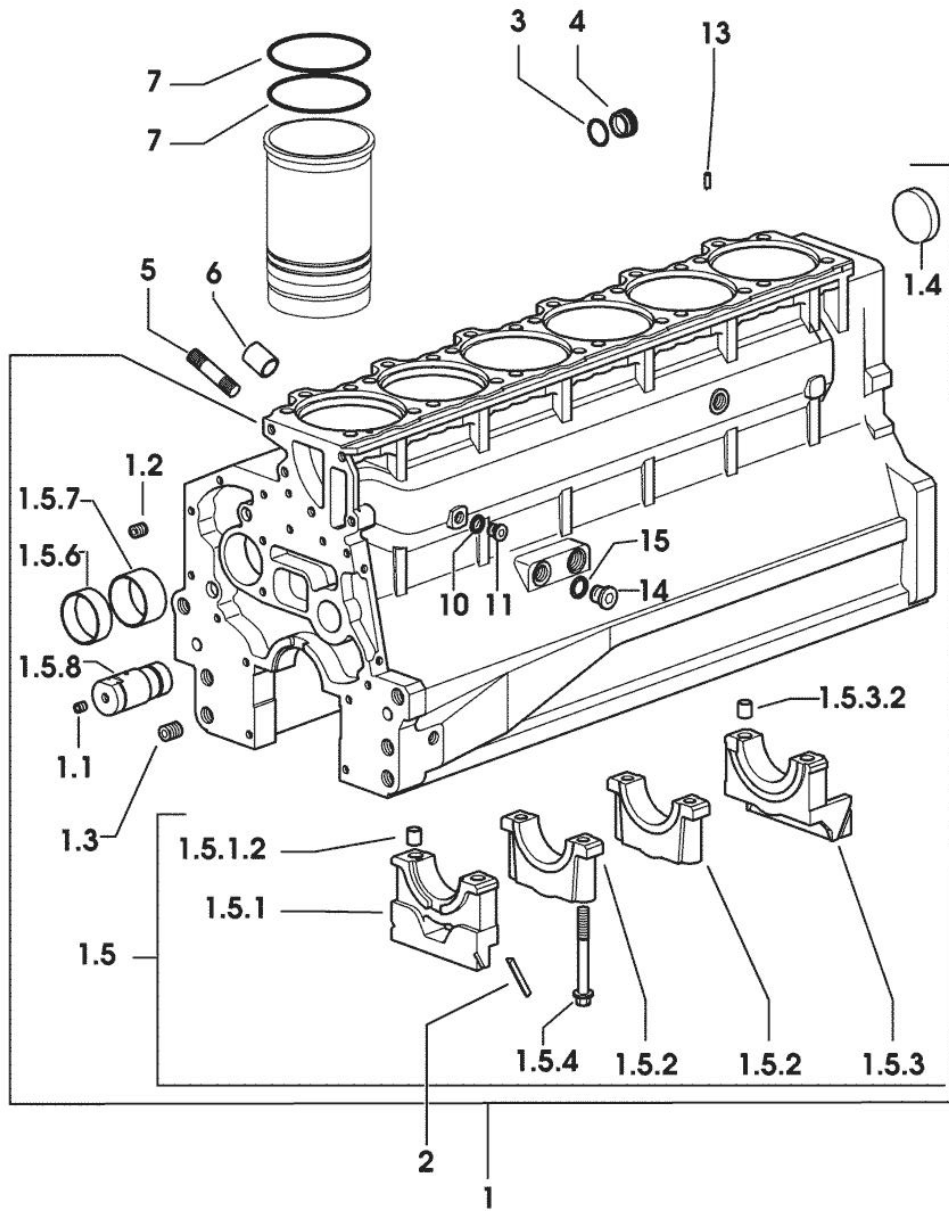

| Fig. | P/n | QTY | Name |
|------|-----|-----|------|
|------|-----|-----|------|

Notes:
[R 1506]

| | | | |
|---------|-----------------|----|---------------------------------|
| 1 | 0.007.1102.6/20 | 1 | crankcase |
| 1.1 | 2.3130.001.1 | 14 | plug 1/8" gas |
| 1.2 | 2.3130.002.1 | 2 | plug 1/4" gas |
| 1.3 | 2.3130.003.1 | 8 | plug 3/8" gas |
| 1.4 | 2.3179.012.0 | 1 | plug 60 |
| 1.5 | 0.000.0000.1 | | cannot be supplied |
| 1.5.1 | 0.065.1112.7 | 1 | support |
| 1.5.1.2 | 2.1699.165.0 | 1 | bush 12.3x15x16 |
| 1.5.2 | 0.065.1114.0/10 | 5 | support |
| 1.5.3 | 0.007.0848.3/10 | 1 | support |
| 1.5.3.2 | 2.1699.165.0 | 1 | bush 12.3x15x16 |
| 1.5.4 | 0.065.1117.0 | 14 | screw m 12 x 100 |
| 1.5.6 | 0.065.1140.0 | 6 | special bushing 59X55X20 |
| 1.5.7 | 0.065.1141.0 | 1 | special bushing 59X55X30 |
| 1.5.8 | 0.066.1151.0 | 1 | pin |
| 2 | 0.066.1152.0/10 | 4 | gasket |
| 3 | 2.1532.072.0 | 1 | oil seal 26.70x1.78 |
| 4 | 2.3199.405.2 | 1 | plug m 28 p.1.5 |
| 5 | 2.0432.003.7 | 18 | stud bolt m 8 p.1.25 / p.1 x 20 |
| 6 | 2.1559.188.2 | 6 | bush 11.4 x 14 x16 |
| 7 | 2.1539.193.0 | 12 | special oil seal 107.62x2.62 |
| 10 | 2.1560.010.0 | 1 | gasket 14.2 x 20 |
| 11 | 2.3199.292.0 | 1 | plug 1/4" gas |
| 13 | 2.1549.154.2 | 6 | bush 4.8x5.8x16 |
| 14 | 2.3120.101.0 | 1 | plug m 18 p.1.5 |
| 15 | 2.1560.014.0 | 1 | washer 18.2 x 24 |

9_01311_00_0_0

Section: ENGINE

MONOBLOC ENGINE-GEARBOX CONNECTING FLANGE

9_N0411_01_0_0

| Fig. | P/n | QTY | Name |
|------|-----|-----|------|
|------|-----|-----|------|

Notes:

[R 1506]

| | | | |
|----|-----------------|----|-----------------------------------|
| 1 | 2.3131.003.2 | 1 | plug m 16 p.1.5 |
| 2 | 2.0112.534.2 | 2 | screw m 14 p.2x125 |
| 3 | 2.1310.009.2 | 2 | flat washer 15x20 |
| 6 | 2.0439.250.7 | 1 | stud bolt m 12 / m 10 x 30 |
| 7 | 0.011.9294.0/10 | 1 | bush |
| 8 | 0.007.0809.0/20 | 1 | flange |
| 9 | 2.0112.513.2 | 11 | screw m 14 p.2 x 35 |
| 10 | 2.0432.328.7 | 4 | stud bolt m 14 p.2-1.5x130 |
| 12 | 2.0112.531.2 | 2 | screw m 14 p.2x110 |
| 13 | 2.1651.911.0 | 2 | cylindrical plug |
| 14 | 2.1011.108.2 | 6 | nut m 14 p.2 |
| 15 | 2.0432.257.7 | 1 | stud bolt m 12 p.1.75 - 1.25 x 30 |
| 16 | 2.0312.520.2 | 2 | screw m 14 p.2x70 |

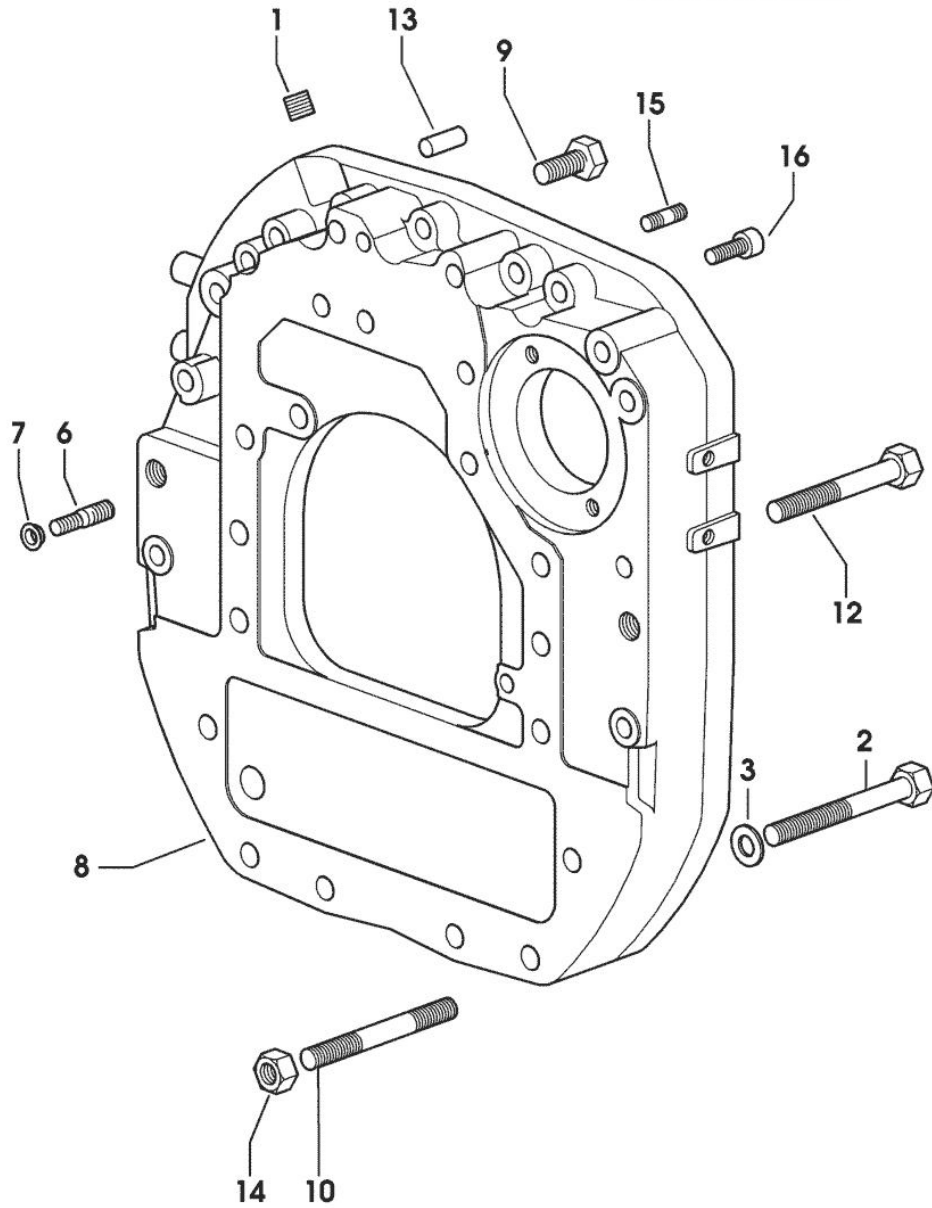

9_33611_01_0_0

Section: ENGINE

TIMING CASE

| Fig. | P/n | QTY | Name |
|------|-----|-----|------|
|------|-----|-----|------|

Notes:

[R 1506]

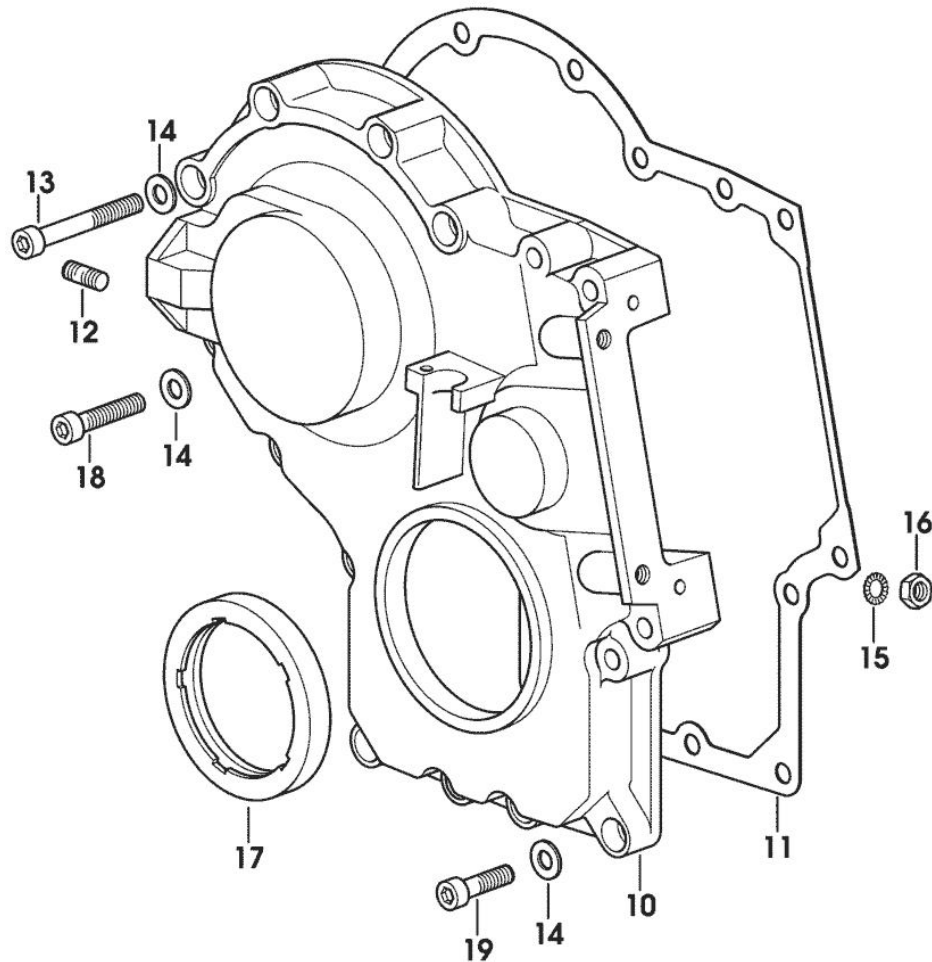

| | | | |
|----|-----------------|----|---------------------------------|
| 10 | 0.013.4981.0 | 1 | guard |
| 11 | 0.065.1150.0/30 | 1 | gasket |
| 12 | 2.0432.003.7 | 2 | stud bolt m 8 p.1.25 / p.1 x 20 |
| 13 | 2.0312.219.2 | 4 | screw m 8 p.1.25x65 |
| 14 | 2.1480.014.1 | 15 | washer 8 |
| 15 | 2.1470.004.2 | 4 | lock washer 8 |
| 16 | 2.1011.405.2 | 2 | nut m 8 p.1 |
| 17 | 2.1529.141.0 | 1 | special oil seal |
| 18 | 2.0312.214.2 | 3 | screw m 8 p.1.25 x 40 |
| 19 | 2.0312.208.2 | 8 | screw m 8 p.1.25 x 25 |

Section: ENGINE
CASING COVER

| Fig. | P/n | QTY | Name |
|------|-----|-----|------|
|------|-----|-----|------|

Notes:
[R 1506]

| | | | |
|----|--------------|---|--------------------------------|
| 30 | 0.065.1152.0 | 1 | gasket |
| 31 | 0.065.1151.0 | 1 | cover |
| 32 | 2.0112.205.2 | 2 | screw m 8 p.1.25 x 16 |
| 34 | 2.0432.005.7 | 2 | stud bolt m 8 p.1.5 / p.1 x 25 |

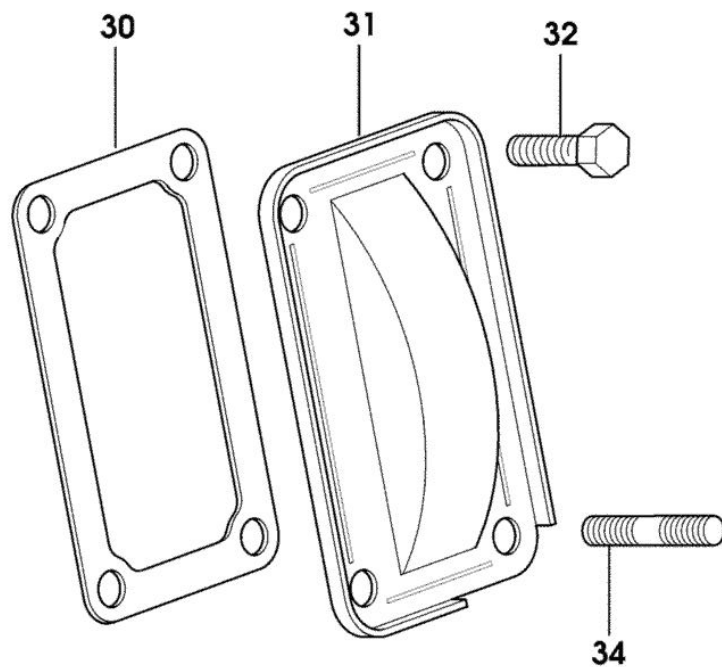

9_33011_04_0_0

Section: ENGINE

GUARD PLATE

| Fig. | P/n | QTY | Name |
|------|-----|-----|------|
|------|-----|-----|------|

Notes:
[R 1506]

| | | | |
|---|-----------------|---|-------------------------------------|
| 1 | 0.007.1262.3/50 | 1 | guard |
| 2 | 0.007.1271.0/10 | 1 | small column m 8 p.1.25 / L = mm 60 |
| 3 | 0.007.1272.0/10 | 2 | small column m 8 p.1.25 / L = mm 50 |
| 5 | 2.1310.004.2 | 3 | flat washer 8.4x17 |
| 7 | 2.0112.203.2 | 3 | screw m 8 p.1.25 x 12 |

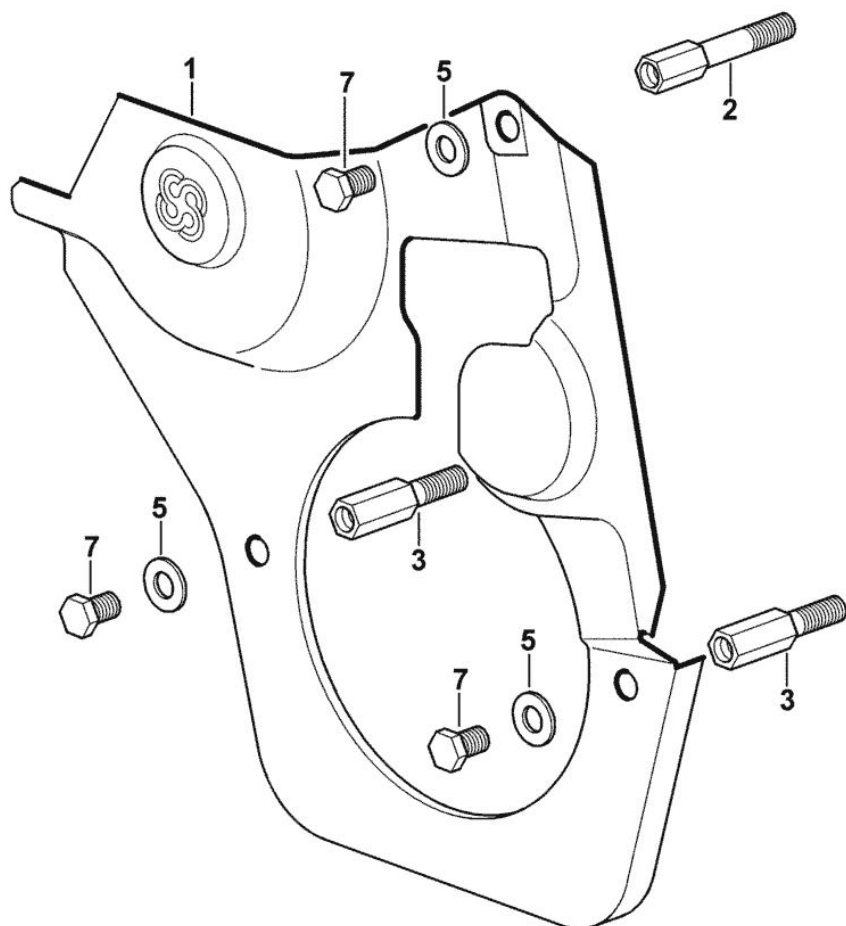

Section: ENGINE
CRANKSHAFT

| Fig. | P/n | QTY | Name |
|------|-----|-----|------|
|------|-----|-----|------|

Notes:
 [R 1506]

| | | | |
|------|-----------------|---|---------------------------------|
| 2 | 2.1651.915.0 | 1 | pin 12x35 |
| 3 | 0.065.1215.0 | 7 | main half bushing STANDARD |
| 3 | 0.065.1215.7 | | main half bushing - mm 0.25 |
| 3 | 0.065.1215.8 | | main half bushing - mm 0.50 |
| 4 | 0.065.1216.0 | 7 | main half bushing |
| 4 | 0.065.1216.7 | | main half bushing - mm 0.25 |
| 4 | 0.065.1216.8 | | main half bushing - mm 0.50 |
| 5 | 0.065.1218.0 | 4 | shim STANDARD |
| 5 | 0.065.1218.7 | | shim + mm 0.10 |
| 5 | 0.065.1218.8 | | shim + mm 0.15 |
| 6 | 2.1599.524.7 | 1 | washer 21x60x12 |
| 7 | 2.1720.006.0 | 1 | key 4x6.5 |
| 9 | 0.065.1254.0/20 | 1 | gasket |
| 10 | 0.007.0851.0/10 | 1 | cover |
| 11 | 2.1529.073.0 | 1 | special oil seal 110x130x13 |
| 12 | 2.1475.002.2 | 9 | conical washer 8 |
| 13 | 2.0112.207.2 | 7 | screw m 8 p 1.25 x 20 |
| 14 | 2.3130.001.1 | 6 | plug 1/8" gas |
| 15 | 2.1589.137.0 | 2 | shoulder ring 71x110x1 |
| 16 | 2.0432.003.7 | 2 | stud bolt m 8 p.1.25 / p.1 x 20 |
| 17 | 2.1011.105.2 | 2 | nut m 8 p.1.25 |
| 20 | 0.009.3704.3 | 1 | antivibration pulley |
| 21 | 0.010.4320.3/20 | 1 | crankshaft |
| 21.2 | 0.007.0855.0/10 | 1 | gear |
| 22 | 0.011.2206.0/10 | 1 | hub |
| 23 | 2.0399.144.7/10 | 1 | screw m 20 p.1.5x51 |

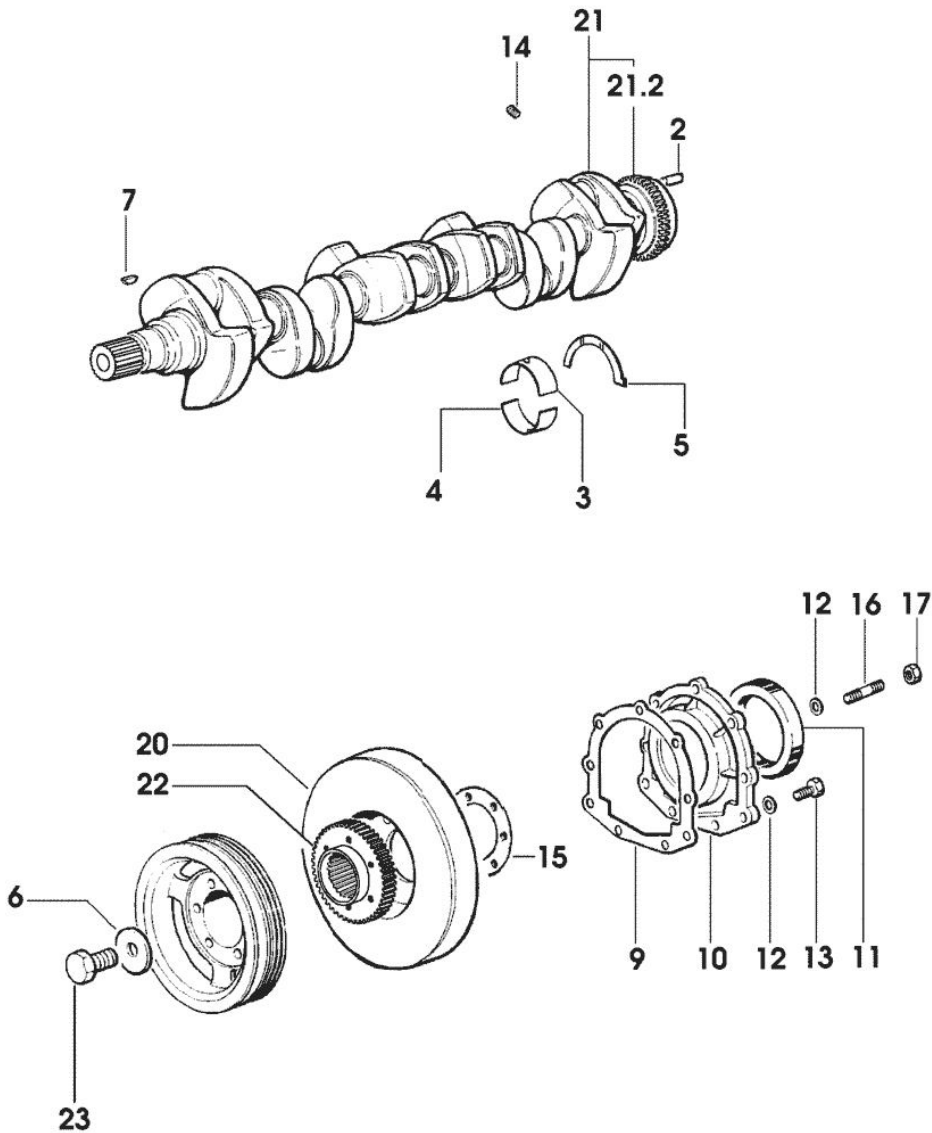

9_37912_00_0_0

Section: ENGINE

CYLINDER - PISTON - CONNECTING ROD

| Fig. | P/n | QTY | Name |
|------|-----|-----|------|
|------|-----|-----|------|

Notes:

[R 1506]

| | | | |
|-------|-----------------|----|--|
| 1 | 0.384.0065.A | 6 | cyl. piston assembly "A" - CLASS A |
| 1 | 0.384.0065.B | 6 | cyl. piston assembly "B" - CLASS B |
| 1.1 | 0.A12.2675.0 | 1 | engine cylinder "A" - CLASS A |
| 1.1 | 0.B12.2675.0 | 1 | engine cylinder "B" - CLASS B |
| 1.2 | 0.383.0060.A | 1 | complete piston "A" - CLASS A |
| 1.2 | 0.383.0060.B | 1 | complete piston "B" - CLASS B |
| 1.2.1 | 0.338.0052.6/20 | 1 | piston ring set |
| 1.2.2 | 2.1411.014.1 | 2 | circlip 35 |
| 1.2.3 | 0.078.1236.0 | 1 | piston pin Ø 18 / Ø 35 / L = mm 86 |
| 2 | 0.065.1225.0 | 12 | con.rod half bushing STANDARD - A = 28.75 -> 29.00 |
| 2 | 0.065.1225.7 | 12 | con.rod half bushing - mm 0.25 |
| 2 | 0.065.1225.8 | 12 | con.rod half bushing - mm 0.50 |
| 3 | 0.078.1220.3/30 | 6 | engine connecting rod |
| 3.1 | 2.0399.213.0 | 2 | screw m 12 p.1.25x61.5 |
| 3.2 | 2.1559.114.0/10 | 1 | special bushing |

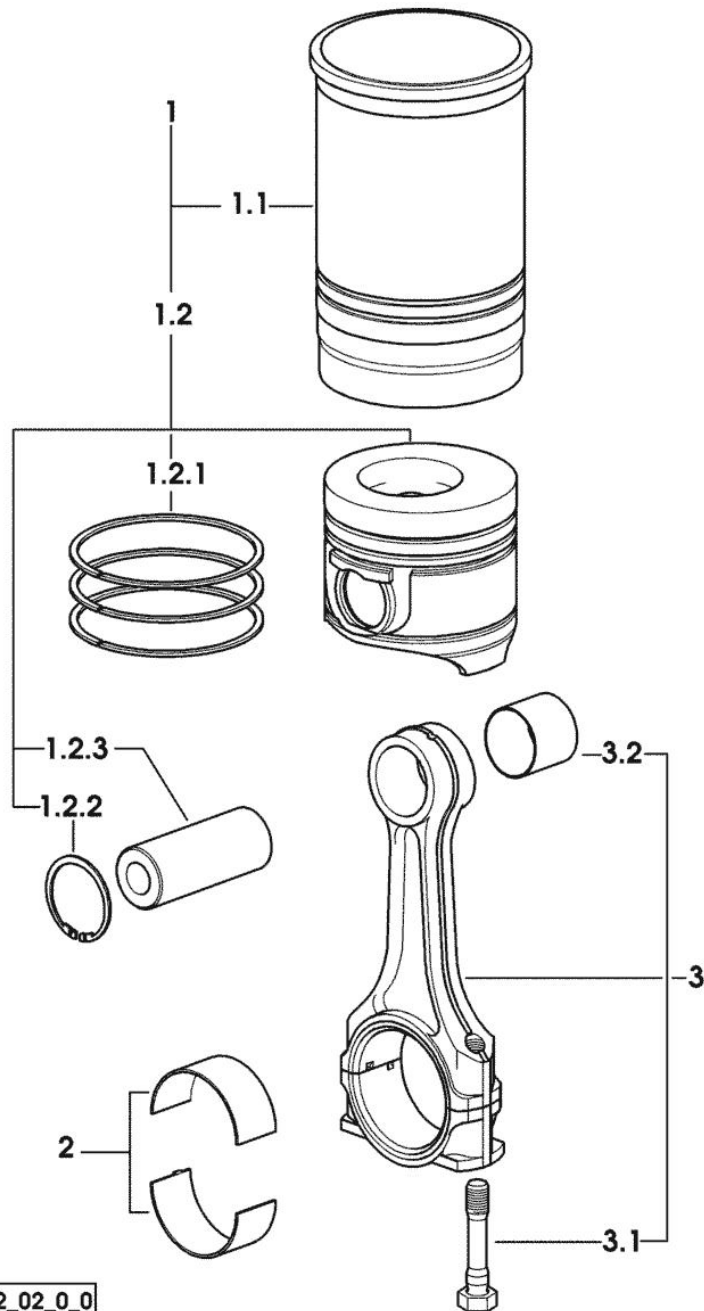

9_38312_02_0_0

Buy Now



Our support email:

ebooklibonline@outlook.com