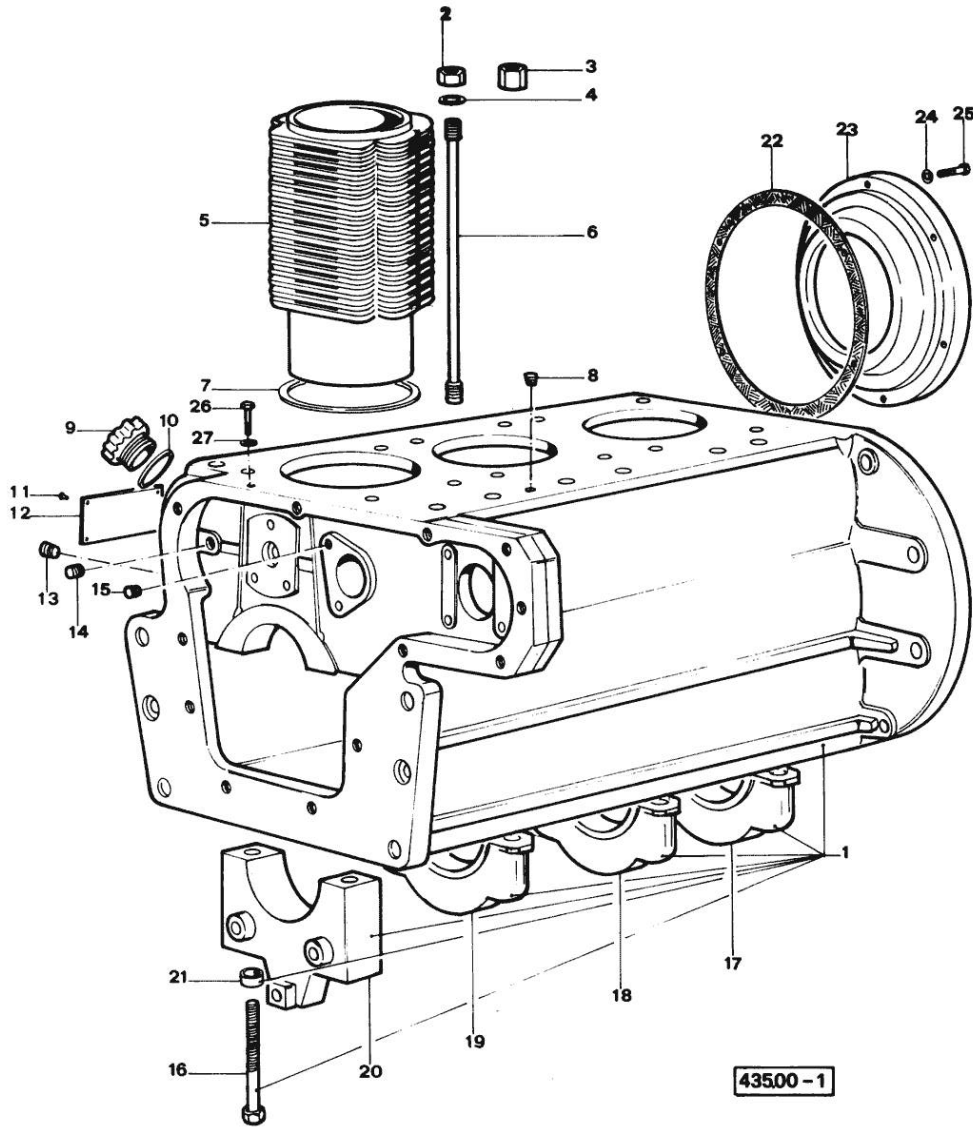

Section: ENGINE
CRANKCASE

Fig.	P/n	QTY	Name
------	-----	-----	------

Notes:
[R 503]

0	0.311.0050.6	1	gasket set
1	0.311.1110.4/10	1	crankcase
2	2.1019.526.1	3	special nut
3	2.1019.527.1	9	special nut
4	2.1311.008.2	10	flat washer 12
5	0.311.1120.0/10	3	engine cylinder
6	0.311.1122.0	12	stud bolt
7	0.311.1156.0	3	ring
8	2.3199.525.0	1	plug
9	0.318.1135.0	1	plug
10	2.1539.513.0	1	special oil seal
11	2.1830.010.0	4	rivet
13	2.3199.526.0	4	plug m 10 p.1x8
14	2.3199.527.0	2	plug
15	2.3199.528.0	1	plug
16	2.0119.536.1	8	screw
17	0.311.1116.9	1	support
18	0.311.1114.9	1	support
19	0.311.1113.9	1	support
20	0.311.1112.9	1	support
21	2.1579.611.0	8	special bushing
22	0.318.1256.0	1	gasket
23	0.311.1133.0	1	cover
24	2.1481.057.1	6	washer 8
25	2.0112.207.2	6	screw m 8 p 1.25 x 20
26	2.0112.204.2	1	screw m 8 p.1.25x14
27	2.1560.004.0	1	copper gasket 8.2 x 14

Section: ENGINE
TIMING CASE

Fig.	P/n	QTY	Name
------	-----	-----	------

Notes:
[R 503]

1	2.0112.023.2	1	screw m 6 p.1x70
2	2.1560.001.0	1	gasket 6.2x10
3	0.311.1155.0	1	cover
4	0.311.1151.0	2	gasket
5	0.311.1132.0/10	1	cover
6	0.311.1154.0	1	body
7	2.6899.504.0	1	clamp
8	0.311.1153.0	1	gasket
9	0.311.1157.0	1	tube
10	0.311.1152.0	1	gasket
11	0.311.1150.0	1	small cover
12	2.0422.218.2	5	stud bolt m 8 x 65
13	2.0422.216.2	5	stud bolt
14	2.1011.005.2	12	nut m 8 p.1.25
15	2.1481.057.1	12	washer 8
16	2.0422.204.2	1	stud bolt
17	2.0422.207.2	2	stud bolt m 8 p 1.25 x 30

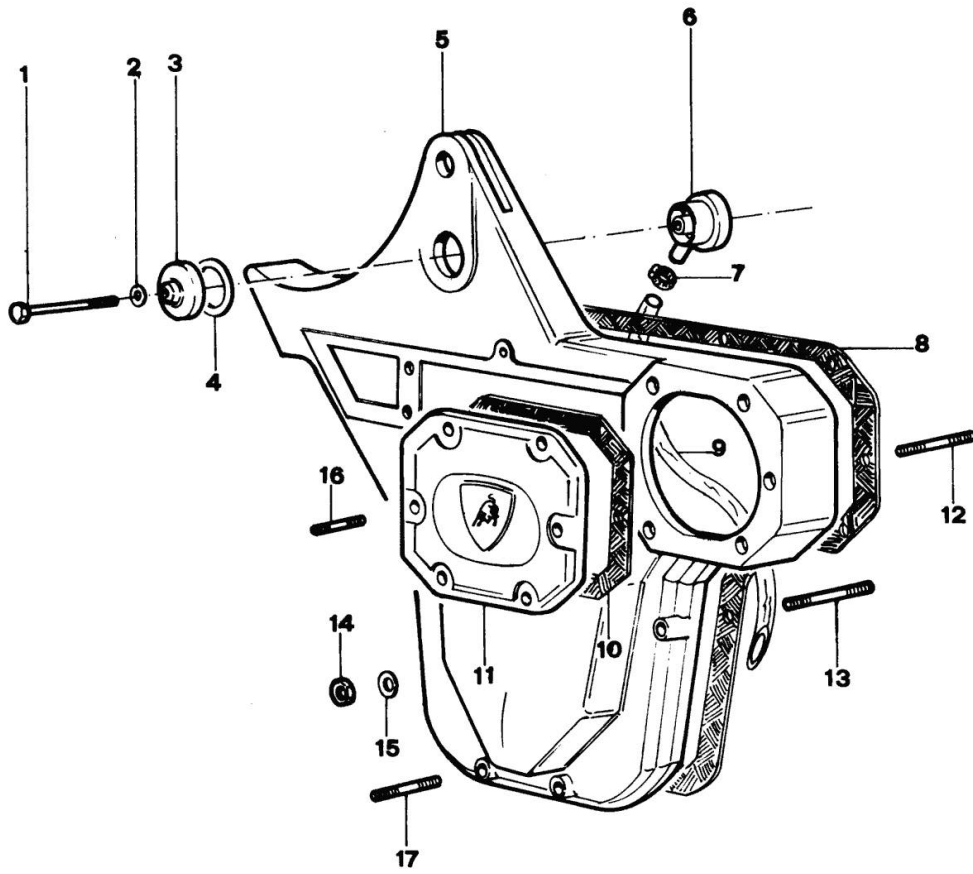

43500 - 2

Section: ENGINE
CRANKSHAFT

Fig.	P/n	QTY	Name
------	-----	-----	------

Notes:
[R 503]

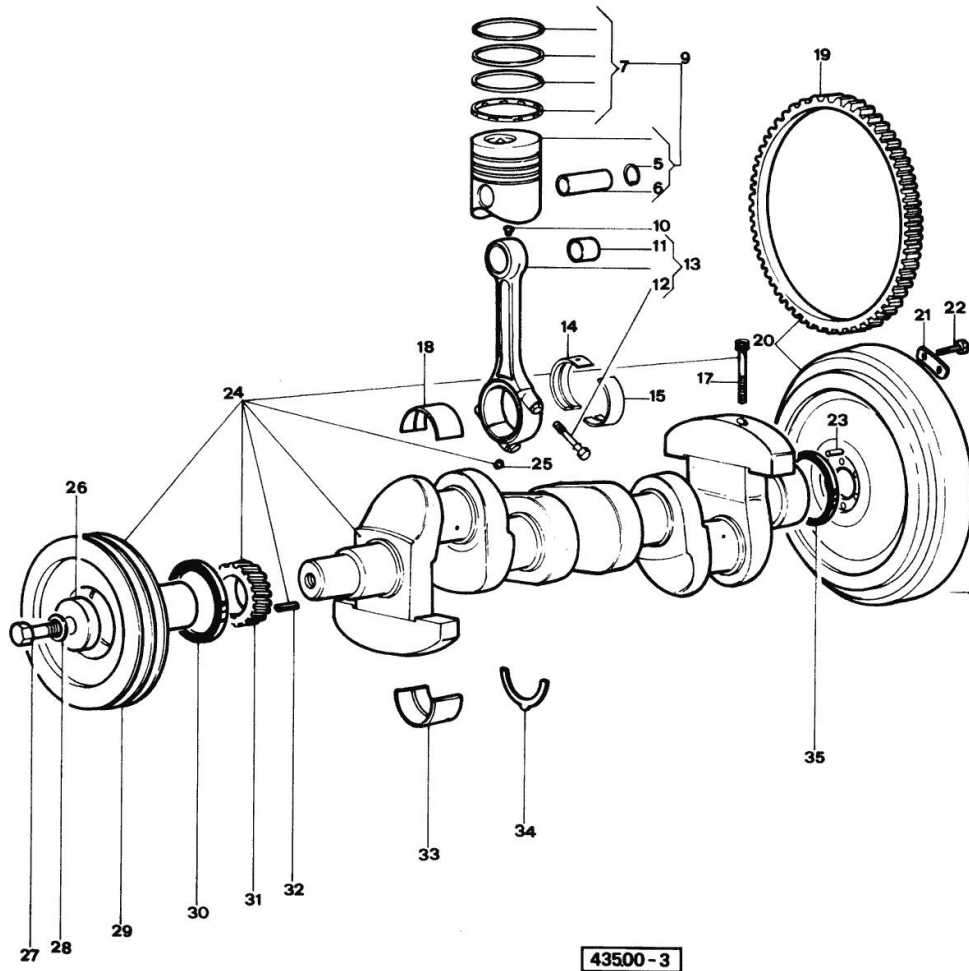

5	2.1411.014.1	6	circlip 35
6	0.311.1236.0	3	piston pin
7	0.311.0052.4	3	piston ring set STANDARD
7	0.311.0053.4	3	piston ring set + mm 0.40
7	0.311.0054.4	3	piston ring set + mm 0.80
9	0.311.0060.6/10	3	complete piston STANDARD
9	0.311.0061.6/10	3	complete piston + mm 0.40
9	0.311.0062.6/10	3	complete piston + mm 0.80
10	0.311.1256.0	3	screw
11	0.311.1227.0/20	6	special bushing
12	2.0399.536.1	1	screw
13	0.311.1220.3/10	3	engine connecting rod
14	0.311.0068.0	3	con.rod half bushing 65358 <=
14	0.311.0068.0/10	3	con.rod half bushing + mm 1.016 => 65359
14	0.311.1225.0	3	con.rod half bushing 65359 <=
14	0.311.1225.0/10	3	con.rod half bushing STANDARD => 65359
14	0.311.1225.7	3	con.rod half bushing 65358 <=
14	0.311.1225.7/10	3	con.rod half bushing - mm 0.25 => 65359
14	0.311.1225.8	3	con.rod half bushing 65358 <=
14	0.311.1225.8/10	3	con.rod half bushing - mm 0.50 => 65359
14	0.311.1225.9	3	con.rod half bushing 65358 <=
14	0.311.1225.9/10	3	con.rod half bushing - mm 0.75 => 65359
15	0.311.0069.0/10	3	con.rod half bushing + mm 1.016
15	0.311.1251.0/10	3	con.rod half bushing STANDARD
15	0.311.1251.7/10	3	con.rod half bushing - mm 0.25
15	0.311.1251.8/10	3	con.rod half bushing - mm 0.50
15	0.311.1251.9/10	3	con.rod half bushing + mm 0.762
17	2.0312.517.1	4	screw
18	0.311.0066.0/10	4	main half bushing - mm 1.016
18	0.311.1250.0/10	4	main half bushing STANDARD
18	0.311.1250.7/10	4	main half bushing - mm 0.25

Section: ENGINE
CRANKSHAFT

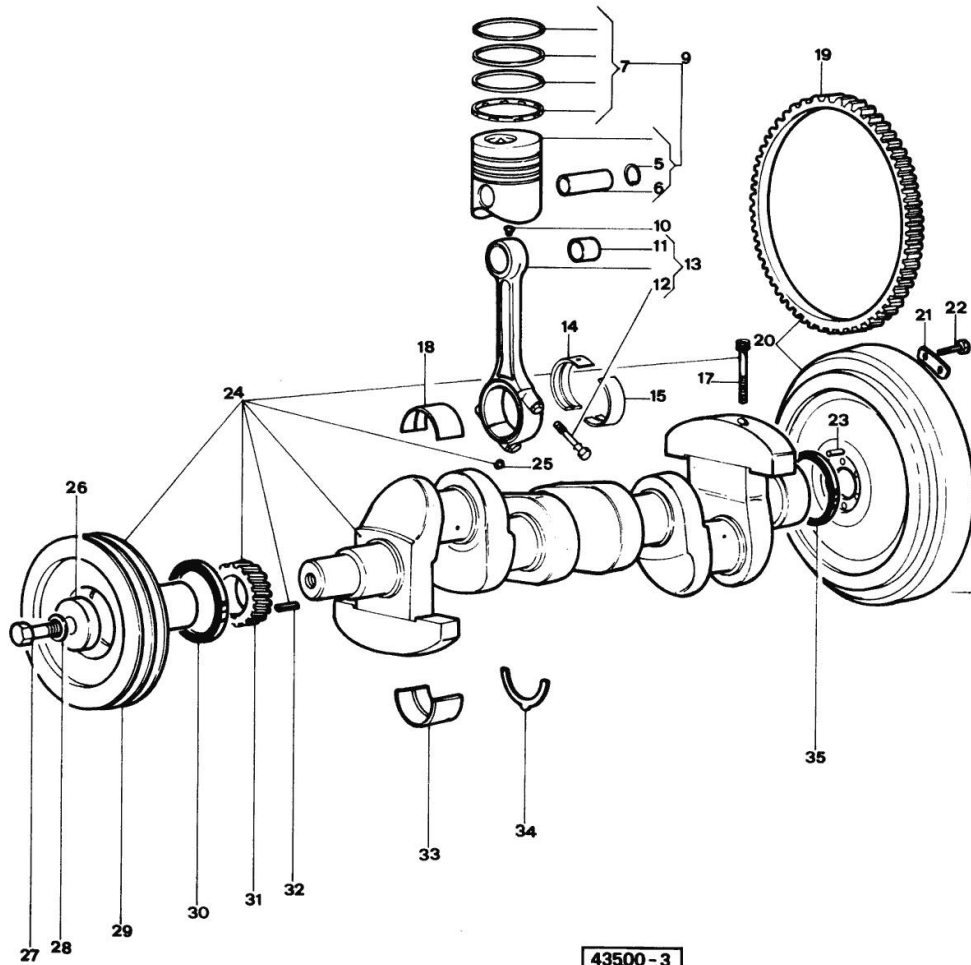

43500 - 3

Fig.	P/n	QTY	Name
18	0.311.1250.8/10	4	main half bushing - mm 0.50
18	0.311.1250.9/10	4	main half bushing -mm 0.762
19	0.311.1242.0	1	crown wheel
20	0.311.1241.3	1	flywheel
			65358 <=
20	0.311.1241.3/10	1	flywheel
			=> 65359
21	0.318.1250.0	2	small plate
22	2.0122.517.7	4	screw m 14 p.1.5x45
23	2.1650.917.0	1	pin
24	0.311.1210.3	1	crankshaft
25	2.3199.523.0	3	plug
26	2.1579.609.0	1	spacer
27	2.0129.510.1	1	screw
28	2.1470.010.2	1	lock washer 18
29	0.311.1244.0	1	pulley
30	2.1529.511.0	1	special oil seal
31	0.311.1320.0	1	gear
32	2.1710.511.0	1	stick
33	0.311.0067.0/10	4	main half bushing - mm 1.016
33	0.311.1215.0/10	4	main half bushing STANDARD
33	0.311.1215.7/10	4	main half bushing - mm 0.25
33	0.311.1215.8/10	4	main half bushing - mm 0.50
33	0.311.1215.9/10	4	main half bushing -mm 0.762
34	0.311.1219.0/10	3	shoulder ring STANDARD
34	0.311.1219.7/10	3	shoulder ring + mm 0.0635
34	0.311.1219.8/10	3	shoulder ring + mm 0.127
34	0.311.1219.9/10	3	shim + mm 0.190
35	2.1529.510.0	1	special oil seal

Section: ENGINE

CAMSHAFT

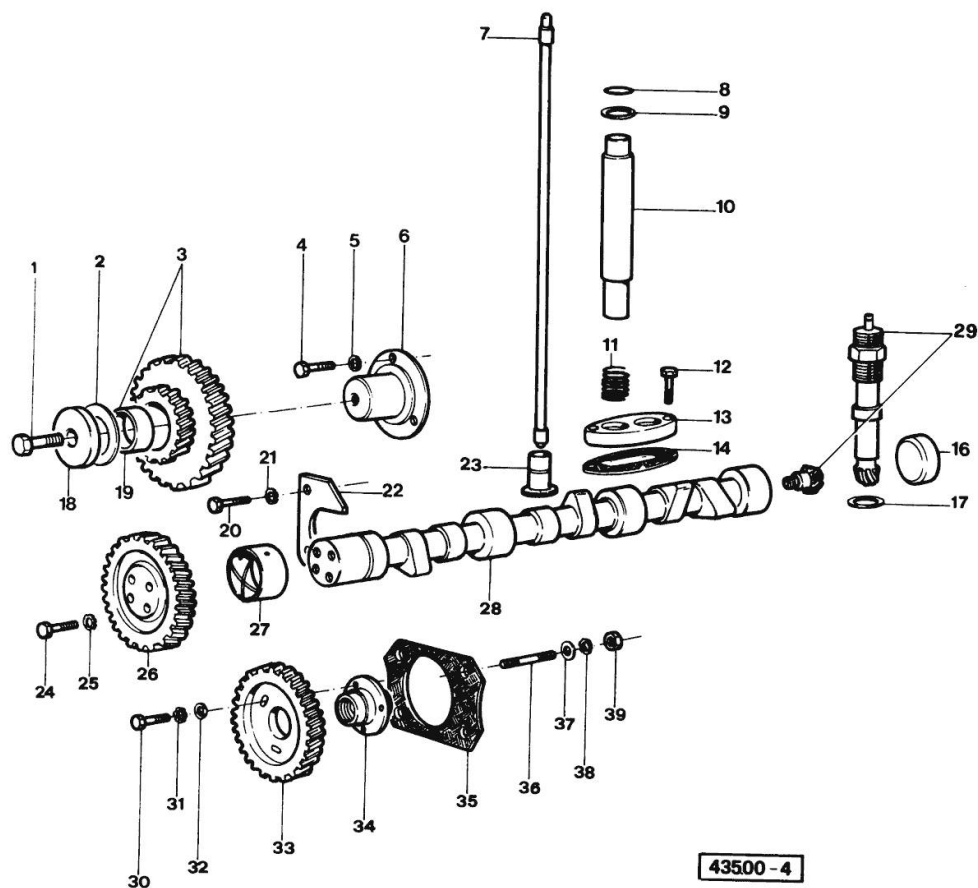

Fig.	P/n	QTY	Name
Notes:			
[R 503]			
1	2.0129.509.1	1	screw
2	0.311.1352.0	2	shim
3	0.311.1356.3	1	gear
4	2.0112.207.2	3	screw m 8 p 1.25 x 20
5	2.1481.057.1	3	washer 8
6	0.311.1351.0	1	pin
7	0.311.1331.3	6	rod
8	2.1539.515.0	12	special oil seal
9	2.1579.604.0	12	washer
10	0.311.1332.0	6	governor housing
11	2.4019.535.1	6	spring
12	2.0112.209.2	6	screw m 8 p 1.25 x 25
13	0.311.1333.0	3	small cover
14	0.311.1354.0	3	gasket
16	2.3199.524.0	1	plug
17	2.1560.014.0	1	washer 18.2 x 24
18	2.1579.610.0	1	washer
19	2.1552.217.0	1	bushing
20	2.0112.207.2	2	screw m 8 p 1.25 x 20
21	2.1481.057.1	2	washer 8
22	0.311.1314.0	1	plate
23	0.318.1330.0	6	tappets
24	2.0119.542.2	4	screw
25	2.1481.057.1	4	washer 8
26	0.782.0252.0/20	1	gear
27	0.311.1355.0	1	special bushing
28	0.311.1310.0	1	camshaft
29	0.311.1350.6	1	transmission
29	0.311.1350.6/10	1	transmission 6032 <- > 6033
30	2.0119.523.2	3	screw
31	2.1481.057.1	3	washer 8
32	2.1310.004.2	3	flat washer 8.4x17
33	0.311.1611.0	1	gear
34	0.311.1612.0	1	hub
35	0.318.1651.0	1	gasket
36	2.0422.309.2	4	stud bolt m 10 x 35
37	2.1310.006.2	4	flat washer 10.5x21
38	2.1481.058.1	4	spring washer 10
39	2.1011.006.2	4	nut m 10 p.1.5

Section: ENGINE
CYLINDER HEAD

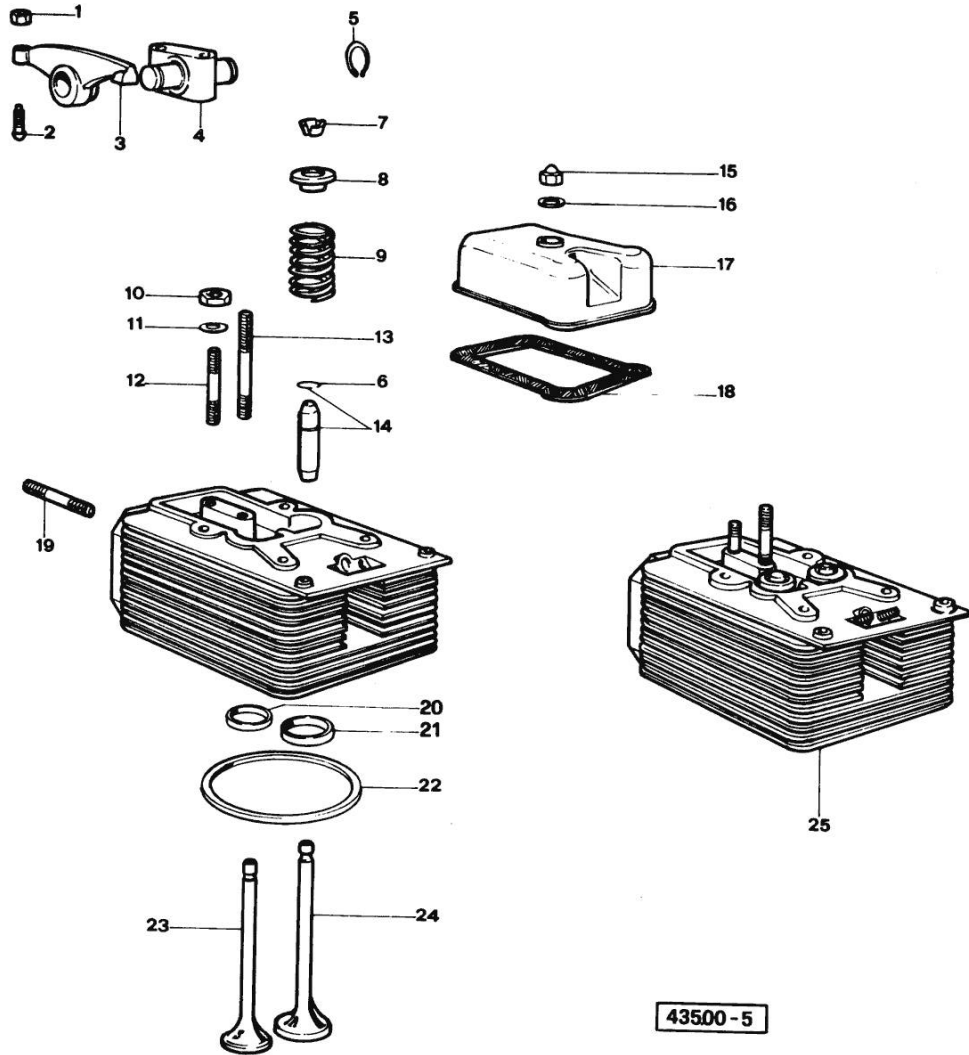

Fig.	P/n	QTY	Name
------	-----	-----	------

Notes:
[R 503]

0	0.311.0058.6	3	gasket set
1	2.1011.105.2	6	nut m 8 p.1.25
2	0.311.1434.0	6	screw
3	0.311.1432.3	6	rocker arm
4	0.311.1430.0	3	support
5	2.1410.004.1	6	circlip 16
6	2.1499.527.1	3	circlip
7	0.311.1423.0	12	conical valve cotter
8	0.311.1425.0	6	cap-washer
9	2.4019.539.1	6	spring
10	2.1011.106.2	6	nut m 10 p.1.5
11	2.1481.058.1	6	spring washer 10
12	2.0439.614.2	3	stud bolt
13	2.0439.615.2	3	stud bolt
14	0.311.1416.4	6	valve guide
15	2.1031.003.1	3	cap nut
16	2.1560.206.0	3	copper gasket
17	0.311.1440.0	3	cover
18	0.311.1454.0	18	gasket
19	2.0422.207.2	3	stud bolt m 8 p 1.25 x 30
20	0.311.1453.0	3	valve seat
21	0.311.1452.0	3	valve seat
22	0.311.1450.0	3	gasket
23	0.311.1421.0	3	exhaust valve Ø mm 9
24	0.311.1420.0	3	inlet valve Ø mm 9
25	0.311.1410.4	3	engine head

43500-5

Section: ENGINE
LUBRICATION

Fig.	P/n	QTY	Name
------	-----	-----	------

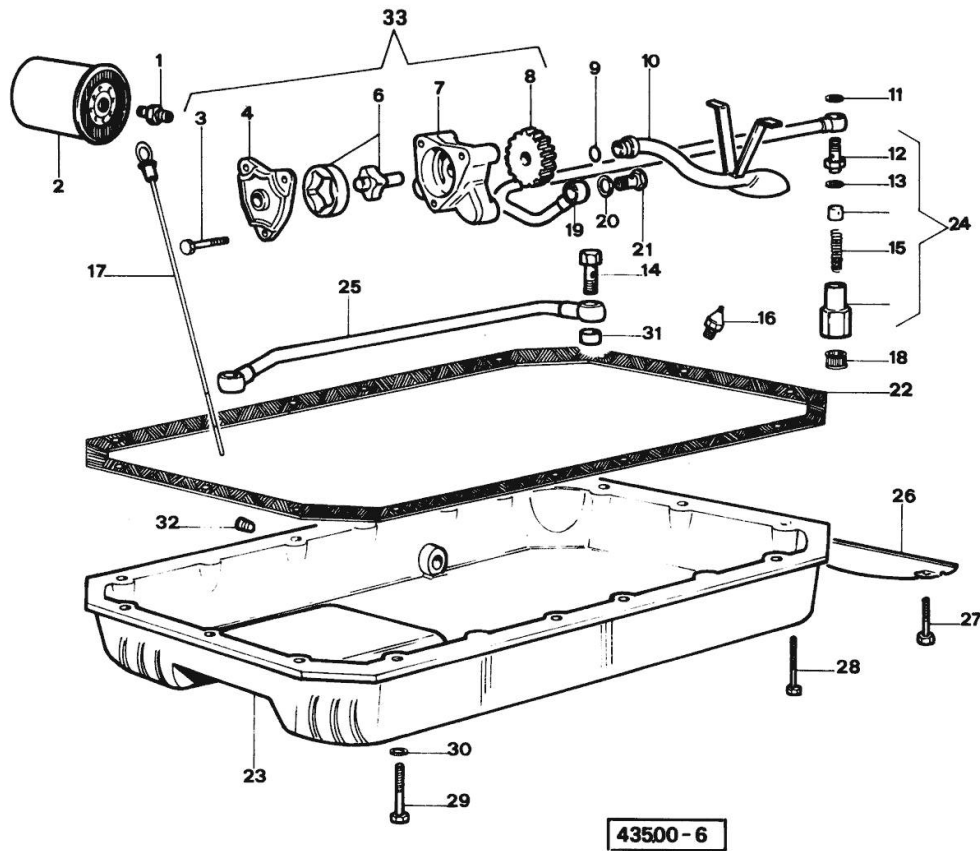
Notes:
[R 503]

1	2.3319.508.2	1	pipe fitting
2	2.4419.300.0	1	filter
3	2.0112.223.2	3	screw m 8 p.1.25x70
4	0.311.1526.0	1	small cover
6	0.311.1525.4	1	rotor
7	0.311.1520.0	1	pump casing
8	0.311.1521.0	1	gear
9	2.1539.503.0	1	special oil seal 17.86x2.62
10	0.311.1543.2	1	tube
11	2.1560.014.0	4	washer 18.2 x 24
12	2.3319.500.2	1	valve body
13	2.1560.016.0	1	gasket 20.2 x 26
14	2.3339.507.2	2	pipe fitting
15	2.4019.541.1	1	spring
16	2.7099.570.0	1	pressure switch
17	0.311.1513.2	1	dipstick
18	2.1579.643.0	1	special bushing
19	0.311.1531.2	1	tube
20	2.1560.018.0	2	gasket 22.2 x 29
21	2.3330.007.2	1	pipe union m 22 x 1.5
22	0.311.1554.0	1	gasket
23	0.311.1510.0	1	oil sump
24	0.311.1550.4	1	valve
25	0.311.1552.2	1	tube
			64677 <=
25	0.311.1552.2/10	1	tube
			=> 64678
26	0.311.1553.0	1	shield
27	2.0112.207.2	1	screw m 8 p 1.25 x 20
28	2.0112.222.2	1	screw m 8 p.1.25x65
29	2.0112.209.2	12	screw m 8 p 1.25 x 25
30	2.1481.057.1	7	washer 8
31	2.1579.608.0	2	spacer
32	2.3199.505.0	1	plug m 22 x 1.5
33	0.311.1520.4	1	oil pump

Buy Now



Our support email:

ebooklibonline@outlook.com